

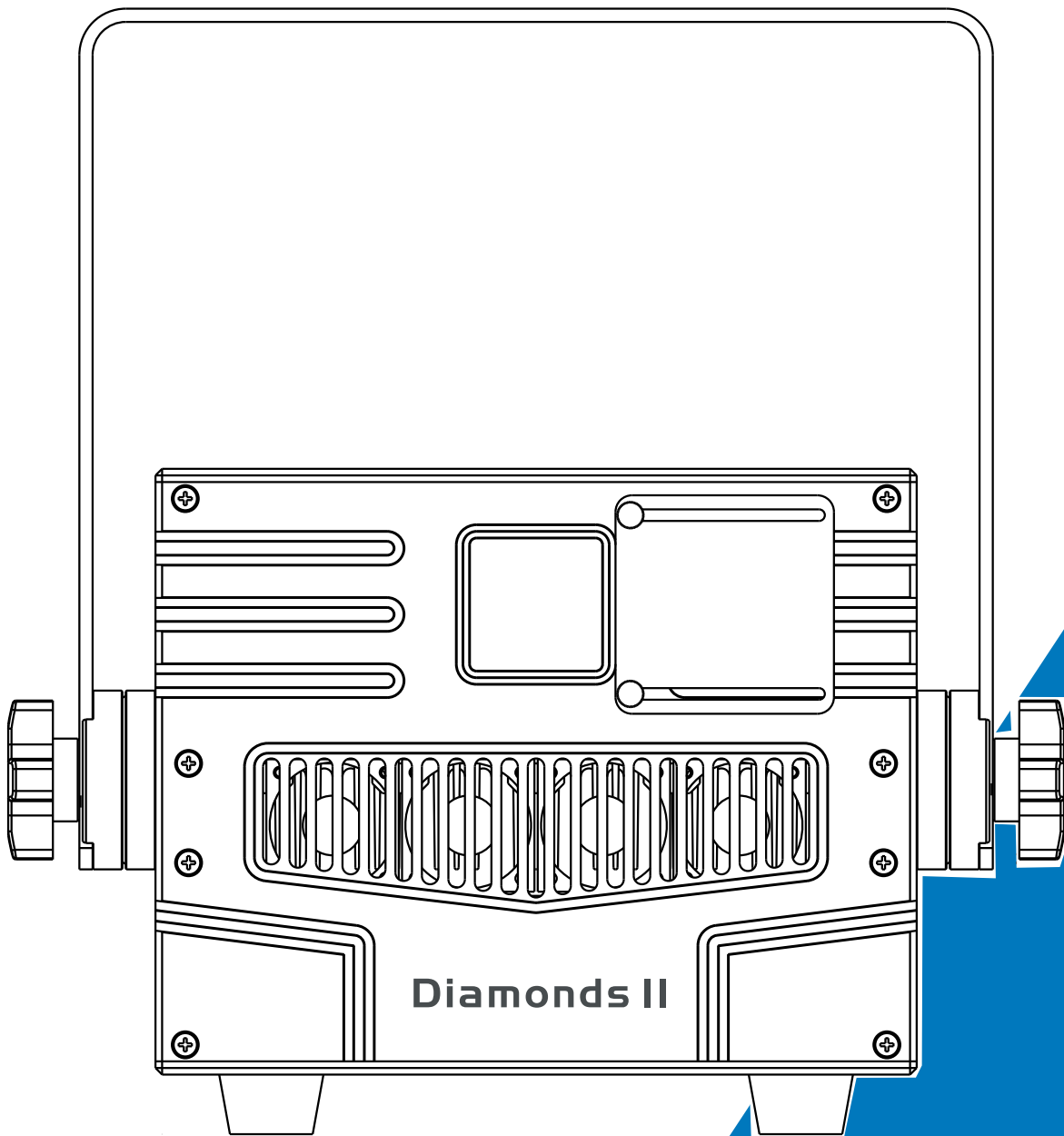

# Diamonds II



**User Manual**

Please read the instruction carefully before use

## CONTENTS

1. Safety Instructions .....	2
2. Technical Specifications.....	4
3. Control Panel .....	5
4. How To Set The Unit.....	6
5. How to Control the Unit.....	10
6. Control By Universal DMX Controller.....	11
6.1 DMX512 Connection .....	11
6.2 Address Setting .....	12
6.3 DMX512 Configuration.....	13
7. Troubleshooting .....	21
8. Fixture Cleaning .....	21

## 1. Safety Instructions



Please read the instruction carefully which includes important information about the installation, usage and maintenance.

### WARNING

**CAUTION - CLASS IV  
LASER RADIATION WHEN OPEN  
AVOID DIRECT EYE EXPOSURE**

Please keep this User Guide for future consultation. If you sell the unit to another user, be sure that they also receive this instruction booklet.

Please keep this User Guide for future consultation. If you sell the unit to another user, be sure that they also receive this instruction manual.

### Important:

**Damages caused by the disregard of this user manual are not subject to warranty.**

**The dealer will not accept liability for any resulting defects or problems.**

- Unpack and check carefully that there is no transportation damage before using the unit.
- This product is for indoor use only.
- DO install and operate by qualified operator.
- DO NOT allow children to operate the fixture.
- Use safety chain when fixing the unit. Handle the unit by carrying its base instead of head only.
- The unit must be installed in a location with adequate ventilation, at least 50cm from adjacent surfaces.
- Be sure that no ventilation slots are blocked, otherwise the unit will be overheated.

- Before operating, ensure that the voltage and frequency of power supply match the power requirements of the unit.
- It's important to ground the yellow/green conductor to earth in order to avoid electric shock.
- Minimum ambient temperature TA: 0°C. Maximum ambient temperature TA: 40°C.
- DO NOT connect the device to any dimmer pack.
- Make sure there are no flammable materials close to the unit while operating to avoid fire hazard.
- Examine the power wires carefully; replace them immediately if there is any damage.
- Unit's surface temperature may reach up to 65°C. DO NOT touch the housing bare-handed during its operation.
- Avoid any inflammable liquids, water or metal objects entering the unit. Once it happens, cut off the mains power immediately.
- DO NOT operate in dirty or dusty environment, do clean fixtures regularly.
- DO NOT touch any wire during operation as there might be a hazard of electric shock.
- Avoid power wires together twist other cables.
- The minimum distance between light output and the illuminated surface must be more than 0.5 meters.
- In the event of serious operating problem, stop using the unit immediately.
- Never turn on and off the unit time after time.
- The housing, the lenses, or the ultraviolet filter must be replaced if they are visibly damaged.

- DO NOT open the unit as there are no user serviceable parts inside.
- Never try to repair the unit by yourself. Repairs carried out by unskilled people can lead to damage or malfunction. Please contact the nearest authorized technical assistance center if needed.
- Disconnect the mains power if the fixture is has not been used for a long time.
- DO use the original packing materials before transporting it again.
- DO NOT look directly at the light while the bulb is on.
- DO NOT start on the unit without bulb enclosure or when housing is damaged.

**Installation:**

The fixture should be mounted via its Omega Quick Release Clamp bracket. Always ensure that the unit is firmly fixed to avoid vibration and slipping while operating and make sure that the structure to which you are attaching the unit is secure and is able to support a weight of 10 times of the fixtures weight. Always use a safety cable that can hold 12 times of the weight of the fixture when installing.

The equipment must be installed by professionals. It must be installed in a place where is out of the reach of people and no one can pass by or under

## **2. Technical Specifications**

**Power Voltage:**

100-240V~ 50/60Hz

**Power Consumption:**

185W

**Light Source:**

10W RGB

**Beam Angle:**

30°

**Dimmer/Shutter:**

Smooth dimming from 0-100%; outstanding strobe effect with variable speed

**Control:**

DMX Channel:: 27 / 52 CH

Control Mode: Voice CONTROL/SELF-WALKING/DMX512/Master/Slave/ILDA

**Construction:**

Display: OLED

Data In/Out: 3-pin (5-pin XLR is optional)

Power In/Out: Power Connector in/out

Protection Rating: IP20

**Features:**

Results: equipped with 50K Vibration Mirror, provide beam and a variety of built-in laser patterns and animation effects

For Pangolin, Phoenix, Mamba and other laser light show software

Suitable for clubs, bars, nightclubs, TV stations, advertising promotion and other places

The chassis adopts dustproof design, follows the classic double-layer design, the enclosure of the chassis is better, can effectively insulate the lampblack of the bar  
Lightweight, easy to transport and hanging lights, high brightness, color unity.

尺寸/重量:

9.1"x12.6"x7.2", 28lbs

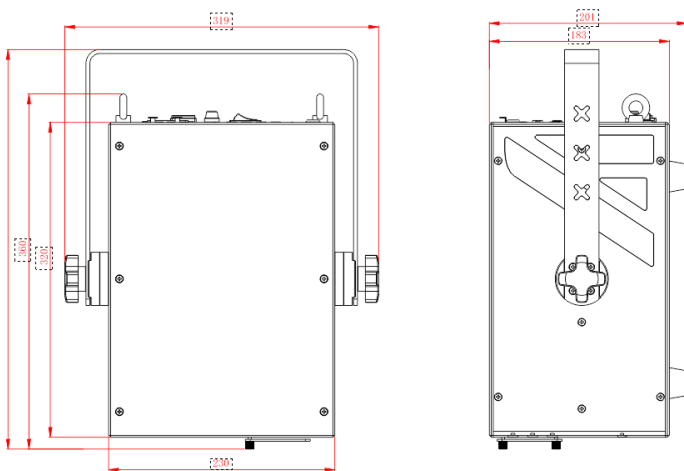

### 3. Control Panel

POWERCON Version:

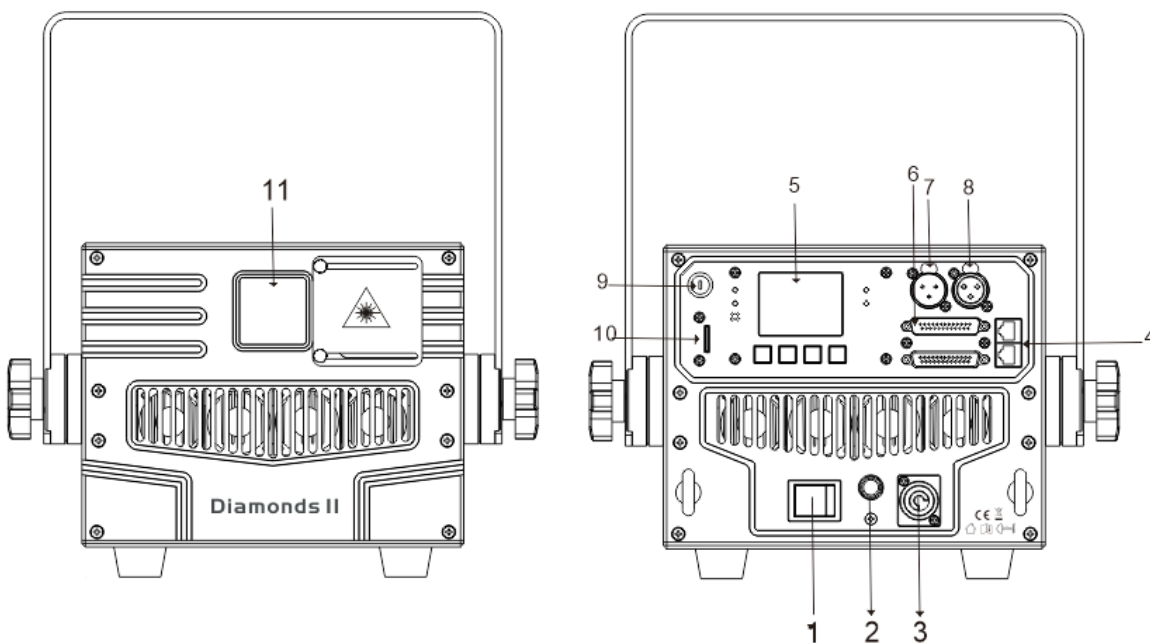

1. **POWER SWITCH:** Turn Power On/off
2. **KNOB**
3. **Power Input (POWERCON version) :** connect power supply
- 4: **EASY ILDA**
5. **Screen:** Liquid Crystal Display
6. **Ilda interface**
7. **DMX INPUT:** For DMX512 connections, use a 3-core XLR signal line to connect the lamp to the DMX console, and enter DMX signal (optional)
8. **DMX output:** For DMX512 connections, use 3-core XLR signal lines to connect to the next machine (optional 5-core)
9. **Key Switch:** to set to RUN, the lamp will light up

## 4. How To Set The Unit

### 4.1 Main Function

Turn on the unit, press the MENU button into menu mode, and press the UP/DOWN button until the required function is shown on the monitor. Select the function by the ENTER button. Use the UP/DOWN button to choose the submenu, press the ENTER button to store and automatically return to the last menu. Press the MENU button or let the unit idle One Minute to exit menu mode.

- **TFT screen menu list as following**

	First menu	Secondary menu
DMX address	1 - 512	
Auto in-play	Fast Beat ON/OFF	
	Medium Beat ON/OFF	
	Slow Beat ON/OFF	
	Animation ON/OFF	
Music in-play	Fast Beat ON/OFF	
	Medium Beat ON/OFF	
	Slow Beat ON/OFF	



	Animation ON/OFF		
SD card Mode	Repeat ON/OFF	ONE / FILE / ALL	
	Music ON/OFF		
	Directory 1/8		
	File 1/48		
Test Mode	Image 1-3		
System Setting	Channel Setting 27CH / 52CH		
	Master / Slave ON/OFF		
	Scan-safety ON/OFF		
	EASY ILDA ON/OFF		
	Language CH/EN		
	Sound Sense 0-100		
	About	Channel Num	
		Operational Mode	
		DMX Address	
		Case temperature	
		Running Time	
Hardware version			
Software version			
Reset Setting			
Master Setting	Color RGB/G		
	Scan 15-50K		
	Brightness 0-255		
	Design	R Fade 0-255	
		G Fade 0-255	
		B Fade 0-255	
		Zoom 0-255	
		X Size 0-255	
		Y Size 0-255	
	Invert X ON/OFF		
	Invert Y ON/OFF		

## **DMX Addresses**

To select **DMX Addresses**, Press the **ENTER** button to confirm that the current mode will be displayed on the display, use the **UP/DOWN** button to select the DMX entry address, use the Knob to find the start address (001-512) , and then press the Knob to confirm and set. Go back to the main menu and select exit

## **Auto in-play**

To select **Auto in-play**, Press the **ENTER** button to confirm that the current mode is displayed on the screen, using the **UP/DOWN** button to select: **Fast Beat, Medium Beat, Slow Beat, Animation**, press the Knob to confirm and set. Go back to the main menu and select exit.

## **Music in-play**

To select **Music in-play**, Press the **ENTER** button to confirm that the current mode is displayed on the screen, using the **UP/DOWN** button to select: **Fast Beat, Medium Beat, Slow Beat, Animation**, press the Knob to confirm and set. Go back to the main menu and select exit.

## **SD card mode**

To select SD card mode , Press the **ENTER** button to confirm that the current mode will be displayed on the display, using the **UP/DOWN** button to select: **Repeat, Music, Directory, File** , press the button to confirm. Go to the SD file, select the file or folder you want to play, and press the button to confirm. Go back to the main menu and select exit.

1. The native system can read the **SD card** 8 already fixed folder, each folder can read 48 pattern file, pattern file format (.ILD) format file. The **UP/DOWN** button allows you to select a pattern file. If the looping is set to ON, the entire SD folder will be looped. (single file name selection is invalid.) If you want to select a single file name, you need to return the looping to OFF. With the **UP/ DOWN** button, you can choose the way to trigger the pattern file to play, ON is the voice trigger, OFF is the automatic trigger.

2. Insert the SD card into the light fixture and use the UP, DOWN button to select the SD card mode, or use the console to press the channel to play the SD card file, or use the console to find the files you need and select the SD card mode on the light fixture (ONE is a single FILE looping, FILE is a single folder ALL files looping, ALL is the entire SD card looping) .

3. The content of SD card can be played by console

(1). In SD card, you can find 8 folders, folder naming rule as following

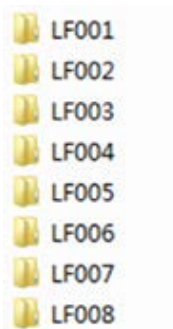

(2). Add file (.ild) to folder, (note:file name could be number or letter, and should not exceed 32 letters) as following

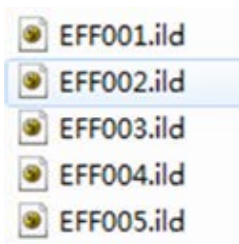

(3). Folder and content play sequence as following

The files in folder will be played in the order in which the files are copied to the SD card. That is, the first copied, first play. If you want to change the play sequence, you can copy them in the sequence you want. The folders will be played according to the fixed folder number(From LF001 ...LF008) in the sequence of copying.

The name of the SD card folder	
File folder	(EN)
LF001	Animals
LF002	Abstracts1
LF003	Abstracts2
LF004	Music+Dancers
LF005	People+Characters
LF006	Themes
LF007	Logos+Text
LF008	Shows

### Test Mode

To select **Test Mode**, Press the **ENTER** button to confirm that the current mode is displayed on the display, selected using the **UP/DOWN** button, press the Knob to confirm and test the pattern 1-6. Go back to the main menu and select exit.

### System Setting

To select **System Setting**, Press the **ENTER** button to confirm that the current mode will be displayed on the display, use the **UP/DOWN** button to select:

**Channel Settings, Master,slave settings, EASY ILDA, Language,Sound**

**Sense,About,Reset Setting**, press the Knob to confirm. Go back to the main menu and select exit.

## **Master Setting**

To select **Master Setting**, Press the **ENTER** button to confirm that the current mode will be displayed on the display, use the **UP/DOWN** button to select: **Color ,Scan Brightness,Design , Invert X ,Invert Y**, press the Knob to confirm. Go back to the main menu and select exit.

## ***RDM FUNCTIONS***

Select the MANUFACTURER menu to display the manufacturer of the fixture.

Select the SOFTWARE VERSION menu and the program version number of the fixture will be displayed.

Select the DMX START ADDRESS menu to change the DMX 512 address (001-512).

Select the DEVICE MODEL DESCRIPTION menu to display the model of the fixture.

Select the DEVICE LABEL menu to change the model of the fixture.

Select the DMX PERSONALITY menu to set the channel mode of the fixture (27/52channel).

Select the DMX PERSONALITY DESCRIPTION menu to display the current channel mode of the fixture.

Select the DEVICE HOURS menu to display the running time of the fixture.

Select the RESET DEVICE menu, the WARM RESET/COLD RESET option will be displayed. When WARM RESET is selected, the fixture will start a warm reset, and exit when COLD RESET is selected.

## **5.How to Control the Unit**

### **1. By ILDA;**

Connect the unit to the computer with ILDA wire and control the software by computer laser;

Priority to control the unit: ILDA > DMX > Sound active > Auto play

### **2. By universal DMX controller;**

Set the DMX address, the unit will be ready to receive DMX signal.

### **3. Sound active;**

The unit will run show by the sound active.

### **4. Auto play;**

The unit will auto play when no signal.

## 6. Control By Universal DMX Controller

### 6.1 DMX512 Connection

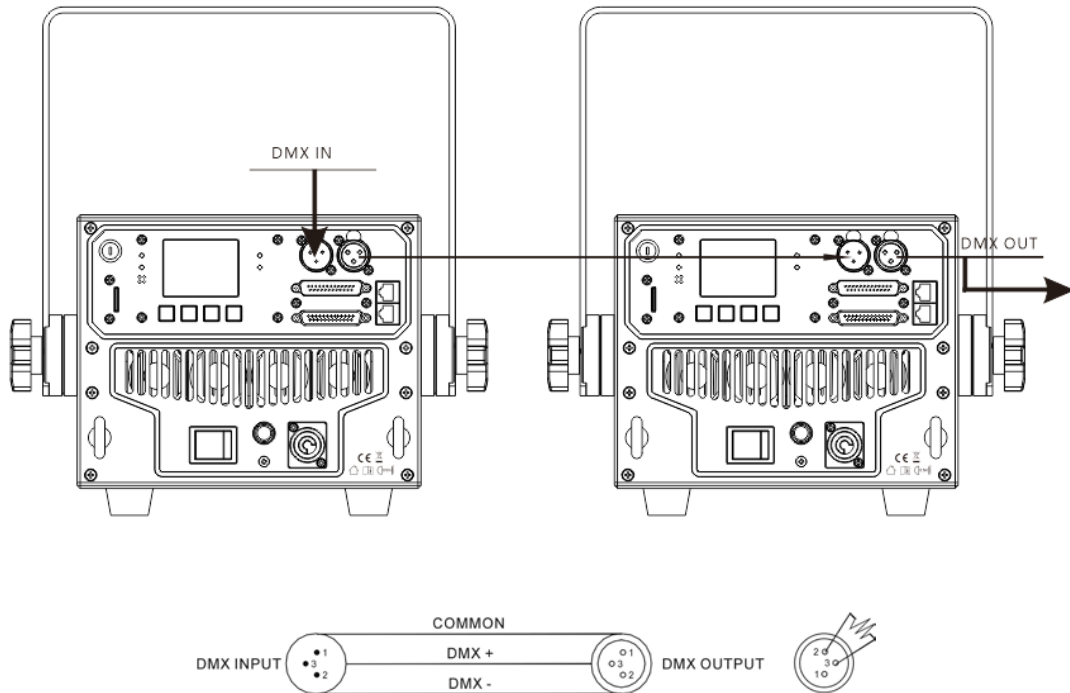

1. At last unit, the DMX cable has to be terminated with a terminator. Solder a 120-ohm 1/4W resistor between pin 2(DMX-) and pin 3(DMX+) into a 3-pin XLR-plug and plug it in the DMX-output of the last unit.
  2. Connect the unit together in a “daisy chain” by XLR plug cable from the output of the unit to the input of the next unit. The cable cannot be branched or split to a “Y” cable. DMX 512 is a very high-speed signal. Inadequate or damaged cables, soldered joints or corroded connectors can easily distort the signal and shut down the system.
3. The DMX output and input connectors are pass-through to maintain the DMX circuit, when one of the units’ power is disconnected.
4. Each lighting unit needs to have a DMX address to receive the data by the controller. The address number is between 1-508.
5. The end of the DMX 512 system should be terminated to reduce signal errors.
6. 3 pin XLR connectors are more popular than 5 pins XLR.
  - 3 pin XLR: Pin 1: GND, Pin 2: Negative signal (-), Pin 3: Positive signal (+)
  - 5 pin XLR: Pin 1: GND, Pin 2: Negative signal (-), Pin 3: Positive signal (+), Pin4, Pin5 not used.

## 6.2 Address Setting

If you use a universal DMX controller to control the units, you have to set DMX address from 1 to 512 so that the units can receive DMX signal.

Press the MENU button to enter menu mode, select DMX Settings, press the ENTER button to confirm, use the UP/DOWN button to select DMX Address, press the ENTER button to confirm, the present address will blink on the display, use the UP/DOWN button to adjust the address from 001 to 512, press the ENTER button to store. Press the MENU button back to the last menu or let the unit idle one minute to exit menu mode.

Please refer to the following diagram to address your DMX512 channel for the first 4 units.

Channel mode	Unit 1 Address	Unit 2 Address	Unit 3 Address	Unit 4 Address
27 channels	1	28	55	82
52 channels	1	53	105	157

## 6.3 DMX512 Configuration

Please refer to the following channel Diagram to control the lights note: 1. If you disconnect the DMX signal, the lamp will remain in the state it was before the signal was disconnected, unless you reset it. 2. In the "function" channel, hold the channel value for about 25 seconds and the lamp will run the corresponding function. This lamp IPLAY mode has 2 kinds of channel modes 27CH and 52CH (channel mode can be selected from system setting → channel number setting) , SD mode is not affected by channel number setting, SD PLAY only has 1 channel mode, the mode and explanation are as follows:

## ● DMX-512 channel

CH1=32-63, CH2 - CH27 or CH2 - CH52 valid

CH1=64-127, CH2, CH6 valid

Channel	Parameter	Value	Parameter description	
CH1	IPLAY mode	0 ~ 31	Black	
		32 ~ 63	Manual play	
		64 ~ 95	Auto play	
		96 ~ 127	Music play	
	SD mode	128 ~ 159	Manual play	
		160 ~ 191	Auto play	
		192 ~ 223	Music play (one file)	
		224 ~ 255	Music play (all files loop)	
CH2	Dimmer	0 ~ 255	Fade 0% .... 100%	
CH3	CH28	Red	0 ~ 255	Fade 0% .... 100%
CH4	CH29	Green	0 ~ 255	Fade 0% .... 100%
CH5	CH30	Blue	0 ~ 255	Fade 0% .... 100%
CH6	CH31	List	0 ~ 255	Each 32 value be 1 list , total 8 list
		Macro		Each 64 value be 1 macro , total 4 macro
CH7	CH32	Cue	0 ~ 15	Black
			16 ~ 255	Each 12 value be 1 cue, total 20 cues
CH8	CH33	X position	0 ~ 255	Left .... right ( 128 center )
CH9	CH34	X fine	0 ~ 255	X fine position
CH10	CH35	Y position	0 ~ 255	Down ....up ( 128 center )
CH11	CH36	Y fine	0 ~ 255	Y fine position
CH12	CH37	Rotation	0 ~ 255	Clockwise rotation (0°-360°)
CH13	CH38	Fine rotation	0 ~ 255	Fine rotation
CH14	CH39	Zoom	0 ~ 255	100%...0%
CH15	CH40	X flip	0 ~ 255	Left...right
CH16	CH41	Y flip	0 ~ 255	Down ... up
CH17	CH42	Color	0 ~ 7	Default
			8 ~ 15	White
			16 ~ 23	Red
			24 ~ 31	Yellow
			32 ~ 39	Green
			40 ~ 47	Cyan
			48 ~ 55	Blue
			56 ~ 63	Purple
			64 ~ 127	Each 8 value be 1 color effect , total 8
			128 ~ 143	Macro 1
			144 ~ 159	Macro 2
			160 ~ 175	Macro 3
			176 ~ 191	Macro 4
			192 ~ 207	Macro 5



			208 ~ 223	Macro 6
			224 ~ 239	Macro 7
			240 ~ 255	Macro 8
CH18	CH43	Write in	0 ~ 255	Visible point 100%-0
CH19	CH44	Deformation	0 ~ 15	Invalid
			16~31	Macro 1 ( valid for 14CH 25CH )
			32~47	Macro 2 ( valid for 14CH 25CH )
			48~63	Macro 3 ( valid for 14CH 25CH )
			64~79	Macro 4 ( valid for 14CH 25CH )
			80~95	Macro 5 ( valid for 14CH 25CH )
			96~111	Macro 6 ( valid for 14CH 25CH )
			112~127	Macro 7 ( valid for 14CH 25CH )
			128~143	Macro 8 ( valid for 14CH 25CH )
			144~159	Macro 9 ( valid for 14CH 25CH )
			160~175	Macro 10 ( valid for 14CH 25CH )
			176~191	Macro 11 ( valid for 14CH 25CH )
			192~207	Macro 12 ( valid for 14CH 25CH )
			208~223	Macro 13 ( valid for 14CH 25CH )
			224 ~ 255	Default
CH20	CH45	Wave	0	Invalid
			1 ~ 39	Macro 1
			40 ~ 79	Macro 2
			80 ~ 119	Macro 3
			120 ~ 159	Macro 4
			160 ~ 199	Macro 5
			200 ~ 255	Macro 6
CH21	CH46	Write in	0	Invalid
			1 ~ 42	Macro 1
			43 ~ 84	Macro 2

			85 ~ 126	Macro 3
		Strobe	127 ~ 255	Slow... fast
CH22	CH47	X position	0	Invalid
			1 ~ 32	Macro 1
			33 ~ 64	Macro 2
			65 ~ 96	Macro 3
			97 ~ 128	Macro 4
			129 ~ 160	Macro 5
			161 ~ 192	Macro 6
			193 ~ 224	Macro 7
			225 ~ 255	Macro 8
CH23	CH48	Y position	0	Invalid
			1 ~ 32	Macro 1
			33 ~ 64	Macro 2
			65 ~ 96	Macro 3
			97 ~ 128	Macro 4
			129 ~ 160	Macro 5
			161 ~ 192	Macro 6
			193 ~ 224	Macro 7
			225 ~ 255	Macro 8
CH24	CH49	Z rotation	0	Invalid
			1 ~ 32	Macro 1
			33 ~ 64	Macro 2
			65 ~ 96	Macro 3
			97 ~ 128	Macro 4
			129 ~ 160	Macro 5
			161 ~ 192	Macro 6
			193 ~ 224	Macro 7
			225 ~ 255	Macro 8
CH25	CH50	Zoom	0	Invalid
			1 ~ 32	Macro 1

			33 ~ 64	Macro 2
			65 ~ 96	Macro 3
			97 ~ 128	Macro 4
			129 ~ 160	Macro 5
			161 ~ 192	Macro 6
			193 ~ 224	Macro 7
			225 ~ 255	Macro 8
CH26	CH51	X flip	0	Invalid
			1 ~ 32	Macro 1
			33 ~ 64	Macro 2
			65 ~ 96	Macro 3
			97 ~ 128	Macro 4
			129 ~ 160	Macro 5
			161 ~ 192	Macro 6
			193 ~ 224	Macro 7
			225 ~ 255	Macro 8
CH27	CH52	Y flip	0	Invalid
			1 ~ 32	Macro 1
			33 ~ 64	Macro 2
			65 ~ 96	Macro 3
			97 ~ 128	Macro 4
			129 ~ 160	Macro 5
			161 ~ 192	Macro 6
			193 ~ 224	Macro 7
			225 ~ 255	Macro 8

SD card 20CH

Channel	Parameter	Value	Parameter description
CH1	IPLAY mode	0 ~ 31	Black
		32 ~ 63	Manual play
		64 ~ 95	Auto play
		96 ~ 127	Music play
	SD mode	128 ~ 159	Manual play
		160 ~ 191	Auto play
		192 ~ 223	Music play (one file)
		224 ~ 255	Music play (all files loop)
CH2	Dimmer	0 ~ 255	Brightness 0% .... 100%
CH3	Red	0 ~ 255	Brightness 0% .... 100%
CH4	Green	0 ~ 255	Brightness 0% .... 100%
CH5	Blue	0 ~ 255	Brightness 0% .... 100%
CH6	List	0 ~ 255	Each 32 value be 1 list , total 8 list
	Macro		each 10 value be 1 macro , total 25 macro
CH7	Cue	0 ~ 15	Black
		16 ~ 255	Each 12 value be 1 cue,total 20 cues
CH8	X position	0 ~ 255	Left .... right ( 128 center )
CH9	X fine	0 ~ 255	X fine position
CH10	Y position	0 ~ 255	Up ....down ( 128 center )
CH11	Y fine	0 ~ 255	Y fine position
CH12	Rotation	0 ~ 255	Clockwise rotation (0°-360°)
CH13	Fine rotation	0 ~ 255	Fine rotation
CH14	Zoom	0 ~ 255	100%....0%
CH15	X flip	0 ~ 255	Left...right
CH16	Y flip	0 ~ 255	Down ... up

CH17	Color	0 ~ 31	Default
		32 ~ 63	White
		64 ~ 95	Red
		96 ~ 127	Yellow
		128 ~ 159	Green
		160 ~ 191	Cyan
		192 ~ 223	Blue
		224 ~ 255	Purple
CH18	Write in	0 ~ 255	Visible point 100%-0
CH19	Speed	0 ~ 15	Default
		16~31	Pause
		32~255	25% - 200%
CH20	Scan rate	0 ~ 31	Default
		32 ~ 223	6k - 29k
		224 ~ 255	30k

## **7. Troubleshooting**

Following are a few common problems that may occur during operation. Here are some suggestions for easy troubleshooting:

### **A. The unit does not work, no light and the fan does not work**

1. Check the connect power.
2. Measure the mains voltage on the main connector.
3. Check the power on LED to see if it can be light up or not.

### **B. Not responding to DMX controller**

1. DMX LED should be on. If not, check DMX connectors, cables to see if they are linked properly.
2. If the DMX LED is on and no response to the channel, check the address settings and DMX polarity.
3. If you have intermittent DMX signal problems, check the pins on connectors or on PCB of the unit or the previous one.
4. Try to use another DMX controller.
5. Check to see if the DMX cables run near or run alongside to high voltage cables that may cause damage or interference to DMX interface circuit.

### **C. One of the channels is not working well**

1. The stepper motor might be damaged or the cable connected to the PCB is broken.
2. The motor's drive IC on the PCB might be out of condition.

## **8. Fixture Cleaning**

The cleaning of internal and external optical lenses and/or mirrors must be carried out periodically to optimize light output. Cleaning frequency depends on the environment in which the fixture operates: damp, smoky or particularly dirty surrounding can cause greater accumulation of dirt on the unit's optics.

- Clean with soft cloth and use normal glass to clean liquid.
- Always dry the parts carefully.
- lean the external optics at least every 20 days.



**Innovation, Quality, Performance**