

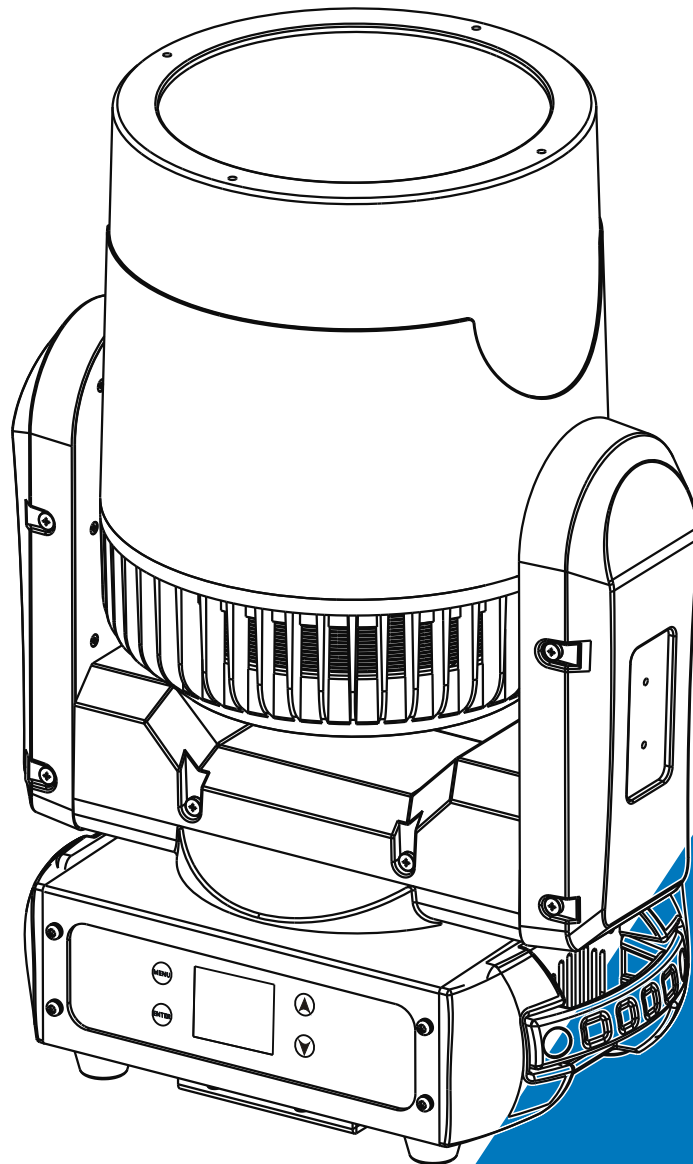

NEBULA



User Manual

Please read the instruction carefully before use

CONTENTS

1. Safety Instructions.....	2
2. Technical Specifications.....	3
3. Control Panel.....	4
4. How to set the fixture	5
4.1 Menu	5
5. Control by DMX 512 controller	12
5.1 DMX Connection	12
5.2 DMX Address Setting.....	12
5.3 DMX Configuration.....	13
6. Troubleshooting	15
7. Fixture Cleaning	16

1. Safety Instructions



Please read carefully the instruction, which includes important information about the installation, usage and maintenance.

WARNING

- Please keep this User Guide for future consultation. If you sell the unit to another user, be sure that they also receive this instruction booklet.
- Unpack and check carefully there is no transportation damage before using the unit.
- Before operating, ensure that the voltage and frequency of power supply match the power requirements of the unit.
- It's important to ground the yellow/green conductor to earth in order to avoid electric shock.
- The unit is for indoor use only. Use only in a dry location.
- The unit must be installed in a location with adequate ventilation, at least 50cm from adjacent surfaces. Be sure that no ventilation slots are blocked.
- Disconnect main power before replacement or servicing.
- Make sure there are no flammable materials close to the unit while operating as it is fire hazard.
- Use safety cable when fixes this unit. DO NOT handle the unit by taking its head only, but always by taking its base.
- Maximum ambient temperature is T_a : 0-40°C.
- Unit surface temperature may reach up to 60°C. DO NOT touch the housing bare-hand during its operation. Turn off the power and allow about 15 minutes for the unit to cool down before replacing or serving.
- In the event of serious operating problem, stop using the unit immediately. Never try to repair the unit by yourself. Repairs carried out by unskilled people can lead to damage or malfunction. Please contact the nearest authorized technical assistance center. Always use the same type spare parts.
- DO NOT touch any wire during operation as high voltage might be causing electric shock.

Warning:

- To prevent or reduce the risk of electrical shock or fire, do not expose the unit to rain or

moisture.

- DO NOT open the unit within five minutes after switching off.
- The housing, the lenses, or the ultraviolet filter must be replaced if they are visibly damaged.

Caution:

There are no user serviceable parts inside the unit. DO NOT open the housing or attempt any repairs yourself. In the unlikely event your unit may require service, please contact your nearest dealer.

Installation:

The unit is fully operational in three different mounting positions, hanging upside-down from a ceiling or set on a flat level surface. To avoid internal damage to the unit, never mount the unit on its side as illustrated above. Be sure this fixture is kept at least 0.5m away from any flammable materials (decoration etc.). Always use and install the supplied safety cable as a safety measure to prevent accidental damage and/or injury in the event the clamp fails.

1. Bolt each clamp to the Omega holder with screw and lock nut through the hole in the holder.
2. Faster the omega holders on the bottom of the base by inserting quick-lock fasteners into the holes of the base and tighten fully clockwise.
3. Hang the fixture to the support through clamp and faster the screws, Faster the safety cable through the bottom of the base and over the support.

2. Technical Specifications

- DMX Channels: 7/9/10 channels mode
- LCD display for easy navigation
- Perfect for stage, theatre, TV studio, rental and discotheques
- **Voltage:** 100-240V~ 50/60Hz
- **Power consumption:** 255W
- **LED:** 200W COB

- **Color temperature** CM-250Z WW/3000K CM-250Z CW /5700K
- **Beam Angle:** 10-40 Degree
- **Dimension/ Weight:**
310x218x451.5mm, 10.3Kg
12.2"x8.6"x17.8" in, 22.7lbs

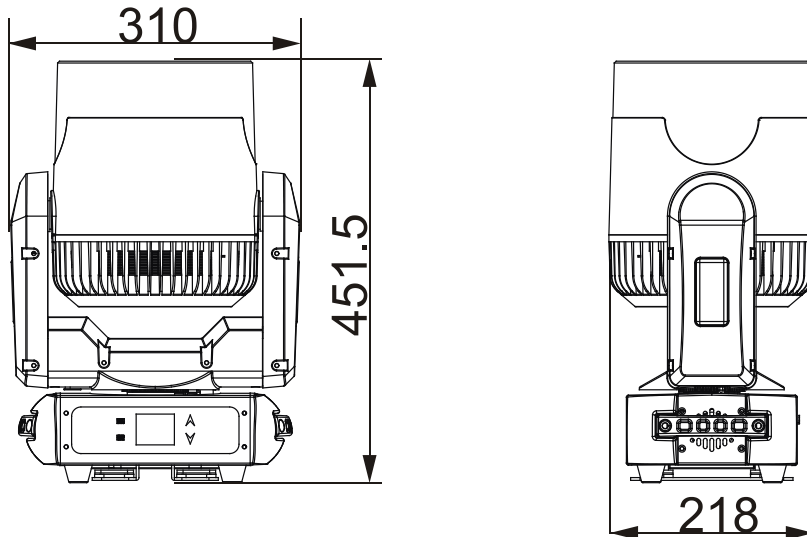

3. Control Panel

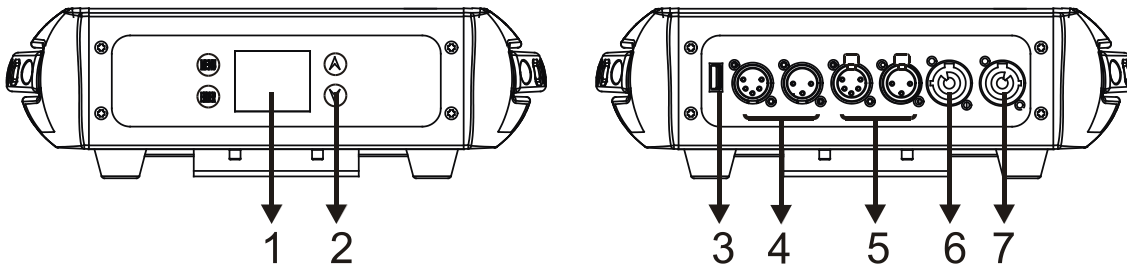

1. Monitor (Batter Back-up display):

2. Button:

MENU	To enter into move backward or leave the menu
▲ UP	To go backward to move up in the menu
▼ DOWN	To go to move down in the menu
ENTER	To perform the desired functions

3. Firmware Upgrade:

Procedures for updating fixture.

4/5. FMX input /output:

DMX 512 link, use 5 XLR cable to link the unit and DMX controller.

6. Power In:

To connect to the mains supply

7. Power Out:

To connect to the next lamp supply

4. How to set the fixture

4.1 Menu

To select any of the given functions, press the **MENU** button up to when the required one is showing on the display. Select the function by the **ENTER** button and the display will blink. Use the **DOWN** and **UP** button to change the mode. Once the required mode has been selected, press the **ENTER** button to setup, to go back to the functions without any change press the **MENU** button again. Hold and press the **MENU** button about one second or wait for one minute to exit the menu mode.

The main functions are showing below:

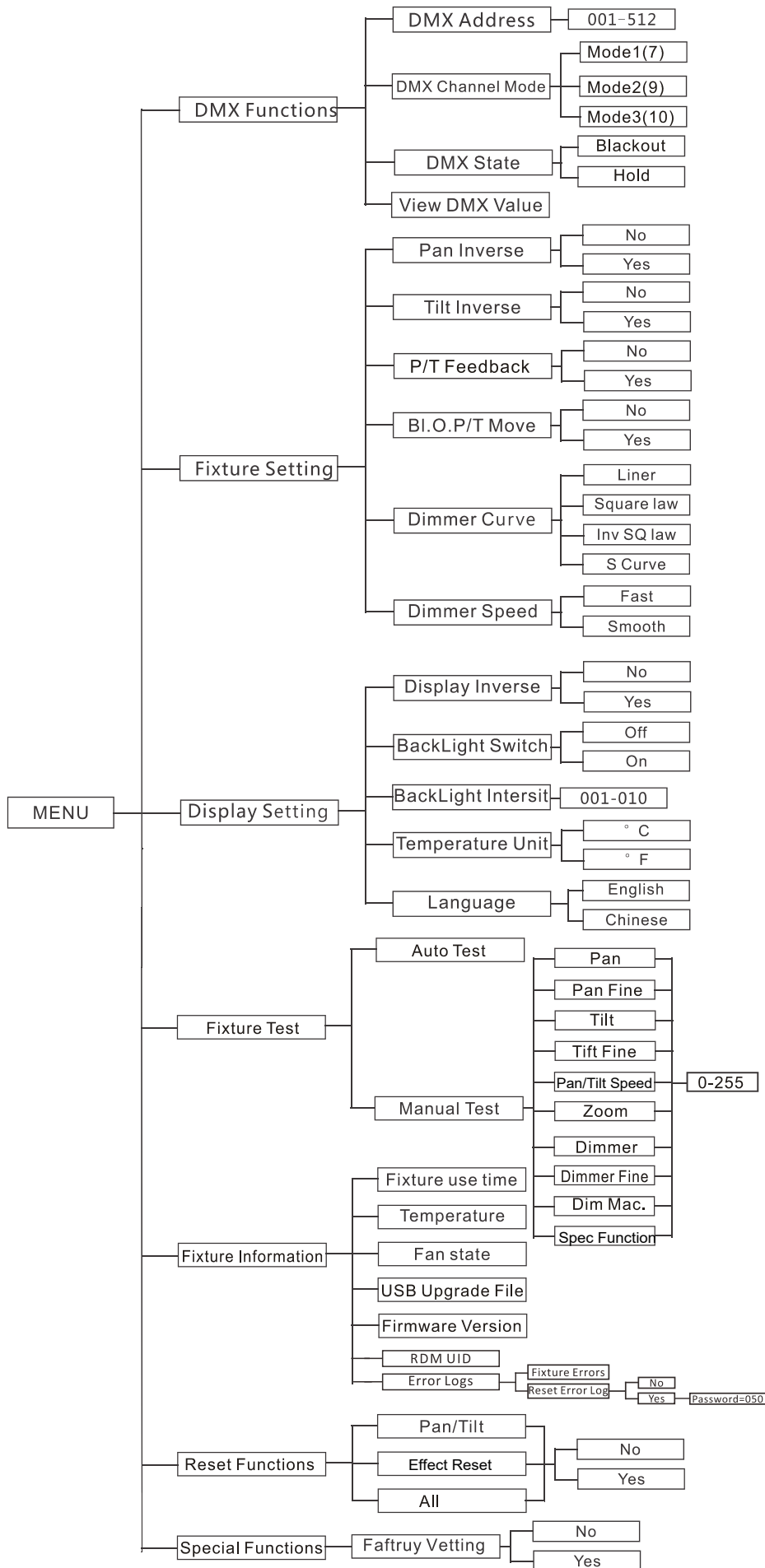

DMX Functions

Enter MENU mode, select **DMX Functions**, press the **ENTER** button to confirm, use the **UP/DOWN** button to select **DMX Address**, **DMX Channel Mode**, **View DMX Value** or **WDMX Setting**.

DMX Address

To select **DMX Address**, press the **ENTER** button to show the **DMX ADDRESS** on the display. Use the **UP/DOWN** button to adjust the address from **001** to **512**, press the **ENTER** button to setup. Press the **MENU** button back to the last menu or let the unit idle one minute to exit menu mode.

DMX Channel Mode

To select **DMX Channel Mode**, press the **ENTER** button to show the **DMX CHANNEL MODE** on the display. Use the **UP/DOWN** button to select **Mode1 (7)**, **Mode2 (9)** or **Mode (10)**, and press the **ENTER** button to setup. Press the **MENU** button back to the last menu or let the unit idle one minute to exit menu mode.

View DMX Value

To select **View DMX Value**, press the **ENTER** button to show the **VIEW DMX VALUE** on the display. Use the **UP/DOWN** button to view the DMX channel values. Press the **MENU** button back to the last menu or let the unit idle one minute to exit menu mode.

Fixture Setting

Enter MENU mode, select **Fixture Setting**, press the **ENTER** button to confirm, use the **UP/DOWN** button to select **Pan Inverse**, **Tile Inverse**, **BL.O. P/T Moving**, **Dimmer Curve** or **Dimmer Speed**.

Pan Inverse

To select **Pan Inverse**, press the **ENTER** button to show the **PAN INVERSE** on the display. Use the **UP/DOWN** button to select **No** (normal) or **Yes** (pan inverse), press the **ENTER** button to setup. Press the **MENU** button back to the last menu or let the unit idle one minute to exit menu mode.

Tilt Inverse

To select **Tilt Inverse**, press the **ENTER** button to show the **TILT INVERSE** on the display. Use the **UP/DOWN** button to select **No** (normal) or **Yes** (tilt inverse), press the **ENTER** button to setup.

Press the **MENU** button back to the last menu or let the unit idle one minute to exit menu mode.

P/T Feedback

To select **P/T Feedback**, press the **ENTER** button to show the **P/T Feedback** on the display. Use the **UP/DOWN** button to select **No** (normal) or **Yes** (tilt inverse), press the **ENTER** button to setup. Press the **MENU** button back to the last menu or let the unit idle one minute to exit menu mode.

BL.O. P/T Move

To select **BL.O. P/T Move**, press the **ENTER** button to show the **BLACKOUT WHILE PAN/TILT MOVING** on the display, use the **UP/DOWN** button to select **No** (normal while pan/tilt moving) or **Yes** (blackout while pan/tilt moving), press the **ENTER** button to setup. Press the **MENU** button back to the last menu or let the unit idle one minute to exit menu mode.

Dimmer Curve

To select **Dimmer Curve**, press the **ENTER** button to show the **DIMMER CURVE** on the display, use the **UP/DOWN** button to select **Linear**, **Square Law**, **Inverse Squ.** or **S-curve**. Once selected, press the **ENTER** button to store. Press the **MENU** button back to the last menu or let the unit idle one minute to exit menu mode.

Dimmer Modes:

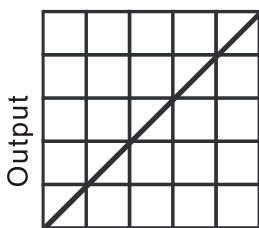

DMX%
(Optically Linear)

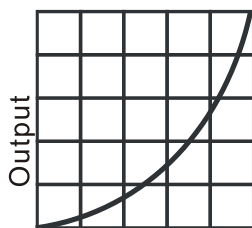

DMX%
(Square Law)

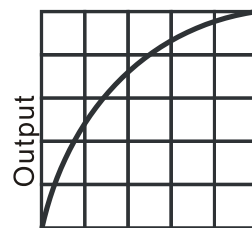

DMX%
(Inverse Square Law)

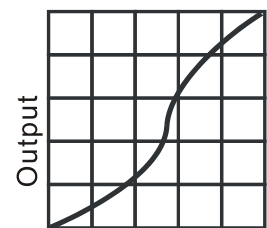

DMX%
(S-Curve)

Linear: The increase in light intensity appears to be linear as DMX value is increased.

Square Law: Light intensity control is finer at low levels and coarser at high levels.

Inverse Square Law: Light intensity control is coarser at low levels and finer at high levels.

S-cure: Light intensity control is finer at low levels and high levels and coarser at medium levels.

Dimmer Speed

To select **Dimmer Speed**, press the **ENTER** button to show the **DIMMER SPEED** on the display. Use the **UP/DOWN** button to select **Fast** or **Smooth**. Once selected, press the **ENTER** button to

setup. Press the **MENU** button back to the last menu or let the unit idle one minute to exit menu mode.

Display Setting

Enter **MENU** mode, select **Display Setting**, press the **ENTER** button to confirm, use the **UP/DOWN** button to select **Display Inverse**, **Backlight Switch**, **Backlight Intensity**, **Temperature unit** or **Language**.

Display Inverse

To select **Display Inverse**, press the **ENTER** button to show the **DISPLAY INVERSE** on the display. Use the **UP/DOWN** button to select **No** (normal) or **Yes** (display inverse). Once selected, press the **ENTER** button to store. Press the **MENU** button back to the last menu or let the unit idle one minute to exit menu mode.

Backlight Switch

To select **Backlight Switch**, press the **ENTER** button to show the **BACKLIGHT AUTO OFF** on the display. Use the **UP/DOWN** button to select **No** (display always on) or **Yes** (display goes off one minute after exiting menu mode). Once selected, press the **ENTER** button to confirm and store. Press the **MENU** button back to the last menu or let the unit idle one minute to exit menu mode.

Backlight Intensity

To select **Backlight Intensity**, press the **ENTER** button to show the **BACKLIGHT INTENSITY** on the display. Use the **UP/DOWN** button to adjust the intensity from **1** (dark) to **10** (bright). Once selected, press the **ENTER** button to setup and store. Press the **MENU** button back to the last menu or let the unit idle one minute to exit menu mode.

Temperature Unit

To Select **Temperature Unit**, press the **ENTER** button to show the **TEMPERATURE UNIT** on the display. Use the **UP/DOWN** button to select **°C** or **°F**, press the **ENTER** button to store. Press the **MENU** button back to the last menu or let the unit idle one minute to exit menu mode.

Language

To select **Language**, press the **ENTER** button to show the **LANGUAGE** on the display. Use the **UP/DOWN** button to select **English** or **Chinese**, press the **ENTER** button to store. Press the **MENU**

button back to the last menu or let the unit idle one minute to exit menu mode.

Fixture Test

Enter **MENU** mode, select **Fixture Test**, press the **ENTER** button to confirm, use the **UP/DOWN** button to select **Auto Test** or **Manual Test**

Auto Test

To select **Auto Test**, press the **ENTER** button to show the **AUTO TEST** on the display. Press the **ENTER** button, the unit will run built-in programs to automatically test pan, tilt and zoom. Press the **MENU** button back to the last menu or exit menu mode after auto test.

Manual Test

To select **Manual Test**, press the **ENTER** button to show the **MANUAL TEST** on the display. Press the **ENTER** button, and then use the **UP/DOWN** button to select channel, and adjust the channel value. Once selected, press the **ENTER** button to setup, the fixture will run as the channel value indicates. Press the **MENU** button back to the last menu or exit menu mode let the unit idle one minute.

(All channels value will become 0 after exiting **Manual Test** menu)

Fixture Information

Enter **MENU** mode, select **Fixture Information**, press the **ENTER** button to confirm, use the **UP/DOWN** button to select **Fixture use time, Temperature, Fan state, USB Upgrade File , Firmware Version. RDM UID or Error Logs.**

Reset Function

To select **Reset Function**, press the **ENTER** button to confirm, use the **UP/DOWN** button to select **Pan/Tilt , Effect Reset or All .**

Pan/Tilt

To Select **Pan/Tilt**, press the **ENTER** button to show the **PAN/TILT** on the display. Use the **UP/DOWN** button to select **Yes** (the unit will run built-in program to reset pan and tilt to their home positions) or **No**, press the **ENTER** button to store. Press the **MENU** button to exit menu mode.

Effect Reset

Select **Effect Reset**, press the **ENTER** button to confirm, use the **UP/DOWN** button to select **No**(normal) or **Yes** (the unit will run built-in program to reset effect to their home positions), press the **ENTER** button to store. Press the **MENU** button to exit.

All

To select **All**, press the **ENTER** button to show the **ALL** on the display. Use the **UP/DOWN** button to select **Yes** (the unit will run built-in program to reset all motors to their home positions) or **No**, press **ENTER** button to store. Press **MENU** button to exit menu mode.

RDM UID

Select **RDM UID**, press the **ENTER** button to confirm, RDM UID will show on the display, press the **MENU** button back to exit.

Error Logs

Select **Error Logs**, press the **ENTER** button to confirm. Use the **UP/DOWN** button to select **Fixture Errors** or **Reset Error Log**, press the **ENTER** button to store. Select **Reset Error Log**, press the **ENTER** button to confirm. Use the **UP/DOWN** button to select **No** or **Yes**, press the **ENTER** button to store. Select **Yes**, press the **ENTER** button to confirm. Use the **UP/DOWN** button to set the password **050**, press the **ENTER** button to store. Press the **MENU** button back to the last menu or let the unit idle 30 seconds to exit menu mode.

Special Functions

Enter MENU mode, select **Special Functions**, press the **ENTER** button to confirm, use the **UP/DOWN** button to select **Factory Setting**.

Factory Setting

To select **Factory Setting**, press the **ENTER** button to show the **FACTORY SETTING** on the display. Press the **ENTER** button to confirm, use the **UP/DOWN** button to select **No** or **Yes** (the fixture will reset to factory settings and exit menu mode).

RDM	
DMX START	0-512
MANUFACTURER	ACME
DEVICE MODEL DESCRIPTION	CM-250Z
DMX PERSONALITY	7CH 9CH 10CH
DEVICE LABEL	CM-250Z
IDENTIFY DEVICE	Off/On
PAN INVERT	Off/On
TILT INVERT	Off/On
DEVICE HOURS	
SOFTWARE	
RESET DEVICE	Warm/Cold

5. Control by DMX 512 controller

5.1 DMX Connection

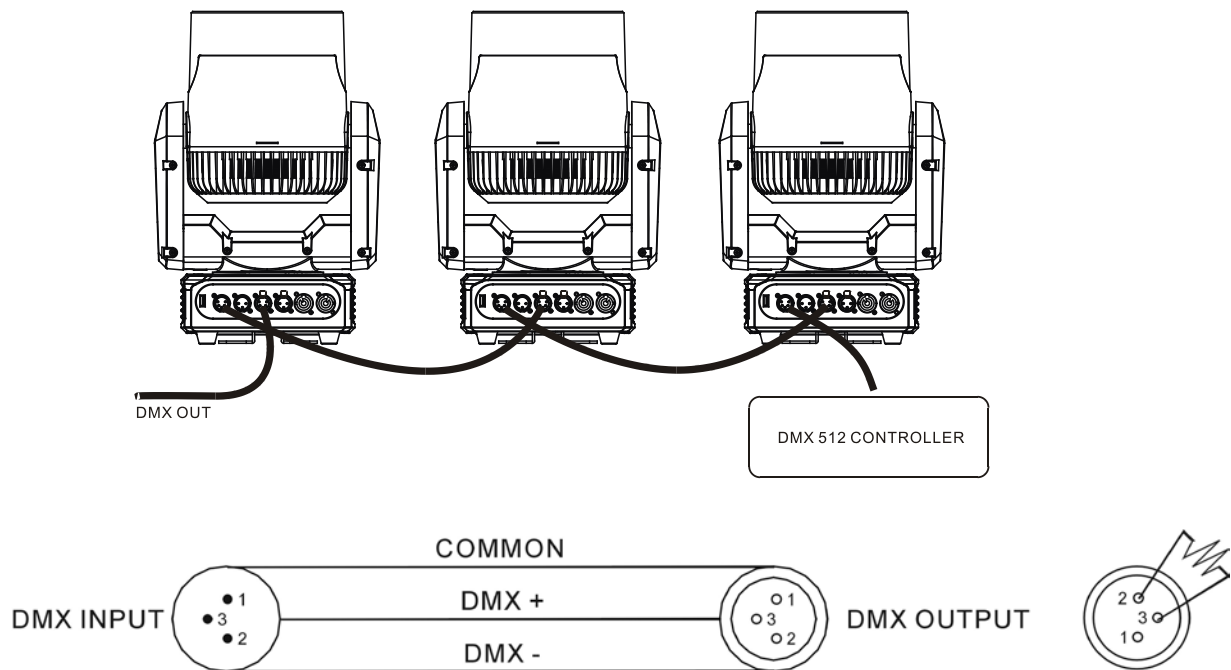

1. Connect the fixture together in a “daisy chain” by XLR plug cable from the output of the fixture to the input of the next fixture. The cable cannot be branched or split to a “Y” cable. Inadequate or damaged cables, soldered joints or corroded connectors can easily distort the signal and shut down the system
2. The DMX output and input connectors are pass-through to maintain the DMX circuit when one of the units’ power is disconnected.
3. At last fixture, the DMX cable has to be terminated with a terminator to reduce signal errors. Solder a 120-ohm 1/4W resistor between pin 2(DMX-) and pin 3(DMX+) into a 3-pin XLR-plug and plug it in the DMX-output of the last fixture.
4. Each lighting fixture needs to have an address set to receive the data sent by the controller. The address number is between 0-511 (usually 0 & 1 are equal to 1).
5. 3 pin XLR connectors are more popular than 5 pins XLR.
3 pin XLR: Pin 1: GND, Pin 2: Negative signal (-), Pin 3: Positive signal (+)

5.2 DMX Address Setting

By using a universal DMX controller to control the units, you have to set DMX address from 1 to 512 so that the units can receive DMX signal.

Press the **MENU** button up to when the **DMX Address** is showing on the display. Pressing **ENTER** button and the display will blink. Use **DOWN** and **UP** button to change the DMX512 address. Once the address has been selected, press and keep **ENTER** button pressed up to when the display stops blinking or storing automatically 8 seconds later. To go back to the functions without any change press the **MENU** button again. If you use please refer to the following diagram to address your DMX512 channel for the first 4 units:

Channel mode	Unit 1 Address	Unit 2 Address	Unit 3 Address	Unit 4 Address
7 channels	1	8	17	22
9 channels	1	10	19	28
10 channels	1	11	21	31

5.3 DMX Configuration

7Channel model

Channel	Value	Function
1	0-255	Pan 0°→ 540°
2	0-255	Tilt 0° →200 °
3	0-255	Pan/Tilt Speed
4	0-255	Zoom 40°→10°
5	0-255	Dimmer 0→100%
6	0-255	Dimmer Fine
7		Special Function
	0-69	Null
	70-79	Black out Pan Tilt Move Enable
	80-89	Black out Pan Tilt Move Disable
	90-139	Null
	140-149	Pan/tilt Reset
	150-169	Null
	170-179	Zoom Reset
	180-199	Null
	200-209	Reset All
	210-255	Null

9Channel model

Channel	Value	Function
1	0-255	Pan 0°→ 540°
2	0-255	Pan Fine
3	0-255	Tilt 0° →200 °
4	0-255	Tilt Fine
5	0-255	Pan/Tilt Speed
6	0-255	Zoom 40°→10°
7	0-255	Dimmer 0→100%
8	0-255	Dimmer Fine
9		Special Function
	0-69	Null
	70-79	Black out Pan Tilt Move Enable
	80-89	Black out Pan Tilt Move Disable
	90-139	Null
	140-149	Pan/tilt Reset
	150-169	Null
	170-179	Zoom Reset
	180-199	Null
	200-209	Reset All
	210-255	Null

10Channel model

Channel	Value	Function
1	0-255	Pan 0° → 540°
2	0-255	Pan Fine
3	0-255	Tilt 0° → 200°
4	0-255	Tilt Fine
5	0-255	Pan/Tilt Speed
6	0-255	Zoom 40° → 10°
7	0-255	Dimmer 0 → 100%
8	0-255	Dimmer Fine
9		Macro
	0-31	Close
	32-63	Open
	64-95	Strobe
	96-127	Open
	128-159	Fast to Slow
	160-191	Open
	192-223	Random Strobe
	224-255	Open
10		Special Function
	0-69	Null
	70-79	Black out Pan Tilt Move Enable
	80-89	Black out Pan Tilt Move Disable
	90-139	Null
	140-149	Pan/tilt Reset
	150-169	Null
	170-179	Zoom Reset
	180-199	Null
	200-209	Reset All
	210-255	Null

6. Troubleshooting

Following are a few common problems that may occur during operation. Here are some suggestions for easy troubleshooting:

A. The unit does not work, no light and the fan does not work

1. Check the connection of power and main fuse.
2. Measure the mains voltage on the main connector.
3. Check the power on LED.

B. Not responding to DMX controller

1. DMX LED should be on. If not, check DMX connectors, cables to see if link properly.

2. If the DMX LED is on and no response to the channel, check the address settings and DMX polarity.
3. If you have intermittent DMX signal problems, check the pins on connectors or on PCB of the unit or the previous one.
4. Try to use another DMX controller.
5. Check if the DMX cables run near or run alongside to high voltage cables that may cause damage or interference to DMX interface circuit.

C. One of the channels is not working well

1. The stepper motor might be damaged or the cable connected to the PCB is broken.
2. The motor's drive IC on the PCB might be out of condition.

7. Fixture Cleaning

The cleaning of internal and external optical lenses and/or mirrors must be carried out periodically to optimize light output. Cleaning frequency depends on the environment in which the fixture operates: damp, smoky or particularly dirty surrounding can cause greater accumulation of dirt on the unit's optics.

- Clean with soft cloth using normal glass cleaning fluid.
- Always dry the parts carefully.
- Clean the external optics at least every 30 days.

Declaration of Conformity

We declare that our products (lighting equipments) comply with the following specification and bears CE mark in accordance with the provision of the Electromagnetic Compatibility (EMC) Directive 89/336/EEC.

EN55103-1: 2009+A1:2012; EN55103-2: 2009;
EN61000-3-2: 2014; EN61000-3-3: 2013.

&

Harmonized Standard

EN 60598-1:2015; EN 60598-2-17:1989 + A2:1991;
EN 62471:2008; EN 62493: 2010
Safety of household and similar electrical appliances
Part 1: General requirements