

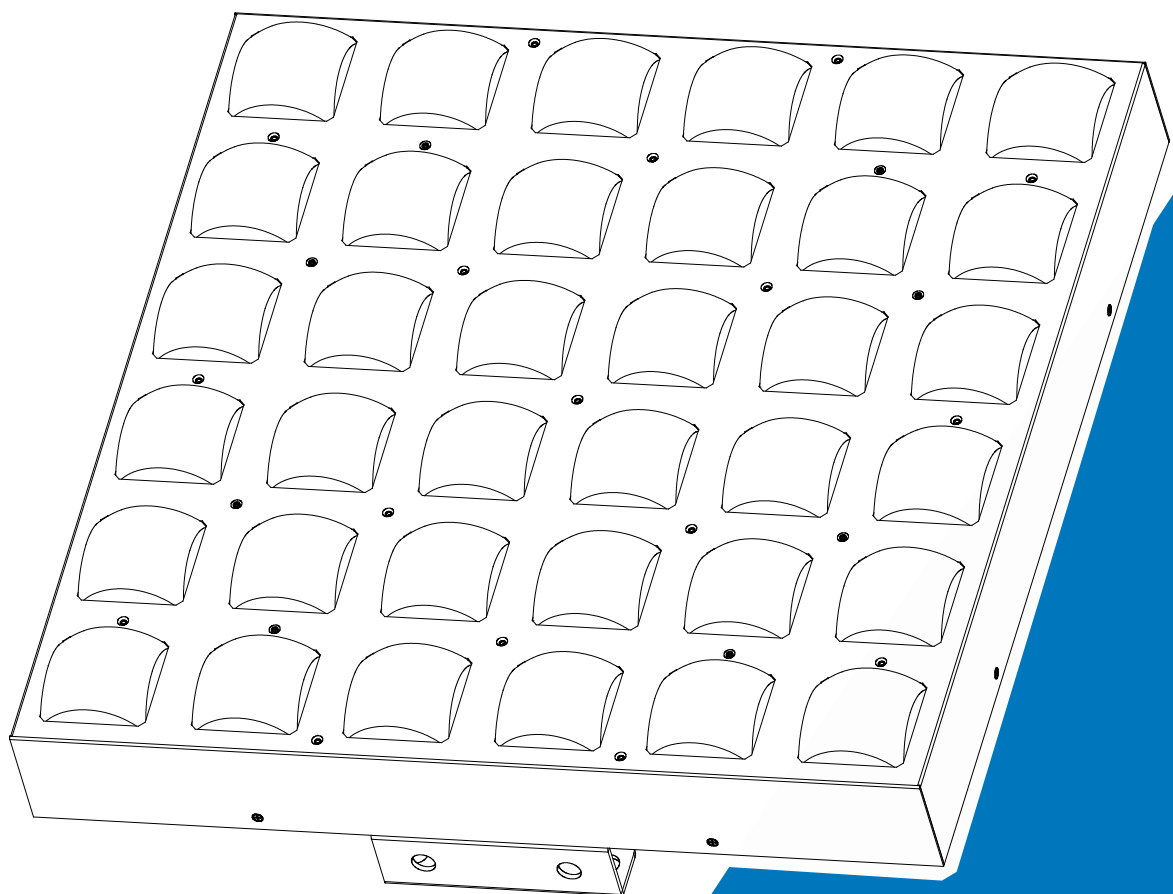

BRIGHT



User Manual

Please read the instruction carefully before use

CONTENTS

1. Safety Instructions	2
2. Technical Specifications	3
3. Control Panel	5
4. Installation	6
5. How To Set The Unit.....	7
5.1 Main Function.....	7
5.2 Home Position Adjustment	13
6. Control By Universal DMX Controller	15
6.1 DMX512 Connection	15
6.2 Address Setting	16
6.3 DMX512 Configuration.....	16
7. Error Information	32
8. Troubleshooting.....	33
9. Fixture Cleaning	33

1. Safety Instructions



Please read the instruction carefully which includes important information about the installation, usage and maintenance.

WARNING

Please keep this User Guide for future consultation. If you sell the unit to another user, be sure that they also receive this instruction manual.

Important:

Damages caused by the disregard of this user manual are not subject to warranty. The dealer will not accept liability for any resulting defects or problems.

- Unpack and check carefully to ensure that there is no transportation damage before using the unit.
- This product is for indoor use only. Use only in a dry location.
- DO install and operate by qualified operator.
- DO NOT allow children to operate the fixture.
- Use safety chain when fixing the unit. Handle the unit by carrying its base instead of head only.
- The unit must be installed in a location with adequate ventilation, at least 50cm from adjacent surfaces.
- Be sure that no ventilation slots is blocked, otherwise the unit will be overheated.
- Before operation, ensure that you are connecting this product to the proper voltage in accordance with the specifications in this manual or on the product's specification label.
- It's important to ground the yellow/green conductor to earth in order to avoid electric shock.
- Minimum ambient temperature TA: 0°C. Maximum ambient temperature TA: 40°C. Do not operate this product at a lower or higher temperature.
- DO NOT connect the device to any dimmer pack.
- Keep flammable materials away from the fixture while operating to avoid fire hazard.
- Make sure the power cord is not crimped or damaged; replace it immediately if damaged.
- Unit's surface temperature may reach up to 65°C. DO NOT touch the housing bare-handed during its operation.
- Avoid any flammable liquids, water or metal from entering the unit. Once it happens, cut off the mains power immediately.

- DO NOT operate in a dirty or dusty environment. DO clean the fixture regularly.
- DO NOT touch any wire during operation as there might be a hazard of electric shock.
- Avoid entanglement of the power cord with other wires.
- The minimum distance to objects/surface must be more than 0.5 meters.
- In the event of serious operating problem, stop using the unit immediately.
- Never turn on and off the unit time after time.
- The housing, the lenses, or the ultraviolet filter must be replaced if they are visibly damaged.
- DO NOT open the housing as there are no user serviceable parts inside.
- DO NOT attempt to operate this unit if it becomes damaged. DO NOT attempt any repairs yourself. Repairs carried out by unskilled people can lead to damage or malfunction. Please contact the nearest authorized technical assistance center if needed.
- Disconnect this product from its power source before servicing.
- DO use the original packaging if the device is to be transported.
- Avoid direct eye exposure to the light source while the product is on.
- DO NOT operate this product if you see damage on the housing, shields, or cables. Have the damaged parts replaced by an authorized technician at once.

2. Technical Specifications

Power Voltage:

180-240V~ 50/60Hz

Power Consumption:

155W

Light Source:

36x12W RGBW LED

Beam Angle:

2°

Dimmer/Shutter:

Smooth dimmer from 0-100%; outstanding variable speed strobe effect

Control:

DMX Channel: 147/17/11/4/44/144 Channels

Control Mode: DMX512, RDM

Firmware Upgrade via DMX link

Construction:

Display: OLED display

Data In/Out: 3-pin XLR (5-pin XLR is optional)

Power In/Out: Power Connector in/out

Protection Rating: IP20

Features:

Compact design, light in weight

Multiple units can be split-jointed horizontally with connecting board

LED can be controlled pixel by pixel, delivering versatile effects

Dimensions/ Weight:

500x152x500mm, 12.6kgs

19.7"x6"x19.7" in, 27.8lbs

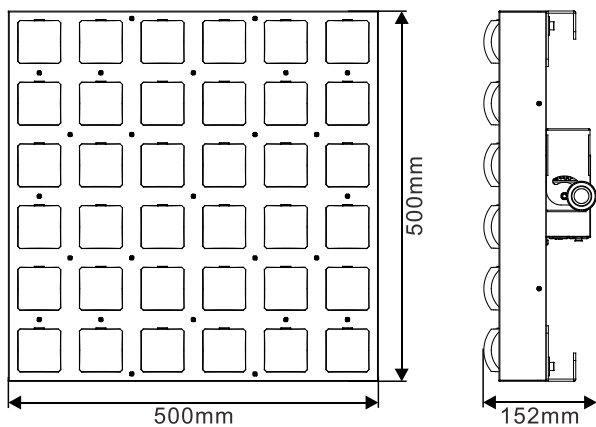

Photometric Diagram:

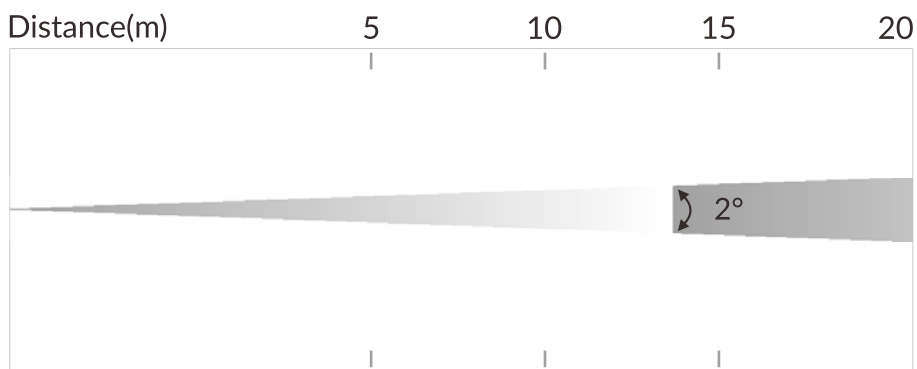

	5	10	15	20
2° R Lux	1544	386	172	96.5
2° G Lux	2064	516	229	129
2° B Lux	512	128	57	32
2° W Lux	5748	1437	639	359
Diameter(m)	0.17	0.35	1.05	1.4

3. Control Panel

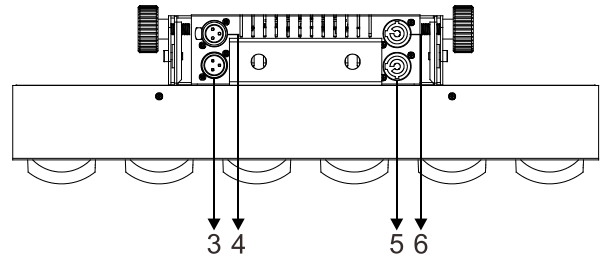
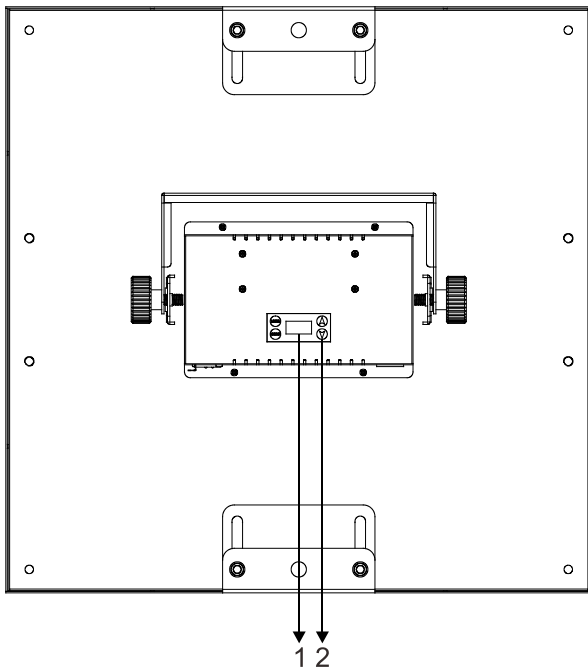

1. Display: To show the various menus and the selected function

2. Button:

MENU	To enter into move backward or leave the menu
▲ UP	To go backward to move up in the menu
▼ DOWN	To go forward to move down in the menu
ENTER	To perform the desired functions

3. DMX IN:

For DMX512 link, use 3-pin XLR cable to link the unit and DMX controller (5-pin XLR is optional)

4. DMX OUT:

For DMX512 link, use 3-pin XLR cable to link the next units (5-pin XLR is optional)

5. POWERCON IN: Connects to supply power

6. POWERCON OUT: Connects to the next fixture

4. Installation

The fixture should be fixed on the clamp. Always ensure that the unit is firmly fixed to avoid vibration and slipping off during operation. Ensure that the trussing or area of installation must be able to hold 10 times the weight without any deformation. Always install a safety cable that can hold at least 12 times the weight of the fixture when installing.

DO install and operate by qualified operator. It must be installed in a place where there is out of the reach of people.

1. Installation parallel to the plane

As shown in the figure, fix the clamp (B) on the hanger of the fixture by using screws and nuts (A) and lock the clamp (B) on the truss.

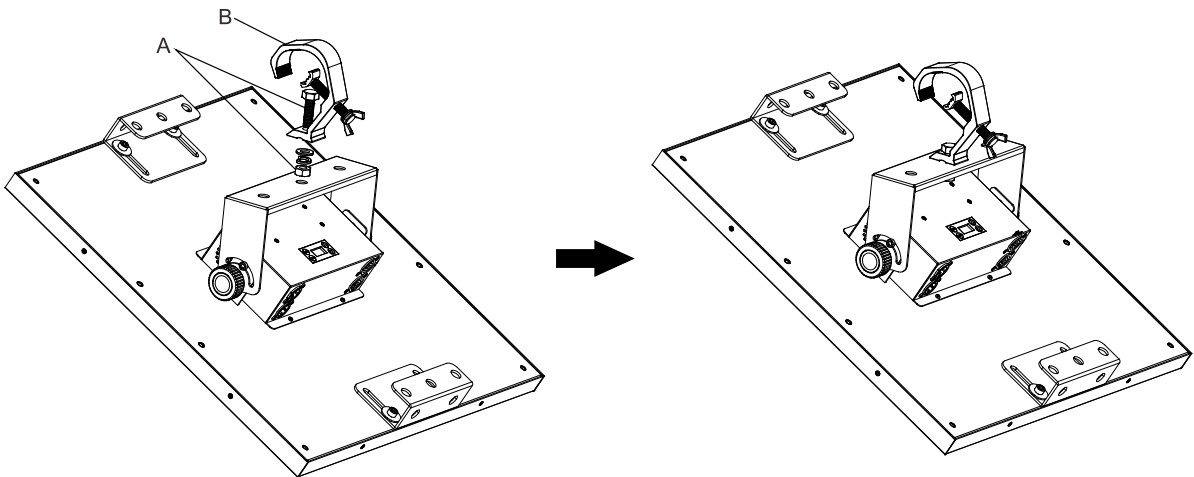

2. Installation vertical to the plane

As shown in the figure, fix the clamp (C) on the splicing plate (A) of the fixture by using screws and nuts (B) and lock the clamp (C) on the truss.

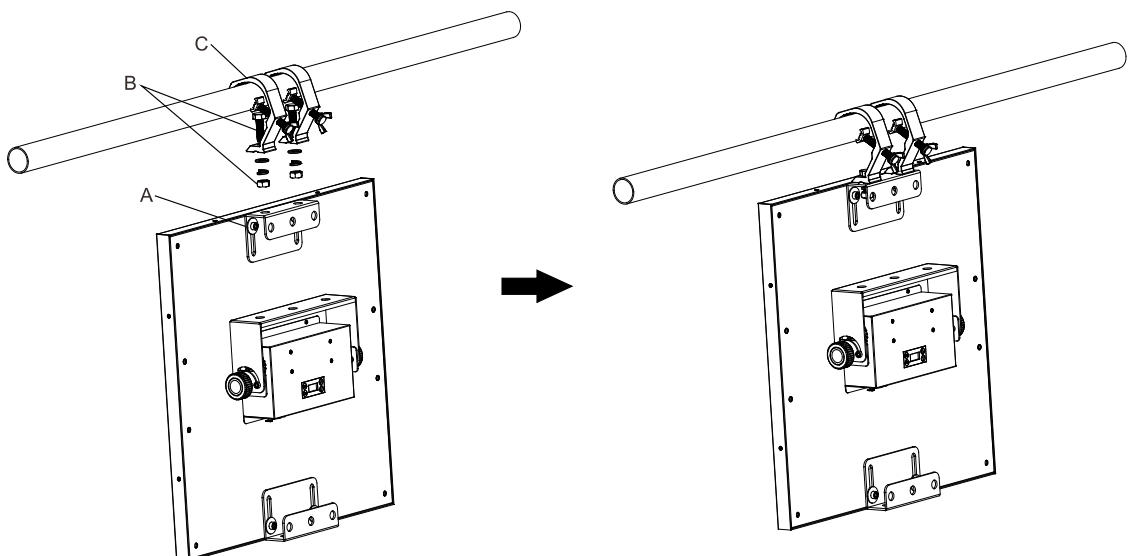

3. Multi-machine assembly

As shown in the figure, loosen the screws (A) of the splicing plate of the fixture. Then join the fixtures together in pairs and move the splicing plate, tighten the screws and fix them on the two fixtures; Fix the connecting plate (B) on the four corners of the fixtures by using screws and nuts so that the fixtures are spliced and fastened to each other; Fix the clamp (D) on the splicing plate of the fixture by using screws and nuts (C) and lock the clamp (D) on the truss.

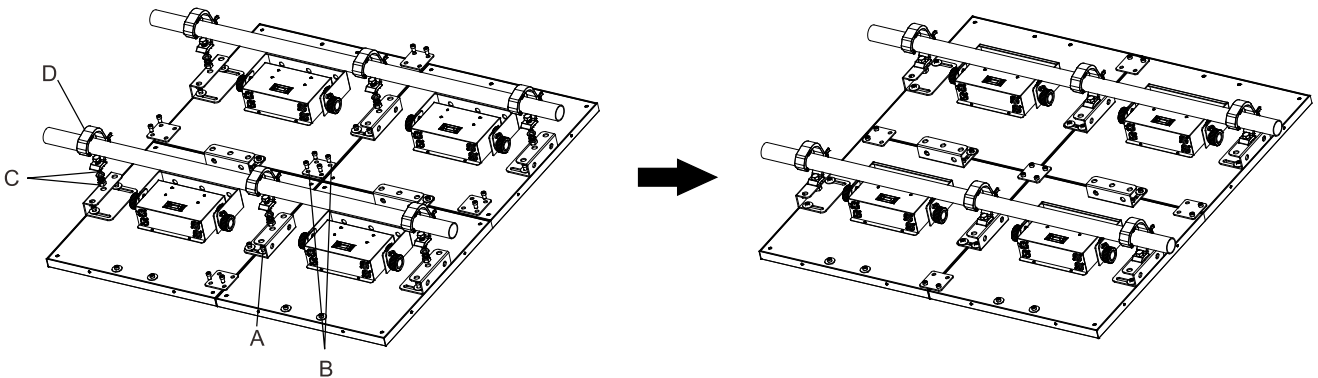

5. How To Set The Unit

5.1 Main Function

Turn on the unit, press the MENU button into menu mode, and press the UP/DOWN button until the required function is shown on the monitor. Select the function by pressing the ENTER button. Use the UP/DOWN button to choose the submenu, press the ENTER button to store and automatically return to the last menu. Press the MENU button or let the unit idle 30 seconds to exit menu mode.

The main functions are shown below:

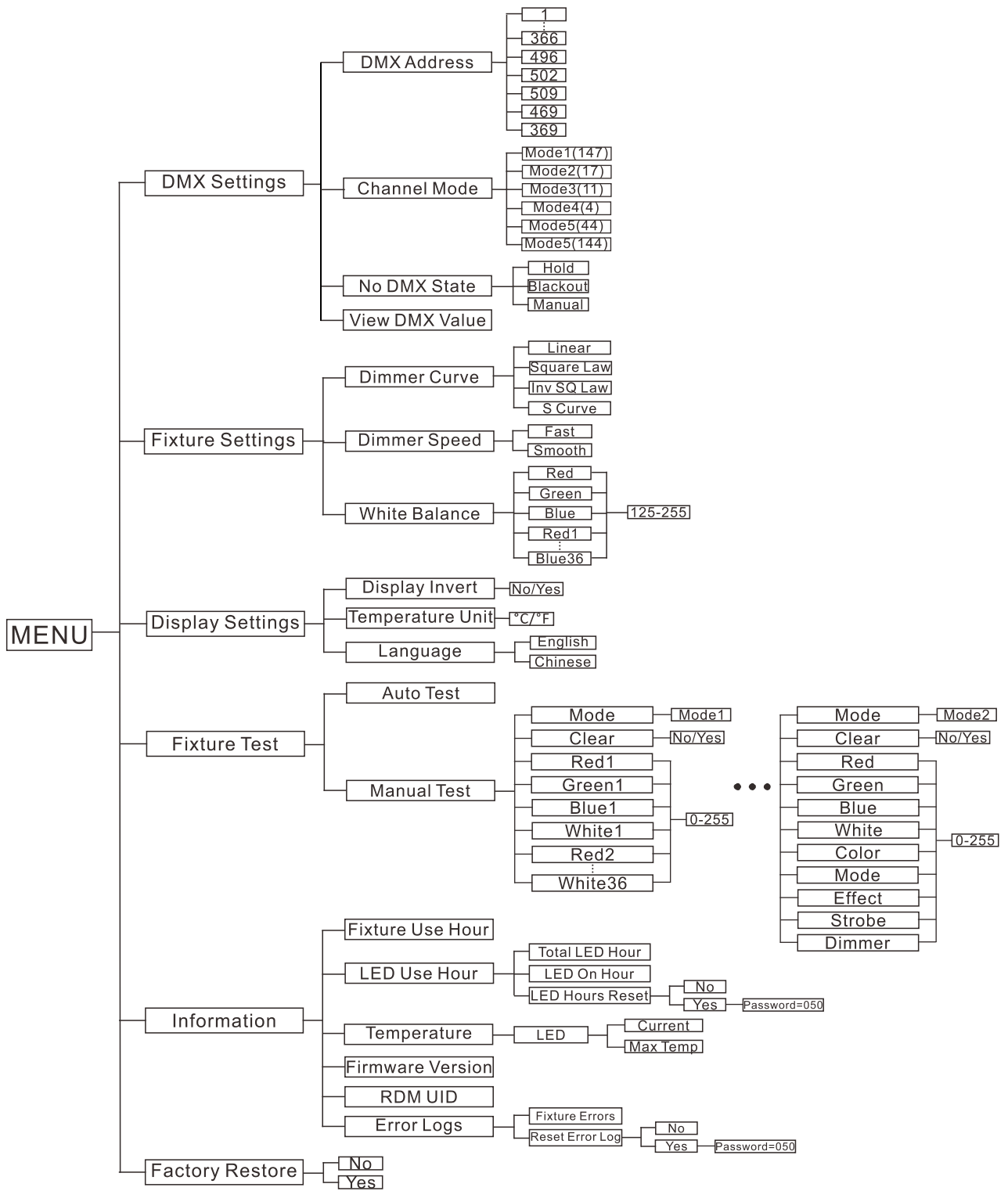

DMX Settings

To select **DMX Settings**, press the **ENTER** button to confirm, use the **UP/DOWN** button to select **DMX Address, Channel Mode, No DMX State** or **View DMX Value**.

DMX Address

To select **DMX Address**, press the **ENTER** button to confirm. Use the **UP/DOWN** button to adjust the address from **001** to **366/496/502/509/469/369**, press the **ENTER** button to store. Press the **MENU** button back to the last menu or let the unit idle 30 seconds to exit menu mode.

Channel Mode

To select **Channel Mode**, press the **ENTER** button to confirm. Use the **UP/DOWN** button to select **Mode1(147), Mode2(17), Mode3(11), Mode4(4), Mode5(44)** or **Mode6(144)**, press the **ENTER** button to store. Press the **MENU** button back to the last menu or let the unit idle 30 seconds to exit menu mode.

No DMX State

To select **No DMX State**, press the **ENTER** button to confirm. Use the **UP/DOWN** button to select **Hold**(fixture continues to obey the last command it received Via DMX if DMX signal stops), **Blackout**(fixture blacks out if DMX signal stops), or **Manual**(the fixture will automatically read the DMX value in the “Manual Test” menu for operation after selecting this mode), press the **ENTER** button to store. Press the **MENU** button back to the last menu or let the unit idle 30 seconds to exit menu mode.

View DMX Value

To select **View DMX Value**, press the **ENTER** button to confirm. Use the **UP/DOWN** button to view the DMX channel value. Press the **MENU** button back to the last menu or let the unit idle 30 seconds to exit menu mode.

Fixture Settings

To select **Fixture Settings**, press the **ENTER** button to confirm, use the **UP/DOWN** button to select **Dimmer Curve, Dimmer Speed** or **White Balance**.

Dimmer Curve

To select **Dimmer Curve**, press the **ENTER** button to confirm. Use the **DOWN/UP** button to select **Linear, Square Law, Inv SQ Law** or **S Curve**, press the **ENTER** button to store. Press the **MENU** button back to the last menu or let the unit idle 30 seconds to exit menu mode.

Dimmer Modes

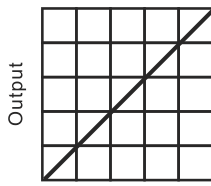

Optically Linear

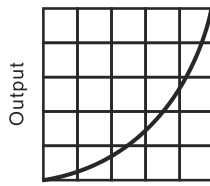

Square Law

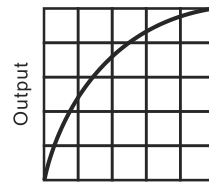

Inverse Square Law

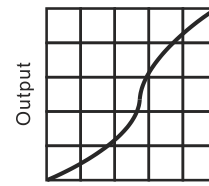

S-curve

Optically Linear: The increase in light intensity appears to be linear as DMX value is increased.

Square Law: Light intensity control is finer at low levels and coarser at high levels.

Inverse Square Law: Light intensity control is coarser at low levels and finer at high levels.

S-Curve: Light intensity control is finer at low levels and high levels and coarser at medium levels.

Dimmer Speed

To select **Dimmer Speed**, press the **ENTER** button to confirm. Use the **UP/DOWN** button to select **Fast** or **Smooth**, press the **ENTER** button to store. Press the **MENU** button back to the last menu or let the unit idle 30 seconds to exit menu mode.

White Balance

To select **White Balance**, press the **ENTER** button to confirm. Use the **UP/DOWN** button to select **Red, Green, Blue, Red1, Green1, Blue1.....** or **Red36, Green36, Blue36**, press the **ENTER** button to store. Press the **MENU** button back to the last menu or let the unit idle 30 seconds to exit menu mode.

Display Settings

To select **Display Settings**, press the **ENTER** button to confirm, use the **UP/DOWN** button to select **Display Invert, Temperature Unit** or **Language**.

Display Invert

Select **Display Invert**, press the **ENTER** button to confirm, present mode will blink on the display, use the **UP/DOWN** button to select **No** (normal display) or **Yes** (invert display), press the **ENTER** button to store. Press the **MENU** button back to the last menu or let the unit idle 30 seconds to exit menu mode.

Temperature Unit

Select **Temperature Unit**, press the **ENTER** button to confirm. Use the **UP/DOWN** button to select **°C** or **°F**, press the **ENTER** button to store. Press the **MENU** button back to the last menu or let the unit idle 30 seconds to exit menu mode.

Language

Select **Language**, press the **ENTER** button to confirm, present mode will blink on the display, use the **UP/DOWN** button to select **English** or **Chinese**. Press the **MENU** button back to the last menu or let the unit idle 30 seconds to exit menu mode.

Fixture Test

To select **Fixture Test**, press the **ENTER** button to confirm, use the **UP/DOWN** button to select **Auto Test** or **Manual Test**

Auto Test

Select **Auto Test**, press the **ENTER** button to confirm, the unit will run built-in programs to automatically test its functions. Press the **MENU** button back to the last menu or exit menu mode after auto test.

Manual Test

Select **Manual Test**, press the **ENTER** button to confirm, the present channel will show on the display, use the **UP/DOWN** button to select channel, press the **ENTER** button to confirm, then use the **UP/DOWN** button to adjust the value, press the **ENTER** button to store, the fixture will run as the channel value indicates. Press the **MENU** button back to the last menu or exit menu mode idling 30 seconds.

(The fixture will return to the previous DMX state after exiting Manual Test menu and the Manual Test parameters will be automatically saved after power off and restart.)

Information

To select **Information**, press the **ENTER** button to confirm, use the **UP/DOWN** button to select **Fixture Use Hour**, **LED Use Hour**, **Temperatue**, **Firmware Version**, **RDM UID** or **Error Logs**.

Fixture Use Hour

Select **Fixture Use Hour**, press the **ENTER** button to confirm, fixture use hour will show on the display, press the **MENU** button to exit.

LED Use Hour

To select **LED Use Hour**, press the **ENTER** button to confirm, use the **UP/DOWN** button to select **Total LED Hour**, **LED On Hour** or **LED Hours Reset**, press the **ENTER** button to store. Select **LED Hours Reset**, press the **ENTER** button to confirm, use the **UP/DOWN** button to select **No** or **Yes**, press the **ENTER** button to store. Select **Yes**, press the **ENTER** button to confirm, use the **UP/DOWN** button to set the password **050** to reset the LED hours, press the **ENTER** button to store. Press the **MENU** button back to the last menu or exit menu mode let the unit idle 30 seconds.

Temperature

Select **Temperature**, press the **ENTER** button to confirm, use the **UP/DOWN** button to select **LED**, press the **ENTER** button to confirm, the current temperature and max temperature of the unit will show on the display, press the **MENU** button to exit.

Firmware Version

Select **Firmware Version**, press the **ENTER** button to confirm, firmware version will show on the display, press the **MENU** button back to exit.

RDM UID

Select **RDM UID**, press the **ENTER** button to confirm, RDM UID will show on the display, press the **MENU** button back to exit.

Error Logs

Select **Error Logs**, press the **ENTER** button to confirm. Use the **UP/DOWN** button to select **Fixture Errors** or **Reset Error Log**, press the **ENTER** button to store. Select **Reset Error Log**, press the **ENTER** button to confirm. Use the **UP/DOWN** button to select **No** or **Yes**, press the **ENTER** button to store. Select **Yes**, press the **ENTER** button to confirm. Use the **UP/DOWN** button to set the password **050**, press the **ENTER** button to store. Press the **MENU** button back to the last menu or let the unit idle 30 seconds to exit menu mode.

Factory Restore

Select **Factory Restore**, press the **ENTER** button to confirm, use the **UP/DOWN** button to select **No** (normal) or **Yes** (the fixture will reset to factory settings), press **ENTER** button to store. Press the **MENU** button to exit.

RDM FUNCTIONS

Select the MANUFACTURER menu to display the manufacturer of the fixture.

Select the SOFTWARE VERSION menu and the program version number of the fixture will be displayed.

Select the DMX START ADDRESS menu to change the DMX512 address (001-512).

Select the DEVICE MODEL DESCRIPTION menu to display the model of the fixture.

Select the DEVICE LABEL menu to change the model of the fixture.

Select the DMX PERSONALITY menu to set the channel mode of the fixture (147/17/11/4/44/144 channel).

Select the DMX PERSONALITY DESCRIPTION menu to display the current channel mode of the fixture.

Select the DEVICE HOURS menu to display the running time of the fixture.

5.2 Home Position Adjustment

Press the MENU button into menu mode, then press the ENTER button for about 3 seconds into offset mode to adjust the home position. Select the function by pressing the ENTER button. Use the UP/DOWN button to choose the submenu, press the ENTER button to store and automatically return to the last menu. Press MENU button to exit.

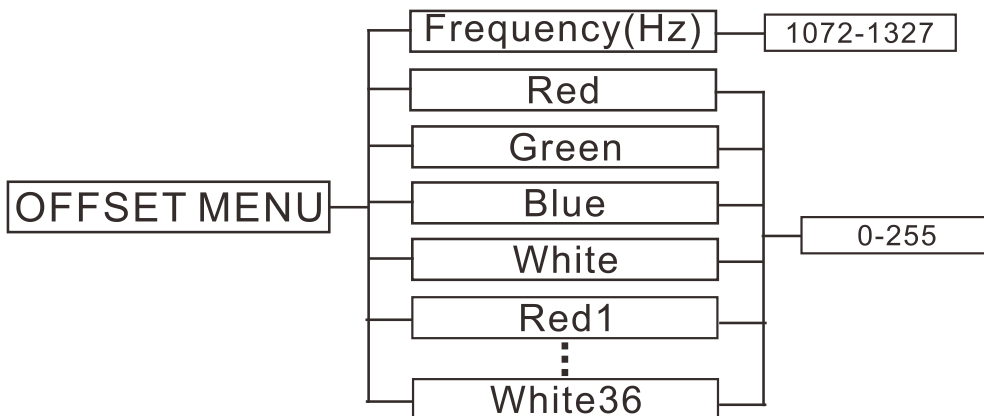

Frequency(Hz)

Enter offset mode, select **Frequency(Hz)**, press the **ENTER** button to confirm, the present position will blink on the display, use the **UP/DOWN** button to offset the value from 1072 to 1327, press the **ENTER** button to store. Press the **MENU** button to exit.

Red

Enter offset mode, select **Red**, press the **ENTER** button to confirm, the present position will blink on the display, use the **UP/DOWN** button to offset the value from 0 to 255, press the **ENTER** button to store. Press the **MENU** button to exit.

Green

Enter offset mode, select **Green**, press the **ENTER** button to confirm, the present position will blink on the display, use the **UP/DOWN** button to offset the value from 0 to 255, press the **ENTER** button to store. Press the **MENU** button to exit.

Blue

Enter offset mode, select **Blue**, press the **ENTER** button to confirm, the present position will blink on the display, use the **UP/DOWN** button to offset the value from 0 to 255, press the **ENTER** button to store. Press the **MENU** button to exit.

White

Enter offset mode, select **White**, press the **ENTER** button to confirm, the present position will blink on the display, use the **UP/DOWN** button to offset the value from 0 to 255, press the **ENTER** button to store. Press the **MENU** button to exit.

Red1

Enter offset mode, select **Red1**, press the **ENTER** button to confirm, the present position will blink on the display, use the **UP/DOWN** button to offset the value from 0 to 255, press the **ENTER** button to store. Press the **MENU** button to exit.

.....

White 36

Enter offset mode, select **White 36**, press the **ENTER** button to confirm, the present position will blink on the display, use the **UP/DOWN** button to offset the value from 0 to 255, press the **ENTER** button to store. Press the **MENU** button to exit.

6. Control By Universal DMX Controller

6.1 DMX512 Connection

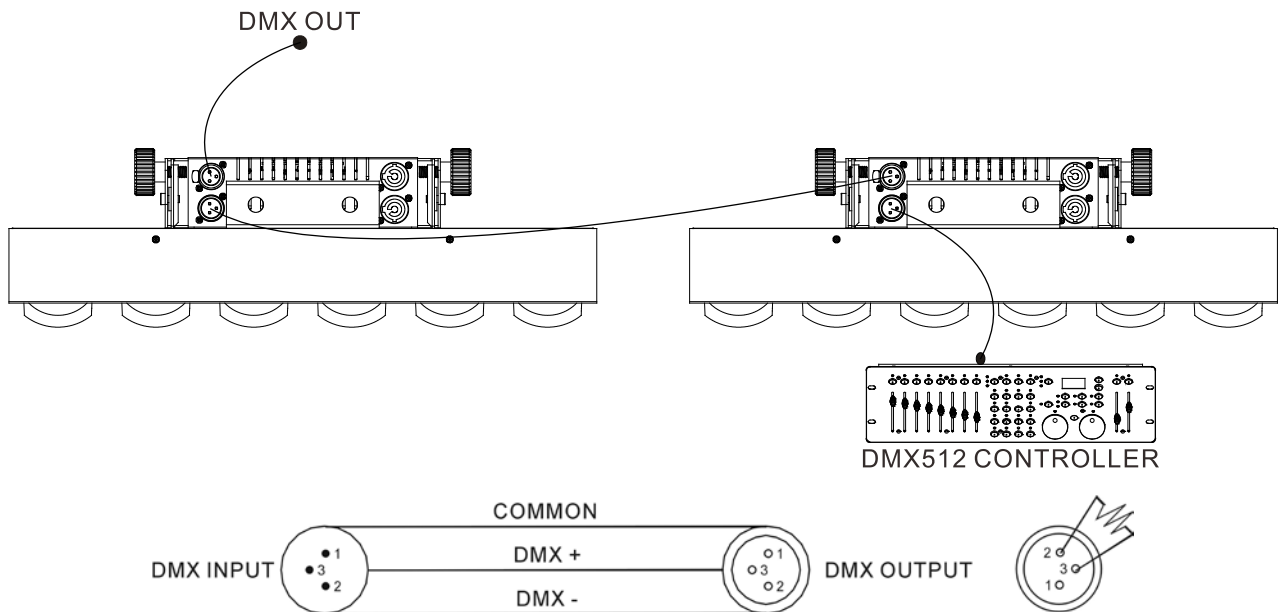

1. At last unit, the DMX cable has to be terminated with a terminator. Solder a 120-ohm 1/4W resistor between pin 2(DMX-) and pin 3(DMX+) into a 3-pin XLR-plug and plug it in the DMX-output of the last unit.
2. Connect the unit together in a “daisy chain” by XLR plug cable from the output of the unit to the input of the next unit. The cable can only be used in series and cannot be connected in parallel. DMX 512 is a very high-speed signal. Inadequate or damaged cables, soldered joints or corroded connectors can easily distort the signal and shut down the system.
3. The DMX output and input connectors are pass-through to maintain the DMX circuit, when one of the units’ power is disconnected.
4. Each lighting unit needs to have a DMX address to receive the data by the controller. The address number is between 1-512.
5. The end of the DMX 512 system should be terminated to reduce signal errors.
6. 3 pin XLR connectors are more popular than 5 pins XLR.
 - 3 pin XLR: Pin 1: GND, Pin 2: Negative signal (-), Pin 3: Positive signal (+)
 - 5 pin XLR: Pin 1: GND, Pin 2: Negative signal (-), Pin 3: Positive signal (+), Pin4, Pin5 not used.

6.2 Address Setting

If you use a universal DMX controller to control the units, you have to set DMX address from 1 to 512 so that the units can receive DMX signal.

Press the MENU button to enter menu mode, select DMX Settings, press the ENTER button to confirm, use the UP/DOWN button to select DMX Address, press the ENTER button to confirm, the present address will blink in the display, use the UP/DOWN button to adjust the address from 001 to 512, press the ENTER button to store. Press the MENU button back to the last menu or let the unit idle 30 seconds to exit menu mode.

Please refer to the following diagram to address your DMX512 channel for the first 4 units.

Channel mode	Unit 1 Address	Unit 2 Address	Unit 3 Address	Unit 4 Address
147 channels	1	148	295	442
17 channels	1	18	35	52
11 channels	1	12	23	34
4 channels	1	5	9	13
44 channels	1	45	89	133
144 channels	1	145	289	433

6.3 DMX512 Configuration

Please control the fixture by referring to the configurations below

Attentions:

1. The unit will maintain the last condition until reset if you cut-off the DMX signal.
2. For the channel Function, keep the value for about 3 seconds, then the corresponding function will take into effect.

147 Channels (Mode 1):

CHANNEL	VALUE	FUNCTION
1	000-255	RED1 0%→100%
2	000-255	GREEN1 0%→100%
3	000-255	BLUE1 0%→100%
4	000-255	WHITE1 0%→100%
5	000-255	RED2 0%→100%
6	000-255	GREEN2 0%→100%
7	000-255	BLUE2 0%→100%
8	000-255	WHITE2 0%→100%
.....
141	000-255	RED36 0%→100%
142	000-255	GREEN36 0%→100%
143	000-255	BLUE36 0%→100%
144	000-255	WHITE36 0%→100%
145	000-007 008-015 016-131 132-139 140-181 182-189 190-231 232-239 240-247 248-255	STROBE Close Open Strobe from Slow to Fast Open Fast Close Slow Open Open Fast Open Slow Close Open Random Strobe Open
146	000-255	DIMMER 0%→100%
147	000-255	DIMMER FINE

17 Channels (Mode 2):

CHANNEL	VALUE	FUNCTION
1	000-255	RED (RING 1) 0%→100%
2	000-255	GREEN (RING 1) 0%→100%
3	000-255	BLUE (RING 1) 0%→100%
4	000-255	WHITE (RING 1) 0%→100%
5	000-255	RED (RING 2) 0%→100%
6	000-255	GREEN (RING 2) 0%→100%
7	000-255	BLUE (RING 2) 0%→100%
8	000-255	WHITE (RING 2) 0%→100%
9	000-255	RED (RING 3) 0%→100%
10	000-255	GREEN (RING 3) 0%→100%
11	000-255	BLUE (RING 3) 0%→100%
12	000-255	WHITE (RING 3) 0%→100%
13	000-009 010-014 015-019 020-024 025-029 030-034 035-039 040-044 045-049 050-054 055-059 060-064 065-069 070-074 075-079 080-084 085-089	COLOR MACRO Open LEE 790-Moroccan Pink LEE 157-Pink LEE 332-Special Rose Pink LEE 328-Follies Pink LEE 345-Fuchsia Pink LEE 194-Surprise Pink LEE 181-Congo Blue LEE 071-Tokyo Blue LEE 120-Deep Blue LEE 079-Just Blue LEE 132-Medium Blue LEE 200-Double CT Blue LEE 161-State Blue LEE 201-Full CT Blue LEE 202-Half CT Blue LEE 117-Steel Blue

	090-094 095-099 100-104 105-109 110-114 115-119 120-124 125-129 130-134 135-139 140-144 145-149 150-154 155-159 160-164 165-169 170-174 175-179 180-201 202-207 208-229 230-234 235-239 240-244 245-249 250-255	LEE 353-Lighter Blue LEE 118-Light Blue LEE 116-Medium Blue Green LEE 124-Dark Green LEE 139-Primary Green LEE 089-Moss Green LEE 122-Fern Green LEE 738-JAS Green LEE 088-Lime Green LEE 100-Spring Yellow LEE 104-Deep Amber LEE 179-Chrome Orange LEE 105-Orange LEE 021-Gold Amber LEE 778-Millennium Gold LEE 135-Deep Gold Amber LEE 164-Flame Red Open Clockwise Rotation, Fast to Slow Stop Counter-clockwise Rotation, Slow to Fast Open Random Color: Fast Random Color: Medium Random Color: Slow Open
14	000-007 008-015 016-131 132-139 140-181 182-189 190-231 232-239 240-247 248-255	STROBE Close Open Strobe from Slow to Fast Open Fast Close Slow Open Open Fast Open Slow Close Open Random Strobe Open
15	000-255	DIMMER 0%→100%
16	000-255	DIMMER FINE
17	000-029 030-039 040-049 050-059 060-069	SPECIAL FUNCTION Null Dimmer Curve Linear Dimmer Curve Square Law Dimmer Curve Inv SQ Law Dimmer Curve S

	070-079	Null
	080-089	Null
	090-099	Null
	100-109	Null
	110-119	Null
	120-129	Null
	130-139	Null
	140-179	Null
	180-189	Dimmer Speed Fast
	190-199	Dimmer Speed Smooth
	200-209	Null
	210-219	Null
	220-229	Null
	230-255	Null

11 Channels (Mode 3):

CHANNEL	VALUE	FUNCTION
1	000-255	RED 0%→100%
2	000-255	GREEN 0%→100%
3	000-255	BLUE 0%→100%
4	000-255	WHITE 0%→100%
5	000-009	COLOR MACRO Open
	010-014	LEE 790-Moroccan Pink
	015-019	LEE 157-Pink
	020-024	LEE 332-Special Rose Pink
	025-029	LEE 328-Follies Pink
	030-034	LEE 345-Fuchsia Pink
	035-039	LEE 194-Surprise Pink
	040-044	LEE 181-Congo Blue
	045-049	LEE 071-Tokyo Blue
	050-054	LEE 120-Deep Blue
	055-059	LEE 079-Just Blue
	060-064	LEE 132-Medium Blue
	065-069	LEE 200-Double CT Blue
	070-074	LEE 161-State Blue
	075-079	LEE 201-Full CT Blue
	080-084	LEE 202-Half CT Blue
	085-089	LEE 117-Steel Blue

	090-094 095-099 100-104 105-109 110-114 115-119 120-124 125-129 130-134 135-139 140-144 145-149 150-154 155-159 160-164 165-169 170-174 175-179 180-201 202-207 208-229 230-234 235-239 240-244 245-249 250-255	LEE 353-Lighter Blue LEE 118-Light Blue LEE 116-Medium Blue Green LEE 124-Dark Green LEE 139-Primary Green LEE 089-Moss Green LEE 122-Fern Green LEE 738-JAS Green LEE 088-Lime Green LEE 100-Spring Yellow LEE 104-Deep Amber LEE 179-Chrome Orange LEE 105-Orange LEE 021-Gold Amber LEE 778-Millennium Gold LEE 135-Deep Gold Amber LEE 164-Flame Red Open Clockwise Rotation, Fast to Slow Stop Counter-clockwise Rotation, Slow to Fast Open Random Color: Fast Random Color: Medium Random Color: Slow Open
6	000-047 048-095 096-135 136-175 176-215 216-255	MODE Blackout Line Effect (see channel 7-1) Number 1 to 9 (see channel 7-2) Letter A to Z (see channel 7-3) Letter a to z (see channel 7-4) Blackout
7-1	000-007 008-015 016-023 024-031 032-039 040-047 048-055 056-063 064-071 072-079 080-087 088-095 096-103	LINE EFFECT No Function Effect 01 Effect 02 Effect 03 Effect 04 Effect 05 Effect 06 Effect 07 Effect 08 Effect 09 Effect 10 Effect 11 Effect 12

	104-111 112-119 120-127 128-135 136-143 144-151 152-159 160-167 168-175 176-183 184-191 192-199 200-207 208-215 216-223 224-231 232-239 240-247 248-255	Effect 13 Effect 14 Effect 15 Effect 16 Effect 17 Effect 18 Effect 19 Effect 20 Effect 21 Effect 22 Effect 23 Effect 24 Effect 25 Effect 26 Effect 27 Effect 28 Effect 29 Effect 30 Effect 31
7-2	000-025 026-048 049-071 072-094 095-117 118-140 141-163 164-186 187-209 210-232 233-255	NUMBER 1 to 9 No Function Number-0 Number-1 Number-2 Number-3 Number-4 Number-5 Number-6 Number-7 Number-8 Number-9
7-3	000-021 022-030 031-039 040-048 049-057 058-066 067-075 076-084 085-093 094-102 103-111 112-120 121-129 130-138 139-147	LETTER A to Z No Function Letter-A Letter-B Letter-C Letter-D Letter-E Letter-F Letter-G Letter-H Letter-I Letter-J Letter-K Letter-L Letter-M Letter-N

	148-156 157-165 166-174 175-183 184-192 193-201 202-210 211-219 220-228 229-237 238-246 247-255	Letter-O Letter-P Letter-Q Letter-R Letter-S Letter-T Letter-U Letter-V Letter-W Letter-X Letter-Y Letter-Z
7-4	000-021 022-030 031-039 040-048 049-057 058-066 067-075 076-084 085-093 094-102 103-111 112-120 121-129 130-138 139-147 148-156 157-165 166-174 175-183 184-192 193-201 202-210 211-219 220-228 229-237 238-246 247-255	LETTER a to z No Function Letter-a Letter-b Letter-c Letter-d Letter-e Letter-f Letter-g Letter-h Letter-i Letter-j Letter-k Letter-l Letter-m Letter-n Letter-o Letter-p Letter-q Letter-r Letter-s Letter-t Letter-u Letter-v Letter-w Letter-x Letter-y Letter-z
8	000-007 008-015 016-131 132-139 140-181 182-189	STROBE Close Open Strobe from Slow to Fast Open Fast Close Slow Open Open

	190-231 232-239 240-247 248-255	Fast Open Slow Close Open Random Strobe Open
9	000-255	DIMMER 0%→100%
10	000-255	DIMMER FINE
11	000-029 030-039 040-049 050-059 060-069 070-079 080-089 090-099 100-109 110-119 120-129 130-139 140-179 180-189 190-199 200-209 210-219 220-229 230-255	SPECIAL FUNCTION Null Dimmer Curve Linear Dimmer Curve Square Law Dimmer Curve Inv SQ Law Dimmer Curve S Null Null Null Null Null Null Null Null Dimmer Speed Fast Dimmer Speed Smooth Null Null Null Null

4 Channels (Mode 4):

CHANNEL	VALUE	FUNCTION
1	000-255	RED 0%→100%
2	000-255	GREEN 0%→100%
3	000-255	BLUE 0%→100%
4	000-255	WHITE 0%→100%

44 Channels (Mode 5):

CHANNEL	VALUE	FUNCTION
1	000-255	LED1 0%→100%
2	000-255	LED2 0%→100%
3	000-255	LED3 0%→100%
4	000-255	LED4 0%→100%
5	000-255	LED5 0%→100%
6	000-255	LED6 0%→100%
7	000-255	LED7 0%→100%
8	000-255	LED8 0%→100%
9	000-255	LED9 0%→100%
10	000-255	LED10 0%→100%
11	000-255	LED11 0%→100%
12	000-255	LED12 0%→100%
13	000-255	LED13 0%→100%
14	000-255	LED14 0%→100%
15	000-255	LED15 0%→100%
16	000-255	LED16 0%→100%
17	000-255	LED17 0%→100%
18	000-255	LED18 0%→100%
19	000-255	LED19 0%→100%

20	000-255	LED20 0%→100%
21	000-255	LED21 0%→100%
22	000-255	LED22 0%→100%
23	000-255	LED23 0%→100%
24	000-255	LED24 0%→100%
25	000-255	LED25 0%→100%
26	000-255	LED26 0%→100%
27	000-255	LED27 0%→100%
28	000-255	LED28 0%→100%
29	000-255	LED29 0%→100%
30	000-255	LED30 0%→100%
31	000-255	LED31 0%→100%
32	000-255	LED32 0%→100%
33	000-255	LED33 0%→100%
34	000-255	LED34 0%→100%
35	000-255	LED35 0%→100%
36	000-255	LED36 0%→100%
37	000-009 010-014 015-019 020-024 025-029 030-034	COLOR MACRO Open LEE 164-Flame Red LEE 135-Deep Gold Amber LEE 778-Millennium Gold LEE 021-Gold Amber LEE 105-Orange

	035-039 040-044 045-049 050-054 055-059 060-064 065-069 070-074 075-079 080-084 085-089 090-094 095-099 100-104 105-109 110-114 115-119 120-124 125-129 130-134 135-139 140-144 145-149 150-154 155-159 160-164 165-169 170-174 175-179 180-201 202-207 208-229 230-234 235-239 240-244 245-249 250-255	LEE 179-Chrome Orange LEE 104-Deep Amber LEE 100-Spring Yellow LEE 088-Lime Green LEE 738-JAS Green LEE 122-Fern Green LEE 089-Moss Green LEE 139-Primary Green LEE 124-Dark Green LEE 116-Medium Blue Green LEE 118-Light Blue LEE 353-Lighter Blue LEE 117-Steel Blue LEE 202-Half CT Blue LEE 201-Full CT Blue LEE 161-State Blue LEE 200-Double CT Blue LEE 132-Medium Blue LEE 079-Just Blue LEE 120-Deep Blue LEE 071-Tokyo Blue LEE 181-Congo Blue LEE 194-Surprise Pink LEE 345-Fuchsia Pink LEE 328-Follies Pink LEE 332-Special Rose Pink LEE 157-Pink LEE 790-Moroccan Pink Open Clockwise Rotation, Fast to Slow Stop Counter-clockwise Rotation, Slow to Fast Open Random Color: Fast Random Color: Medium Random Color: Slow Open
38	000-009 010-014 015-019 020-024 025-029 030-034 035-039 040-044 045-049	BACKGROUND COLOR MACRO Open LEE 790-Moroccan Pink LEE 157-Pink LEE 332-Special Rose Pink LEE 328-Follies Pink LEE 345-Fuchsia Pink LEE 194-Surprise Pink LEE 181-Congo Blue LEE 071-Tokyo Blue

	050-054 055-059 060-064 065-069 070-074 075-079 080-084 085-089 090-094 095-099 100-104 105-109 110-114 115-119 120-124 125-129 130-134 135-139 140-144 145-149 150-154 155-159 160-164 165-169 170-174 175-179 180-201 202-207 208-229 230-234 235-239 240-244 245-249 250-255	LEE 120-Deep Blue LEE 079-Just Blue LEE 132-Medium Blue LEE 200-Double CT Blue LEE 161-State Blue LEE 201-Full CT Blue LEE 202-Half CT Blue LEE 117-Steel Blue LEE 353-Lighter Blue LEE 118-Light Blue LEE 116-Medium Blue Green LEE 124-Dark Green LEE 139-Primary Green LEE 089-Moss Green LEE 122-Fern Green LEE 738-JAS Green LEE 088-Lime Green LEE 100-Spring Yellow LEE 104-Deep Amber LEE 179-Chrome Orange LEE 105-Orange LEE 021-Gold Amber LEE 778-Millennium Gold LEE 135-Deep Gold Amber LEE 164-Flame Red Open Clockwise Rotation, Fast to Slow Stop Counter-clockwise Rotation, Slow to Fast Open Random Color: Fast Random Color: Medium Random Color: Slow Open
39	000-047 048-095 096-135 136-175 176-215 216-255	MODE Blackout Line Effect (see channel 40-1) Number 1 to 9 (see channel 40-2) Letter A to Z (see channel 40-3) Letter a to z (see channel 40-4) Blackout
40-1	000-007 008-015 016-023 024-031 032-039	LINE EFFECT No Function Effect 01 Effect 02 Effect 03 Effect 04

	040-047 048-055 056-063 064-071 072-079 080-087 088-095 096-103 104-111 112-119 120-127 128-135 136-143 144-151 152-159 160-167 168-175 176-183 184-191 192-199 200-207 208-215 216-223 224-231 232-239 240-247 248-255	Effect 05 Effect 06 Effect 07 Effect 08 Effect 09 Effect 10 Effect 11 Effect 12 Effect 13 Effect 14 Effect 15 Effect 16 Effect 17 Effect 18 Effect 19 Effect 20 Effect 21 Effect 22 Effect 23 Effect 24 Effect 25 Effect 26 Effect 27 Effect 28 Effect 29 Effect 30 Effect 31
40-2	000-025 026-048 049-071 072-094 095-117 118-140 141-163 164-186 187-209 210-232 233-255	NUMBER 1 to 9 No Function Number-0 Number-1 Number-2 Number-3 Number-4 Number-5 Number-6 Number-7 Number-8 Number-9
40-3	000-021 022-030 031-039 040-048 049-057 058-066 067-075	LETTER A to Z No Function Letter-A Letter-B Letter-C Letter-D Letter-E Letter-F

	076-084 085-093 094-102 103-111 112-120 121-129 130-138 139-147 148-156 157-165 166-174 175-183 184-192 193-201 202-210 211-219 220-228 229-237 238-246 247-255	Letter-G Letter-H Letter-I Letter-J Letter-K Letter-L Letter-M Letter-N Letter-O Letter-P Letter-Q Letter-R Letter-S Letter-T Letter-U Letter-V Letter-W Letter-X Letter-Y Letter-Z
40-4	000-021 022-030 031-039 040-048 049-057 058-066 067-075 076-084 085-093 094-102 103-111 112-120 121-129 130-138 139-147 148-156 157-165 166-174 175-183 184-192 193-201 202-210 211-219 220-228 229-237 238-246	LETTER a to z No Function Letter-a Letter-b Letter-c Letter-d Letter-e Letter-f Letter-g Letter-h Letter-i Letter-j Letter-k Letter-l Letter-m Letter-n Letter-o Letter-p Letter-q Letter-r Letter-s Letter-t Letter-u Letter-v Letter-w Letter-x Letter-y

	247-255	Letter-z
41	000-007 008-015 016-131 132-139 140-181 182-189 190-231 232-239 240-247 248-255	STROBE Close Open Strobe from Slow to Fast Open Fast Close Slow Open Open Fast Open Slow Close Open Random Strobe Open
42	000-255	DIMMER 0%→100%
43	000-255	DIMMER FINE
44	000-029 030-039 040-049 050-059 060-069 070-079 080-089 090-099 100-109 110-119 120-129 130-139 140-179 180-189 190-199 200-209 210-219 220-229 230-255	SPECIAL FUNCTION Null Dimmer Curve Linear Dimmer Curve Square Law Dimmer Curve Inv SQ Law Dimmer Curve S Null Null Null Null Null Null Null Null Dimmer Speed Fast Dimmer Speed Smooth Null Null Null Null

144 Channels (Mode 6):

CHANNEL	VALUE	FUNCTION
1	000-255	RED1 0%→100%
2	000-255	GREEN1 0%→100%
3	000-255	BLUE1 0%→100%
4	000-255	WHITE1 0%→100%
5	000-255	RED2 0%→100%
6	000-255	GREEN2 0%→100%
7	000-255	BLUE2 0%→100%
8	000-255	WHITE2 0%→100%
.....
141	000-255	RED36 0%→100%
142	000-255	GREEN36 0%→100%
143	000-255	BLUE36 0%→100%
144	000-255	WHITE36 0%→100%

7. Error Information

Error codes are shown continuously in the display when the fixture fails and they will not disappear until the fixture is repaired.

1. Led Temp. Error

Check whether the temperature detecting board is normal.

Check whether the components of the temperature detecting board are damaged.

Check whether the lead on the temperature detecting board is installed in place or disconnected.

2. LED Too Hot Off

When the fixture temperature reaches 70°C, it will automatically turn off to protect the fixture.

3. LED Timeout Use

8. Troubleshooting

Following are a few common problems that may occur during operation. Here are some suggestions for troubleshooting:

A. The unit does not work and no light

1. Check the connected power.
2. Measure the voltage.
3. Check the power indicator to see whether it can be lit up or not.

B. Not responding to the DMX controller

1. Check whether the DMX connectors and the DMX cables are connected correctly.
2. Check whether the DMX address is correctly set.
3. If the intermittent DMX signal problem occurs, check whether the XLR socket and the signal cable are well connected.
4. Try it with another DMX controller.
5. Check whether the DMX cables run near or alongside to the high-voltage cables, which may damage or interfere with the signal circuit.

C. One of the channels is not working well

1. The stepper motor might be damaged or the cable connected to the PCB might be broken.
2. The motor's drive IC on the PCB might be out of condition.

9. Fixture Cleaning

It is absolutely essential that the fixture is kept clean to ensure the maximum light-output and allow the fixture to function reliably throughout its life. The fixture must be cleaned regularly to avoid dust, dirt and smoke-fluid residues building up on or within the fixture. The cleaning frequency depends on the application environment. Clean the fixture immediately if the dust enters it to avoid damage to the optical lens due to excessive dust.

- A soft lint-free cloth moistened with any good glass cleaning fluid is recommended, under no circumstances should solvents be used.
- Always dry the parts carefully.
- Clean the external optical lens at least every 20 days.

Innovation, Quality, Performance