

# Acme®

## *THUNDER*

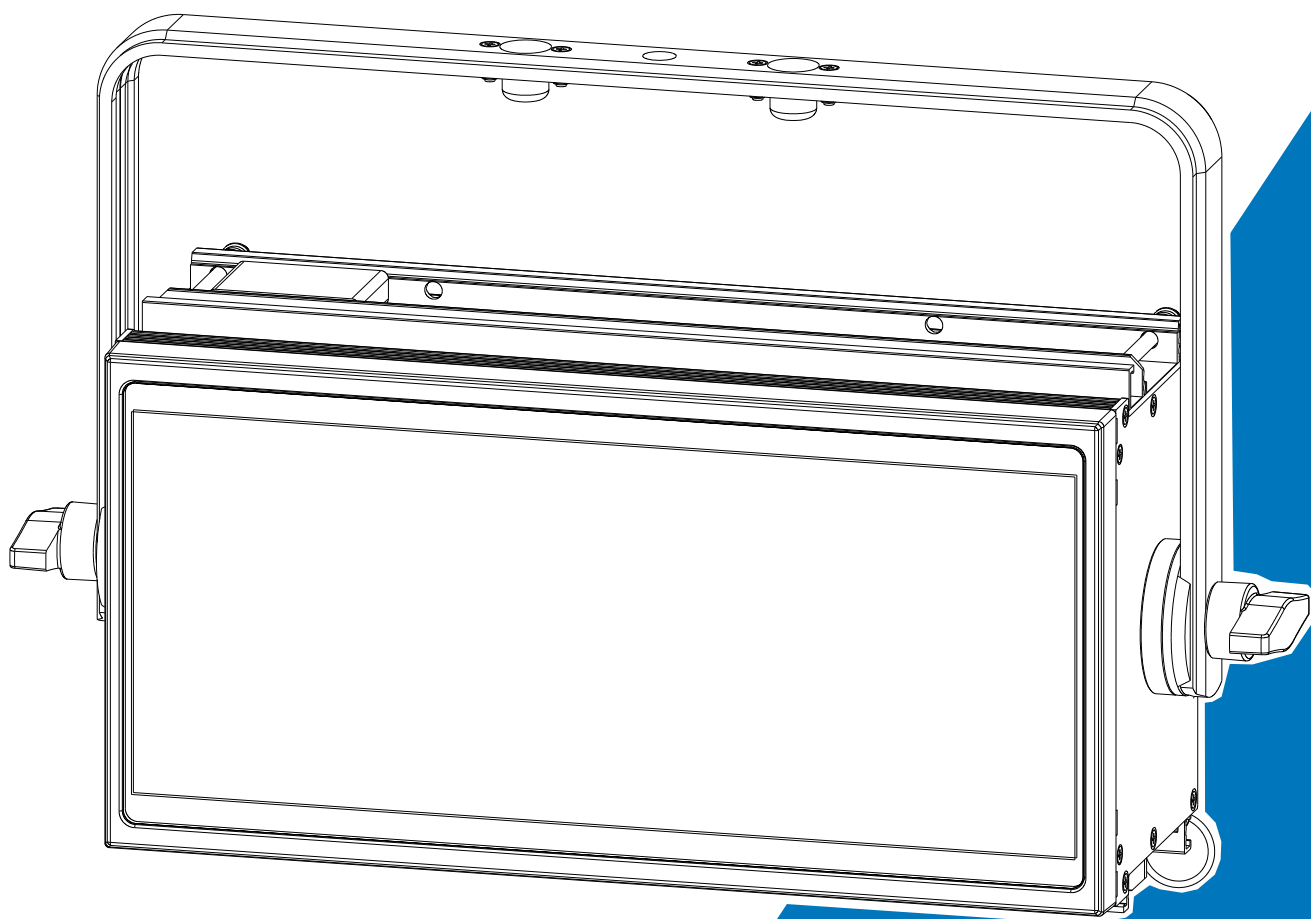

## User Manual

Please read the instruction carefully before use

# CONTENTS

01/ Safety Instructions.....	2
02/ Technical Specifications .....	4
03/ Control Panel.....	6
04/ Fixture Installation.....	7
05/ How To Set The Unit.....	12
5.1 Main Functions .....	12
5.2 Home Position Adjustment .....	22
06/ Control By Universal DMX Controller.....	26
6.1 DMX512 Connection.....	26
6.2 Address Setting.....	27
6.3 DMX512 Configuration .....	27
07/ Error Information .....	32
08/ Troubleshooting .....	33
09/ Fixture Cleaning.....	34

## 01/ Safety Instructions



Please read the instruction carefully which includes important information about the installation, usage and maintenance.

### WARNING

Please keep this User Guide for future consultation. If you sell the unit to another user, be sure that they also receive this instruction manual.

#### Important:

**Damages caused by the disregard of this user manual are not subject to warranty. The dealer will not accept liability for any resulting defects or problems.**

- Unpack and check carefully to ensure that there is no transportation damage before using the unit.
- This product is suitable for wet locations. Do not immerse in water.
- DO install and operate by qualified operator.
- DO NOT allow children to operate the fixture.
- Use safety chain when fixing the unit. Handle the unit by carrying its base instead of head only.
- The unit must be installed in a location with adequate ventilation, at least 50cm from adjacent surfaces.
- Be sure that no ventilation slots is blocked, otherwise the unit will be overheated.
- Before operation, ensure that you are connecting this product to the proper voltage in accordance with the specifications in this manual or on the product's specification label.
- It's important to ground the yellow/green conductor to earth in order to avoid electric shock.
- Minimum ambient temperature TA: 0°C. Maximum ambient temperature TA: 40°C. Do not operate this product at a lower or higher temperature.
- DO NOT connect the device to any dimmer pack.
- Keep flammable materials away from the fixture while operating to avoid fire hazard.
- Make sure the power cord is not crimped or damaged; replace it immediately if damaged.
- Unit's surface temperature may reach up to 75°C. DO NOT touch the housing bare-handed during its operation.
- Avoid any flammable liquids, water or metal from entering the unit. Once it happens, cut

off the mains power immediately.

- DO NOT operate in a dirty or dusty environment. DO clean the fixture regularly.
- DO NOT touch any wire during operation as there might be a hazard of electric shock.
- Avoid entanglement of the power cord with other wires.
- The minimum distance to objects/surface must be more than 0.5 meters.
- In the event of serious operating problem, stop using the unit immediately.
- Never turn on and off the unit time after time.
- The housing, the lenses, or the ultraviolet filter must be replaced if they are visibly damaged.
- DO NOT open the housing as there are no user serviceable parts inside.
- DO NOT attempt to operate this unit if it becomes damaged. DO NOT attempt any repairs yourself. Repairs carried out by unskilled people can lead to damage or malfunction. Please contact the nearest authorized technical assistance center if needed.
- Disconnect this product from its power source before servicing.
- DO use the original packaging if the device is to be transported.
- Avoid direct eye exposure to the light source while the product is on.
- DO NOT operate this product if you see damage on the housing, shields, or cables. Have the damaged parts replaced by an authorized technician at once.

## 02/ Technical Specifications

<b>Power Voltage</b>	100-240V~ 50/60Hz	
<b>Power Consumption</b>	515W	
<b>Light Source</b>	1188x0.8W RGBW LED	
<b>Color Temperature</b>	2500K-8000K	
<b>Beam Angle</b>	110°	
<b>Dimmer/Strobe</b>	0-100% smooth dimming; High output strobe effect	
<b>Control</b>	DMX Channel	4 Channel (8 bit)/8 Channel (16 bit)/ 8 Channel/9 Channel (16 bit)/16 Channel
	Control Mode	DMX512
		RDM Primary/Secondary Mode
	Firmware Upgrade	Firmware Upgrade via DMX link
<b>Construction</b>	Display	OLED display
	Data In/Out	3-pin IP XLR (5-pin IP XLR is optional)
	Power In/Out	Waterproof Power Connector in/out
	Protection Rating	IPX4
<b>Features</b>	3 LED zones can be controlled individually	
	Variable CTO	
	High brightness, smooth color mixing, powerful wash effect	
<b>Dimensions</b>	503x183x318mm	19.8"x7.2"x12.5" in
<b>Weight</b>	10.5kgs	23.1lbs

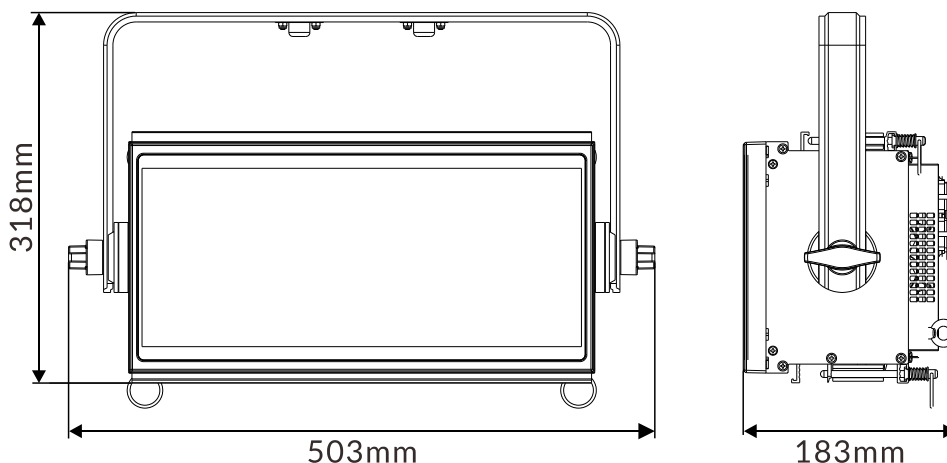

Photometric Diagram:

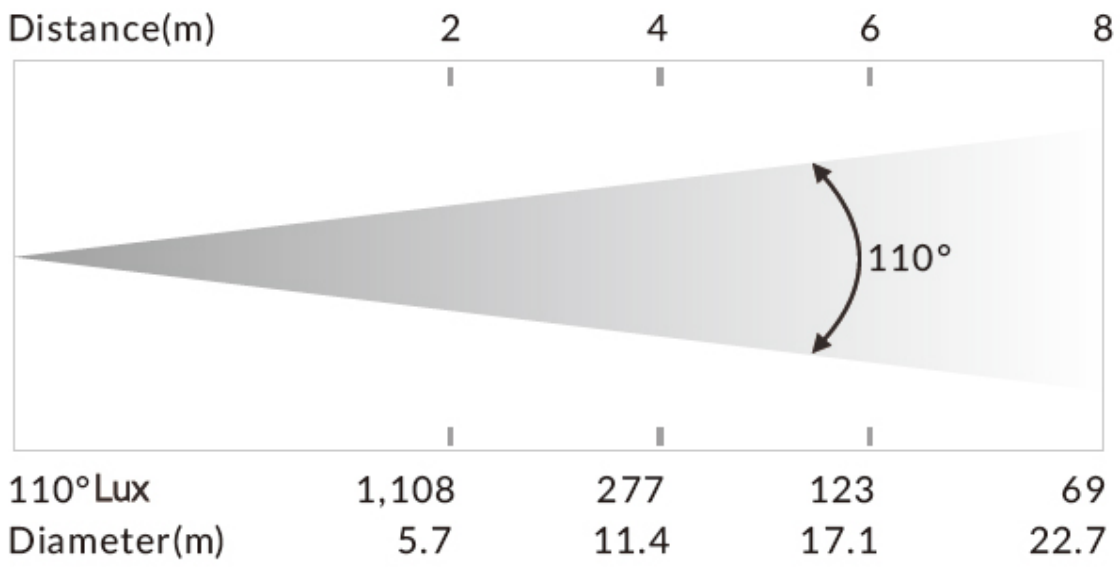

## 03/ Control Panel

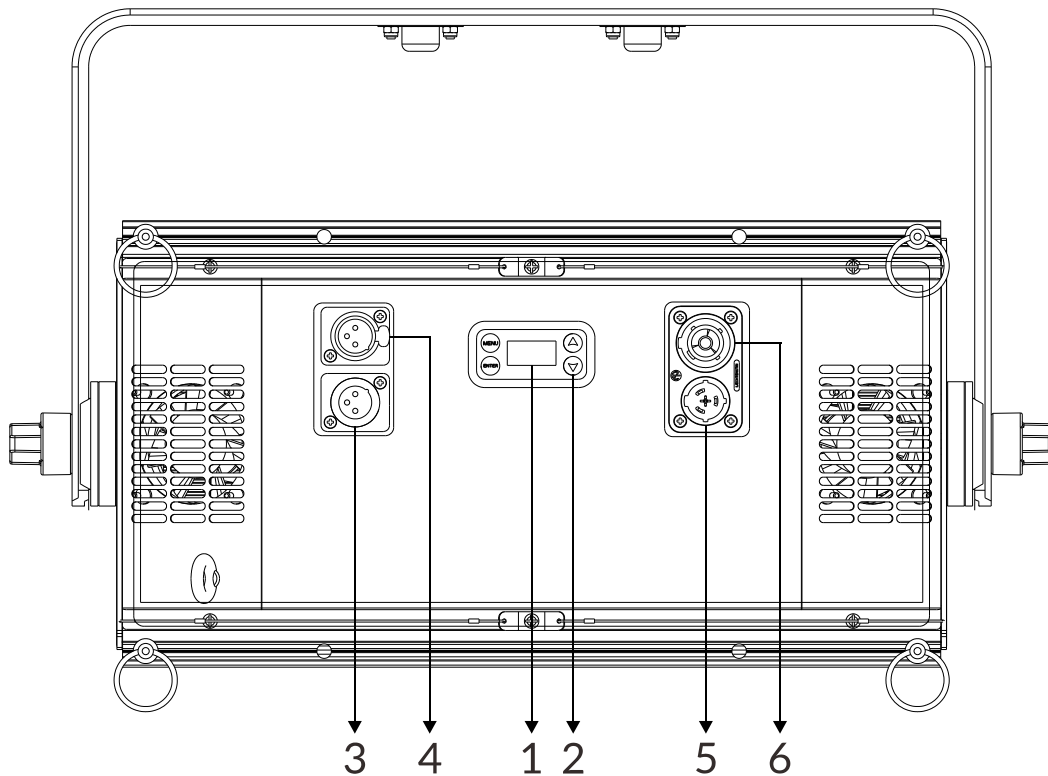

1. Display	To show the various menus and the selected function	
2. Buttons	MENU	To enter into menu or leave the menu
	▲ UP	To go backward to move up in the menu
	▼ DOWN	To go forward to move down in the menu
	ENTER	To perform the desired functions
3. DMX IN	For DMX512 link, use 3-pin XLR cable to link the unit and DMX controller to input DMX signal (5-pin XLR cable is optional)	
4. DMX OUT	For DMX512 link, use 3-pin XLR cable to link the next units to output DMX signal (5-pin XLR cable is optional)	
5. POWER IN	To connect to supply power	
6. POWER OUT	To connect to the next fixture	

## 04/ Fixture Installation

---

### **IPX4 RATED**

An IP rated lighting fixture is commonly installed in outdoor environments and has been designed with an enclosure that effectively protects the ingress (entry) of external foreign objects such as dust and water. The **International Protection (IP)** rating system is commonly expressed as “IP” (Ingress Protection) followed by two numbers (i.e. IP20) where the numbers define the degree of protection. The first digit (Foreign Bodies Protection) indicates the extent of protection against particles entering the fixture, and the second digit (Water Protection) indicates the extent of protection against water entering the fixture.

**An IPX4 rated lighting fixture has been designed for temporary outdoor environments. It has NOT been tested to protect against the ingress of dust (X) but has been tested to protect from splash of water in any direction (4).**

### **PERMANENT OUTDOOR AND/OR MARINE/COSTAL INSTALLATIONS**

Please note although this fixture is IP rated, this fixture is **NOT** suitable for permanent outdoor and/or marine environment installations. Installing this fixture in permanent outdoor and/or marine environment installation may cause corrosion and/or excessive wear to the interior and/or exterior components of the fixture. Damages and/or performance issues resulting from installation in a permanent outdoor and/or marine environment installation will void the manufacturer’s warranty and will **NOT** be subject to any warranty claims and/or repairs.



- ▶ DO install and operate by qualified operator. Fixture(s) should be installed in areas outside walking paths, seating areas, or away from areas where unauthorized personnel might reach the fixture by hand. NEVER stand directly below the fixture(s) when rigging, removing or servicing.
- ▶ Always ensure that the unit is firmly fixed to avoid vibration and slipping off during operation. Ensure that the trussing or area of installation must be able to hold 10 times the weight without any deformation. Always attach a safety cable that can hold at least 12 times the weight of the fixture whenever installing this fixture in a suspended environment to ensure that the fixture will not fall if the clamp fails.
- ▶ This fixture is fully operational in three different mounting positions: hanging on trussing, mounted sideways on trussing, or set on a flat level surface. Always use and install the supplied safety cable as a safety measure to prevent accidental damage and/or injury in the event the clamp fails.

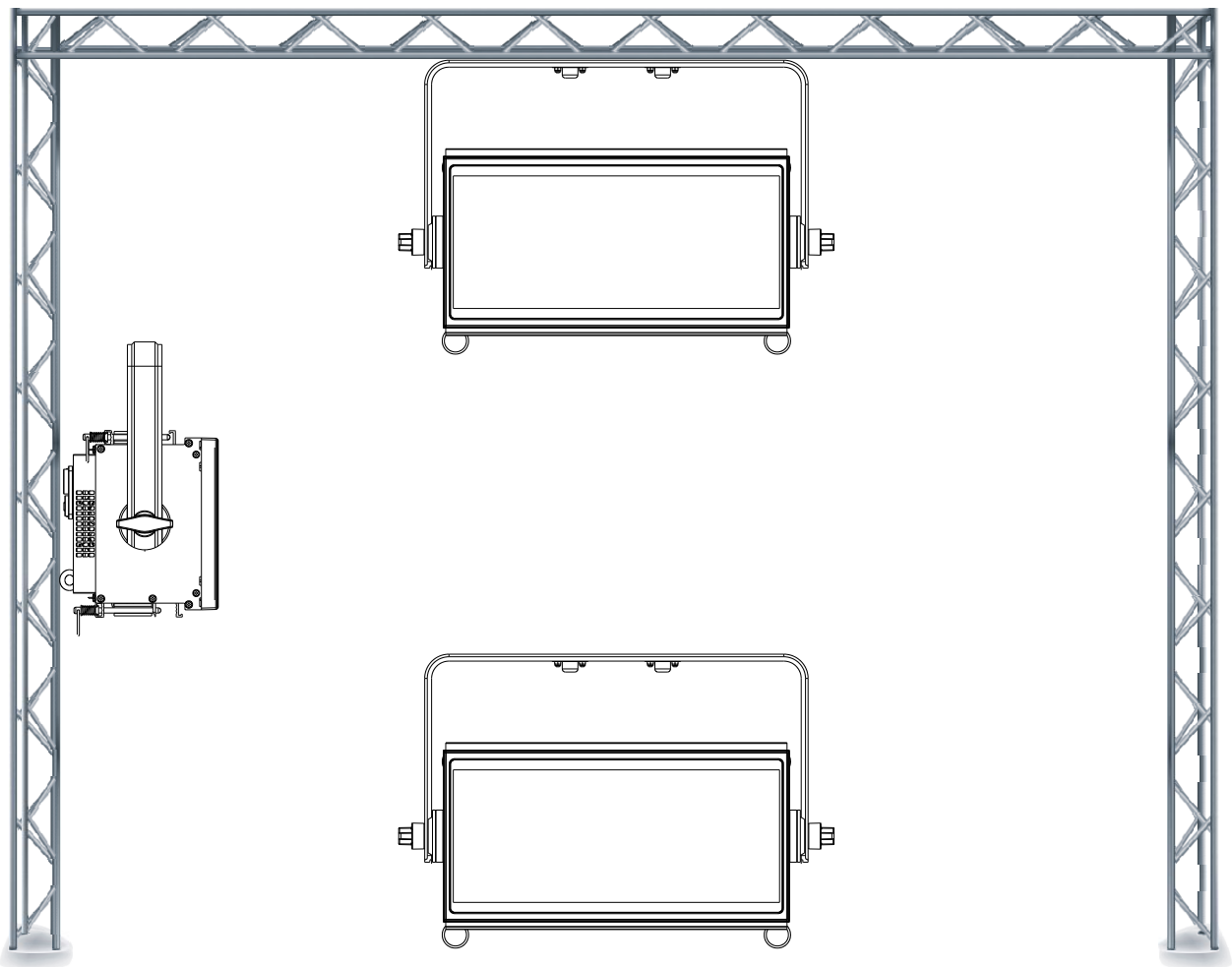

### Steps for installing omega bracket:

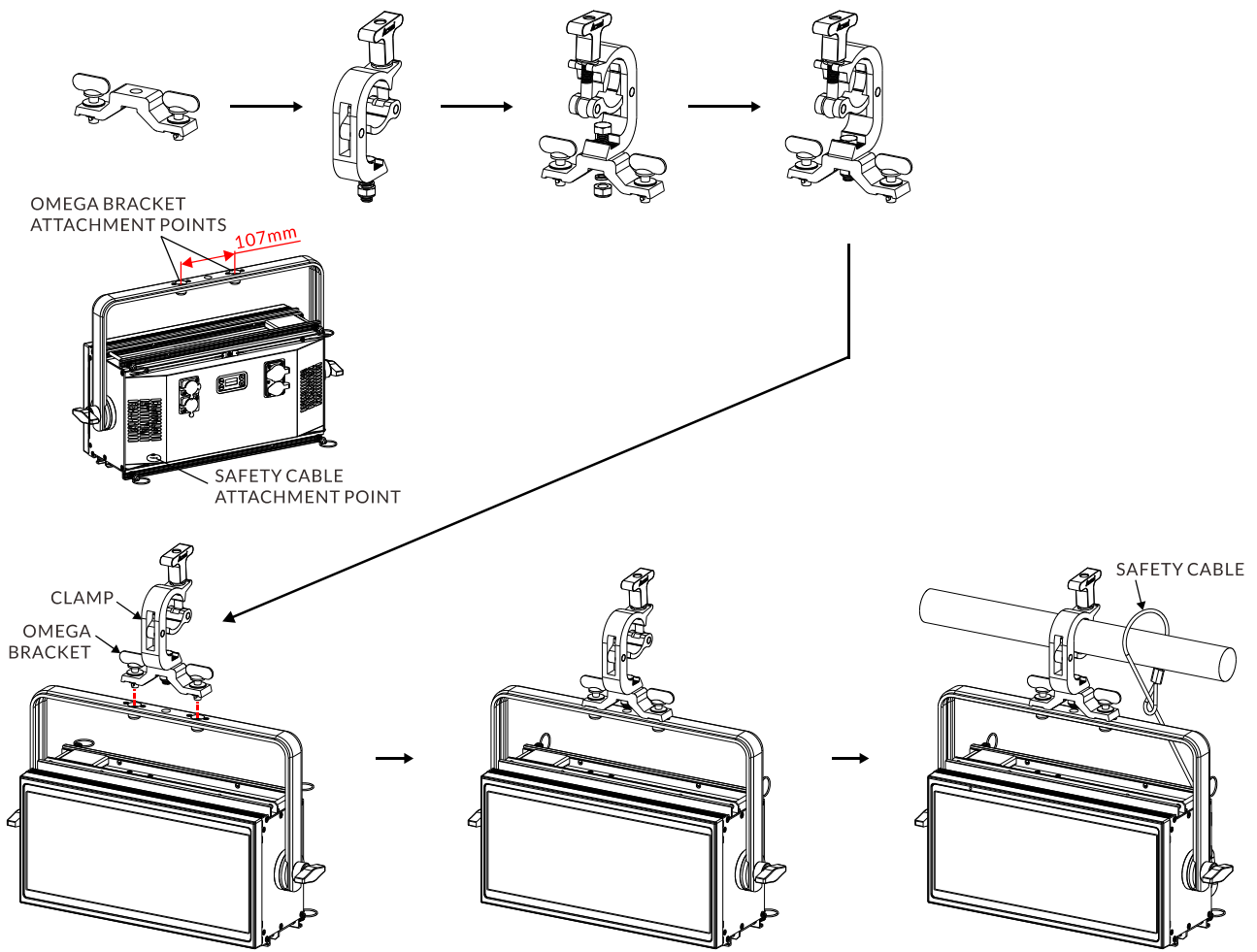

### Steps for installing clamp:

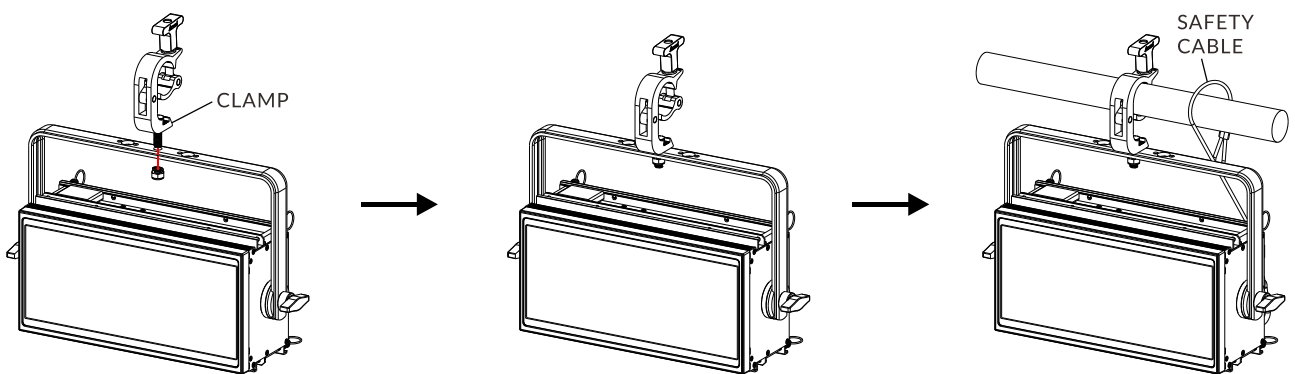

Steps for installing the hanging bracket:

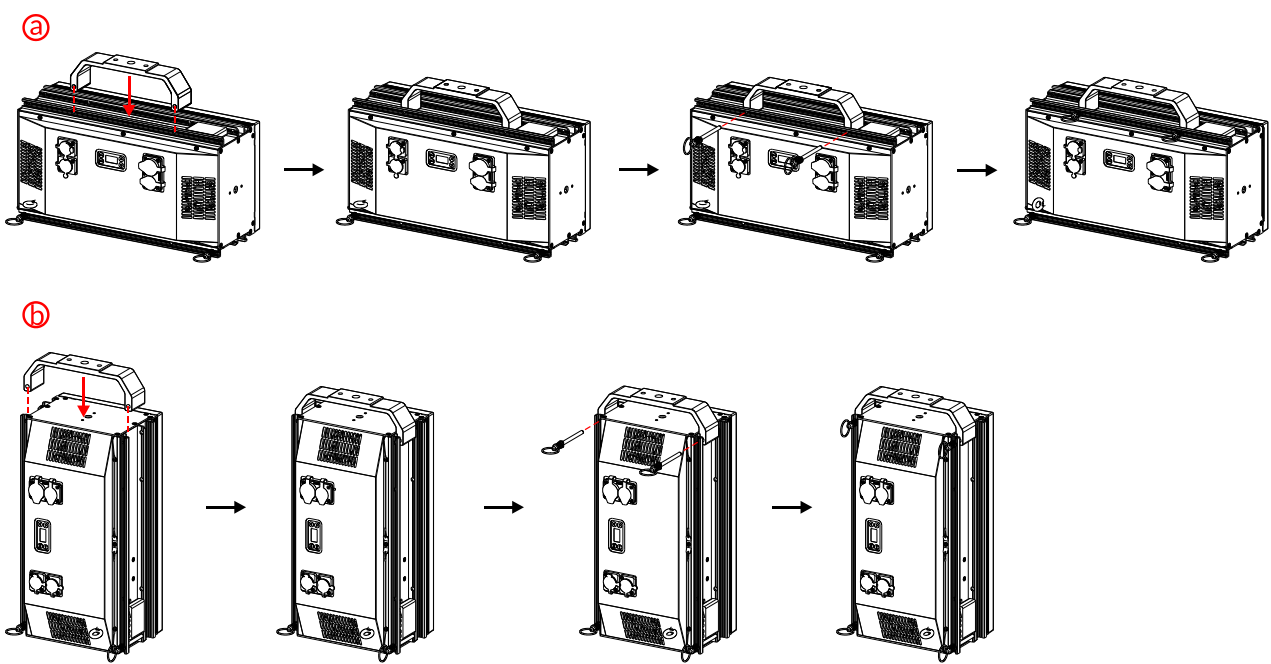

Splicing two fixtures:

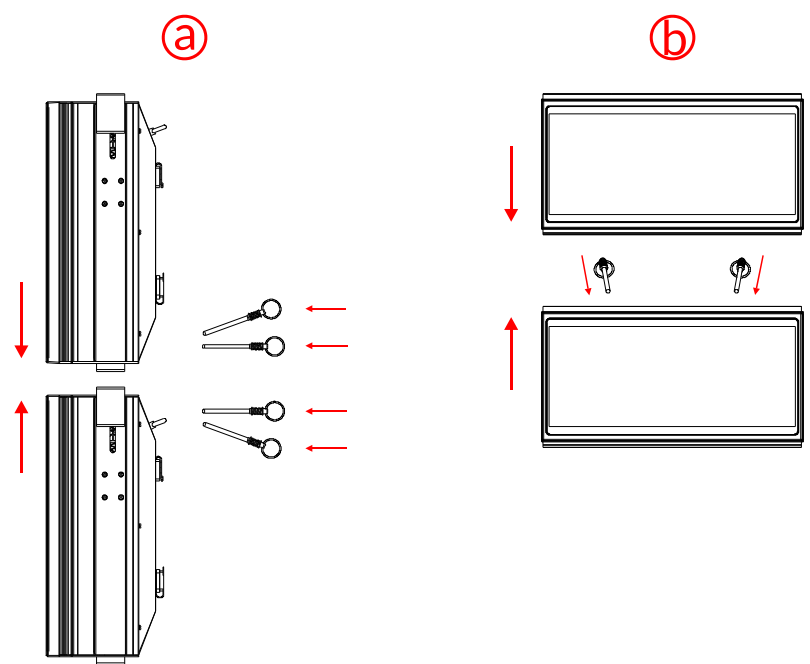

### Installing the big hanging bracket (optional):

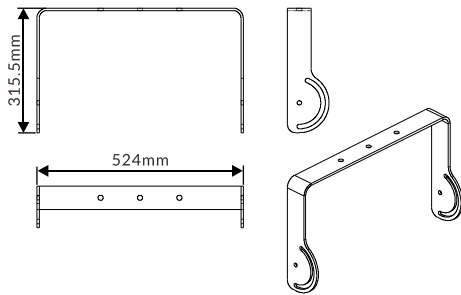

Ⓐ

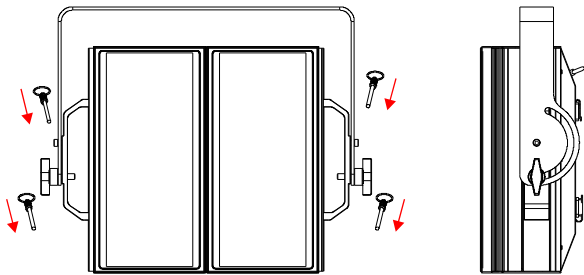

Ⓑ

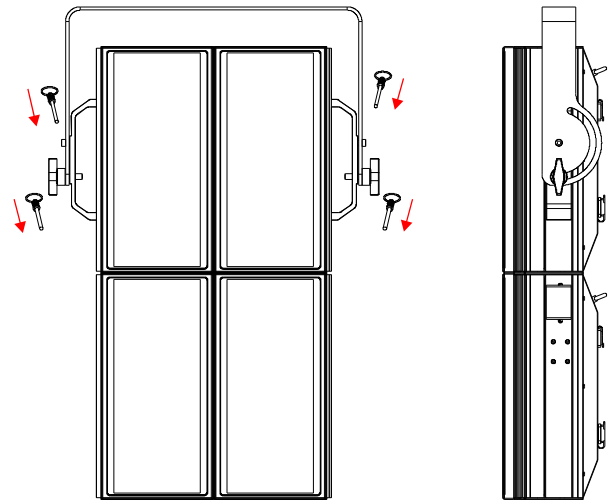

### Splicing multiple fixtures:

Warning: Max. load  $\leq 7$  fixtures vertical.

Ⓐ

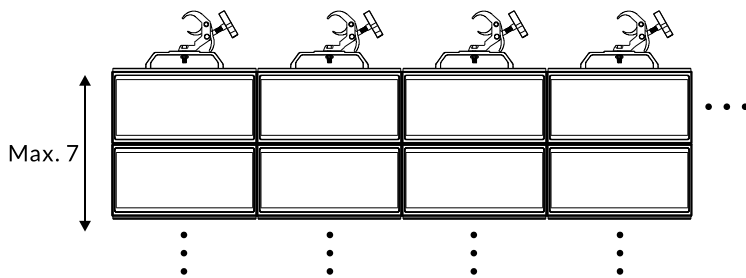

Ⓑ

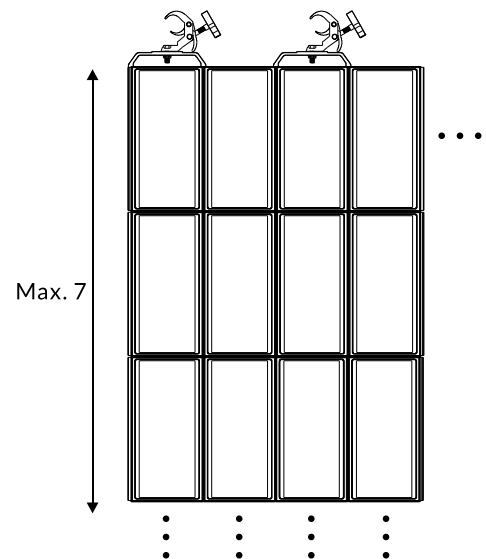

## 05/ How To Set The Unit

### 5.1 Main Functions

- ▶ To access the control menus, press the [MENU] button.
- ▶ Navigate the menu structure, using the [ENTER], [▲ UP] and [▼ DOWN] buttons.
- ▶ To select a menu option or to confirm a selection, press the [ENTER] button.
- ▶ To return to a higher level in the menu structure without making a change, press the [MENU] button, or wait 30 seconds.

The main functions are shown below:

MENU	SUBMENU	OPTIONS		
DMX Settings	DMX Address	1-509 (4 CH 8 bit)	(Default=1)	
		1-505 (8 CH 16 bit)		
		1-505 (8 CH)		
		1-504 (9 CH 16 bit)		
		1-497 (16 CH)		
	Channel Mode	4 Channel. 8 bit		
		8 Channel. 16 bit		
		8 Channel		
		9 Channel. 16 bit		
		16 Channel		
	No DMX Status	Hold		
		Blackout		
		Pri. Sec.		
		Manual		
Fixture Settings	Fan Mode	Auto		
		Silent		
	Dimmer Curve	Linear		
		Square Law		
		Inv SQ Law		
		S Curve		
	Dimmer Speed	Fast		
		Smooth		

MENU	SUBMENU	OPTIONS		
	White Balance	Red	125-255	
		Green	125-255	
		Blue	125-255	
		Red 1	125-255	
		Green 1	125-255	
		Blue 1	125-255	
		Red 2	125-255	
		Green 2	125-255	
		Blue 2	125-255	
		Red 3	125-255	
		Green 3	125-255	
	Blue 3	125-255		
	Pri/Sec Mode	Secondary		
Primary				
Display Settings	Display Invert	Off		
		On		
	Temperature Unit	°C		
		°F		
	Display Warning	Off		
		On		
	Language	English		
		Chinese		
Auto Test				
Manual Test	Red	0-255		
	Green	0-255		
	Blue	0-255		
	White	0-255		
	Intensity	0-255		
	Duration	0-255		
	Rate	0-255		
	Effect	0-255		
Show Program	Set Scene Totals	0-50		
	Edit Scene Color	1-50	Red	0-255
			Green	0-255
			Blue	0-255
			White	0-255
	Fade Time	0-255		
Hold Time	0-255			

MENU	SUBMENU	OPTIONS
Information	Temperature	CPU
		LED 1
		LED 2
		LED 3
	Fan State	
	Fixture Use Hour	
	LED Use Time	
	Firmware Version	
Factory Restore	No	
	Yes	

### DMX Settings

Enter the control menu and select **DMX Settings**, press ENTER. Use the UP/DOWN button to select **DMX Address**, **Channel Mode** or **No DMX Status**.

### DMX Address

Select **DMX Address**, press ENTER.

Use UP/DOWN button to select an address, confirm your selection with ENTER.

CHANNEL MODE	DMX ADDRESS
4 Channel. 8 bit	1-509
8 Channel. 16 bit	1-505
8 Channel	1-505
9 Channel. 16 bit	1-504
16 Channel	1-497

To exit the menu, press MENU, or wait 30 seconds.

### Channel Mode

Select **Channel Mode**, press ENTER.

Use UP/DOWN button to select between **4 Channel. 8 bit**, **8 Channel. 16 bit**, **8 Channel**, **9 Channel. 16 bit** and **16 Channel**, confirm your selection with ENTER.

To exit the menu, press MENU, or wait 30 seconds.

## No DMX Status

Select **No DMX Status**, press ENTER.

Use UP/DOWN button to select one of the following status:

**Hold** (The device continues to operate in the current mode with the last active DMX values until the signal returns)

**Blackout** (Fixture blacks out if DMX signal stops)

**Pri. Sec.** (Primary/Secondary Mode)

**Manual** (The device accepts the DMX value stored in the 'Manual Test' menu)

Confirm your selection with ENTER.

To exit the menu, press MENU, or wait 30 seconds.

## Fixture Settings

Enter the control menu and select **Fixture Settings**, press ENTER. Use the UP/DOWN button to select **Fan Mode**, **Dimmer Curve**, **Dimmer Speed**, **White Balance** or **Pri/Sec Mode**.

## Fan Mode

Select **Fan Mode**, press ENTER.

Use UP/DOWN button to select **Auto** or **Silent**, confirm your selection with ENTER.

To exit the menu, press MENU, or wait 30 seconds.



## Dimmer Curve

Select **Dimmer Curve**, press ENTER.

Use UP/DOWN button to select **Linear**, **Square Law**, **Inv SQ Law** or **S Curve**, confirm your selection with ENTER.

### Dimmer Modes

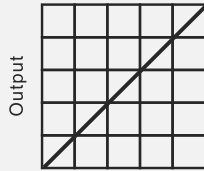

Optically Linear

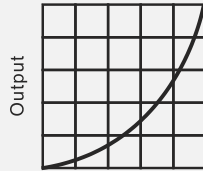

Square Law

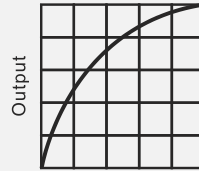

Inverse Square Law

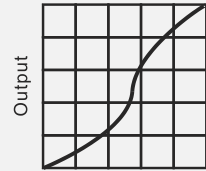

S-curve

To exit the menu, press MENU, or wait 30 seconds.

## Dimmer Speed

Select **Dimmer Speed**, press ENTER.

Use UP/DOWN button to select **Fast** or **Smooth**, confirm your selection with ENTER.

To exit the menu, press MENU, or wait 30 seconds.

## White Balance

Select **White Balance**, press ENTER.

Use UP/DOWN button to select **Red**, **Green**, **Blue**, **Red 1**, **Green 1**, **Blue 1**, **Red 2**, **Green 2**, **Blue 2** or **Red 3**, **Green 3**, **Blue 3**, confirm your selection with ENTER.

Use UP/DOWN button to select a value between **125** and **255**, confirm your selection with ENTER.

To exit the menu, press MENU, or wait 30 seconds.

## Pri/Sec Mode

Select **Pri/Sec Mode**, press ENTER.

Use UP/DOWN button to select **Secondary** or **Primary**, confirm your selection with ENTER.

To exit the menu, press MENU, or wait 30 seconds.

## Display Settings

Enter the control menu and select **Display Settings**, press ENTER. Use the UP/DOWN button to select **Display Invert**, **Temperature Unit**, **Display Warning** or **Language**.

### Display Invert

Select **Display Invert**, press ENTER.

Use UP/DOWN button to select **Off** (display normal) or **On** (display inverted), confirm your selection with ENTER.

To exit the menu, press MENU, or wait 30 seconds.

### Temperature Unit

Select **Temperature Unit**, press ENTER.

Use UP/DOWN button to select **°C** or **°F**, confirm your selection with ENTER.

To exit the menu, press MENU, or wait 30 seconds.

### Display Warning

Select **Display Warning**, press ENTER.

Use UP/DOWN button to select **Off** or **On**, confirm your selection with ENTER.

To exit the menu, press MENU, or wait 30 seconds.

### Language

Select **Language**, press ENTER.

Use UP/DOWN button to select **English** or **Chinese**, confirm your selection with ENTER.

To exit the menu, press MENU, or wait 30 seconds.

### Auto Test

Select **Auto Test**, press ENTER.

The device immediately performs an automatic self-test.

To end the automatic self-test and exit the menu, press MENU, or wait 30 seconds.

## Manual Test

Select **Manual Test**, press ENTER.

Use UP/DOWN button to select the channel for which the manual test is to be performed, confirm your selection with ENTER.

Use UP/DOWN button to select a value, confirm your selection with ENTER.

To exit the menu, press MENU, or wait 30 seconds.

(The device returns to its original DMX state after the manual test. The test values are saved automatically when the device is switched off.)

## Show Program

Enter the control menu and select **Show Program**, press ENTER. Use the UP/DOWN button to select **Set Scene Totals**, **Edit Scene Color**, **Fade Time** or **Hold Time**.

## Set Scene Totals

Select **Set Scene Totals**, press ENTER.

Use UP/DOWN button to select a value between **0** and **50**, confirm your selection with ENTER.

To exit the menu, press MENU, or wait 30 seconds.

## Edit Scene Color

Select **Edit Scene Color**, press ENTER.

Use UP/DOWN button to select a value between **1** and **50**, confirm your selection with ENTER.

Use UP/DOWN button to select **Red**, **Green**, **Blue** or **White**, confirm your selection with ENTER.

Use UP/DOWN button to select a value between **0** and **255**, confirm your selection with ENTER.

To exit the menu, press MENU, or wait 30 seconds.

## Fade Time

Select **Fade Time**, press ENTER.

Use UP/DOWN button to select a value between **0** and **255**, confirm your selection with ENTER.

To exit the menu, press MENU, or wait 30 seconds.

## Hold Time

Select **Hold Time**, press ENTER.

Use UP/DOWN button to select a value between **0** and **255**, confirm your selection with ENTER.

To exit the menu, press MENU, or wait 30 seconds.

## Information

Enter the control menu and select **Information**, press ENTER. Use the UP/DOWN button to select **Temperature**, **Fan State**, **Fixture Use Hour**, **LED Use Time** or **Firmware Version**.

## Temperature

Select **Temperature**, press ENTER.

The device temperature is displayed.

To exit the menu, press MENU, or wait 30 seconds.

## Fan State

Select **Fan State**, press ENTER.

The fan status is displayed.

To exit the menu, press MENU, or wait 30 seconds.

## Fixture Use Hour

Select **Fixture Use Hour**, press ENTER.

The operating hours is displayed.

To exit the menu, press MENU, or wait 30 seconds.

## LED Use Time

Select **LED Use Time**, press ENTER.

The LED operating hours is displayed.

To exit the menu, press MENU, or wait 30 seconds.

## Firmware Version

Select **Firmware Version**, press ENTER.

The firmware version is displayed.

To exit the menu, press MENU, or wait 30 seconds.

## Factory Restore

Select **Factory Restore**, press ENTER.

If you wish to reset the device to the factory settings, select **Yes**. If you do not wish to reset anything, select **No**. Confirm your selection with ENTER.

To exit the menu, press MENU, or wait 30 seconds.

**RDM functions: Certain menus of the device and functions can be called up via the RDM protocol.**

The parameter IDs are implemented as follows for different commands:

Parameter ID	Command 'Discovery'	Command 'Set'	Command 'Get'
DISC_UNIQUE_BRANCH	√		
DISC_MUTE	√		
DISC_UN_MUTE	√		
DEVICE_INFO			√
SUPPORTED_PARAMETERS			√
SOFTWARE_VERSION_LABEL			√
DMX_START_ADDRESS		√	√
IDENTIFY_DEVICE		√	√
DEVICE_MODEL_DESCRIPTION			√
PARAMETER_DESCRIPTION			√
MANUFACTURER_LABEL			√
DEVICE_LABEL		√	√
FACTORY_DEFAULTS		√	√
BOOT_SOFTWARE_VERSION_ID			√
BOOT_SOFTWARE_VERSION_LABEL			√
DMX_PERSONALITY		√	√
DMX_PERSONALITY_DESCRIPTION			√
SLOT_INFO			√
SLOT_DESCRIPTION			√
SENSOR_DEFINITION			√
SENSOR_VALUE			√
DEVICE_HOURS			√
RESET_DEVICE		√	

√ -Command implemented for the respective parameter ID

## 5.2 Home Position Adjustment

- ▶ To access the control menus, press the [MENU] button.
- ▶ To access the offset menus, long-press the [ENTER] button.
- ▶ Navigate the offset menus, using the [ENTER], [▲ UP] and [▼ DOWN] buttons.
- ▶ To select a menu option or to confirm a selection, press the [ENTER] button.
- ▶ To return to a higher level in the menu structure without making a change, press the [MENU] button, or wait 30 seconds.

OFFSET MENU	VALUES
Red 1	0~1000
Red 2	0~1000
Red 3	0~1000
Green 1	0~1000
Green 2	0~1000
Green 3	0~1000
Blue 1	0~1000
Blue 2	0~1000
Blue 3	0~1000
White 1	0~1000
White 2	0~1000
White 3	0~1000
Red	0~1000
Green	0~1000
Blue	0~1000
White	0~1000

### Red 1

Select **Red 1**, press ENTER.

Use UP/DOWN button to select a value between 0 and 1000, confirm your selection with ENTER.

To exit the offset menu, press MENU, or wait 30 seconds.

## Red 2

Select **Red 2**, press ENTER.

Use UP/DOWN button to select a value between 0 and 1000, confirm your selection with ENTER.

To exit the offset menu, press MENU, or wait 30 seconds.

## Red 3

Select **Red 3**, press ENTER.

Use UP/DOWN button to select a value between 0 and 1000, confirm your selection with ENTER.

To exit the offset menu, press MENU, or wait 30 seconds.

## Green 1

Select **Green 1**, press ENTER.

Use UP/DOWN button to select a value between 0 and 1000, confirm your selection with ENTER.

To exit the offset menu, press MENU, or wait 30 seconds.

## Green 2

Select **Green 2**, press ENTER.

Use UP/DOWN button to select a value between 0 and 1000, confirm your selection with ENTER.

To exit the offset menu, press MENU, or wait 30 seconds.

## Green 3

Select **Green 3**, press ENTER.

Use UP/DOWN button to select a value between 0 and 1000, confirm your selection with ENTER.

To exit the offset menu, press MENU, or wait 30 seconds.



## Blue 1

Select **Blue 1**, press ENTER.

Use UP/DOWN button to select a value between 0 and 1000, confirm your selection with ENTER.

To exit the offset menu, press MENU, or wait 30 seconds.

## Blue 2

Select **Blue 2**, press ENTER.

Use UP/DOWN button to select a value between 0 and 1000, confirm your selection with ENTER.

To exit the offset menu, press MENU, or wait 30 seconds.

## Blue 3

Select **Blue 3**, press ENTER.

Use UP/DOWN button to select a value between 0 and 1000, confirm your selection with ENTER.

To exit the offset menu, press MENU, or wait 30 seconds.

## White 1

Select **White 1**, press ENTER.

Use UP/DOWN button to select a value between 0 and 1000, confirm your selection with ENTER.

To exit the offset menu, press MENU, or wait 30 seconds.

## White 2

Select **White 2**, press ENTER.

Use UP/DOWN button to select a value between 0 and 1000, confirm your selection with ENTER.

To exit the offset menu, press MENU, or wait 30 seconds.

### White 3

Select **White 3**, press ENTER.

Use UP/DOWN button to select a value between 0 and 1000, confirm your selection with ENTER.

To exit the offset menu, press MENU, or wait 30 seconds.

### Red

Select **Red**, press ENTER.

Use UP/DOWN button to select a value between 0 and 1000, confirm your selection with ENTER.

To exit the offset menu, press MENU, or wait 30 seconds.

### Green

Select **Green**, press ENTER.

Use UP/DOWN button to select a value between 0 and 1000, confirm your selection with ENTER.

To exit the offset menu, press MENU, or wait 30 seconds.

### Blue

Select **Blue**, press ENTER.

Use UP/DOWN button to select a value between 0 and 1000, confirm your selection with ENTER.

To exit the offset menu, press MENU, or wait 30 seconds.

### White

Select **White**, press ENTER.

Use UP/DOWN button to select a value between 0 and 1000, confirm your selection with ENTER.

To exit the offset menu, press MENU, or wait 30 seconds.

### 6.1 DMX512 Connection

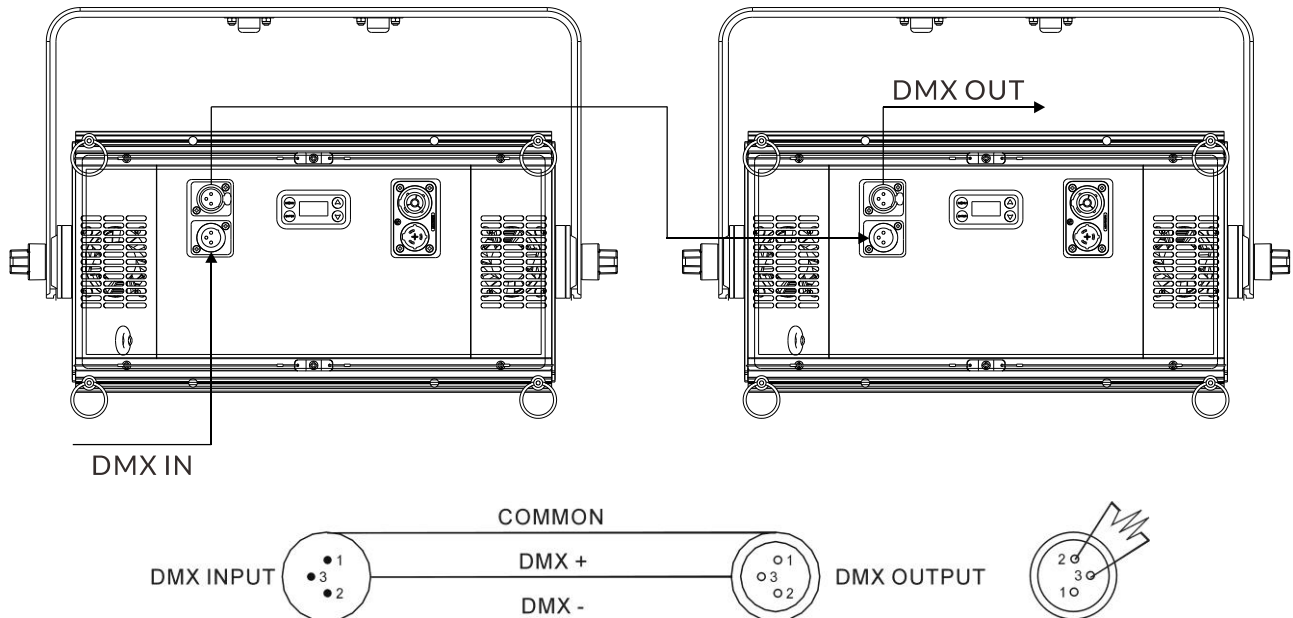

1. At last unit, the DMX cable has to be terminated with a terminator. Solder a 120-ohm 1/4W resistor between pin 2(DMX-) and pin 3(DMX+) into a 3-pin XLR-plug and plug it in the DMX-output of the last unit.
2. Connect the unit together in a “daisy chain” by XLR plug cable from the output of the unit to the input of the next unit. The cable can only be used in series and cannot be connected in parallel. DMX 512 is a very high-speed signal. Inadequate or damaged cables, soldered joints or corroded connectors can easily distort the signal and shut down the system.
3. The DMX output and input connectors are pass-through to maintain the DMX circuit, when one of the units' power is disconnected.
4. Each lighting unit needs to have a DMX address to receive the data by the controller. The address number is between 1-512.
5. The end of the DMX 512 system should be terminated to reduce signal errors.
6. 3 pin XLR connectors are more popular than 5 pins XLR.
  - 3 pin XLR: Pin 1: GND, Pin 2: Negative signal (-), Pin 3: Positive signal (+)
  - 5 pin XLR: Pin 1: GND, Pin 2: Negative signal (-), Pin 3: Positive signal (+), Pin4, Pin5 not used.

## 6.2 Address Setting

If you use a universal DMX controller to control the units, you have to set DMX address between 1 and 512 so that the units can receive DMX signal.

Press the MENU button to access the control menus, select DMX Settings, press the ENTER button to confirm. Use the UP/DOWN button to select DMX Address, press the ENTER button to confirm, the present address will show on the display. Use the UP/DOWN button to adjust the address between 001 and 512, press the ENTER button to store. To exit the menu, press MENU, or wait 30 seconds.

Please refer to the following diagram to address your DMX512 channel for the first 4 units.

Channel Mode	Unit 1 Address	Unit 2 Address	Unit 3 Address	Unit 4 Address
4 Channel. 8 bit	1	5	9	13
8 Channel. 16 bit	1	9	17	25
8 Channel	1	9	17	25
9 Channel. 16 bit	1	10	19	28
16 Channel	1	17	33	59

## 6.3 DMX512 Configuration

Please control the fixture by referring to the configurations below.

### Attentions:

- ▶ The unit will maintain the last condition until reset if you cut-off the DMX signal.
- ▶ For the channel Function, keep the value for about 3 seconds, then the corresponding function will take into effect.

#### 4 Channel. 8 bit (Mode 1):

CHANNEL	VALUE	FUNCTION
1	000-255	RED 0%→100%
2	000-255	GREEN 0%→100%
3	000-255	BLUE 0%→100%
4	000-255	WHITE 0%→100%

#### 8 Channel. 16 bit (Mode 2):

CHANNEL	VALUE	FUNCTION
1	000-255	RED 0%→100%
2	000-255	RED FINE
3	000-255	GREEN 0%→100%
4	000-255	GREEN FINE
5	000-255	BLUE 0%→100%
6	000-255	BLUE FINE
7	000-255	WHITE 0%→100%
8	000-255	WHITE FINE

#### 8 Channel (Mode 3):

CHANNEL	VALUE	FUNCTION
1	000-255	RED 0%→100%
2	000-255	GREEN 0%→100%
3	000-255	BLUE 0%→100%
4	000-255	WHITE 0%→100%
5	000-255	DIMMER 0%→100%

6	000-255	<b>STROBE DURATION</b> 0%→100%
7	000-006 007-255	<b>STROBE RATE</b> Blackout Strobe from Slow to Fast
8	000-005 006-050 051-100 101-150 151-200 201-255	<b>STROBE EFFECT</b> Null Ramp up Ramp down Ramp up-down Lightning Random

9 Channel. 16 bit (Mode 4):

CHANNEL	VALUE	FUNCTION
1	000-255	<b>RED</b> 0%→100%
2	000-255	<b>RED FINE</b>
3	000-255	<b>GREEN</b> 0%→100%
4	000-255	<b>GREEN FINE</b>
5	000-255	<b>BLUE</b> 0%→100%
6	000-255	<b>BLUE FINE</b>
7	000-255	<b>WHITE</b> 0%→100%
8	000-255	<b>WHITE FINE</b>
9	000 001-004 005-009 010-013 014-018 019-022 023-027 028-031 032-036 037-040 041-045 046-049 050-054 055-058	<b>LINEAR CTO(8000K-2500K)</b> Null 8000K 7900K 7800K 7700K 7600K 7500K 7400K 7300K 7200K 7100K 7000K 6900K 6800K

059-063	6700K
064-067	6600K
068-072	6500K
073-076	6400K
077-081	6300K
082-085	6200K
086-090	6100K
091-094	6000K
095-099	5900K
100-103	5800K
104-108	5700K
109-112	5600K
113-117	5500K
118-121	5400K
122-126	5300K
127-130	5200K
131-135	5100K
136-139	5000K
140-144	4900K
145-148	4800K
149-153	4700K
154-157	4600K
158-162	4500K
163-166	4400K
167-171	4300K
172-175	4200K
176-180	4100K
181-184	4000K
185-189	3900K
190-193	3800K
194-198	3700K
199-202	3600K
203-207	3500K
208-211	3400K
212-216	3300K
217-220	3200K
221-225	3100K
226-229	3000K
230-234	2900K
235-238	2800K
239-243	2700K
244-247	2600K
248-255	2500K

16 Channel (Mode 5):

CHANNEL	VALUE	FUNCTION
1	000-255	<b>RED 1</b> 0%→100%
2	000-255	<b>GREEN 1</b> 0%→100%
3	000-255	<b>BLUE 1</b> 0%→100%
4	000-255	<b>WHITE 1</b> 0%→100%
5	000-255	<b>RED 2</b> 0%→100%
6	000-255	<b>GREEN 2</b> 0%→100%
7	000-255	<b>BLUE 2</b> 0%→100%
8	000-255	<b>WHITE 2</b> 0%→100%
9	000-255	<b>RED 3</b> 0%→100%
10	000-255	<b>GREEN 3</b> 0%→100%
11	000-255	<b>BLUE 3</b> 0%→100%
12	000-255	<b>WHITE 3</b> 0%→100%
13	000-255	<b>DIMMER</b> 0%→100%
14	000-255	<b>STROBE DURATION</b> 0%→100%
15	000-006 007-255	<b>STROBE RATE</b> Blackout Strobe from Slow to Fast
16	000-005 006-050 051-100 101-150 151-200 201-255	<b>STROBE EFFECT</b> Null Ramp up Ramp down Ramp up-down Lightning Random



## 07/ Error Information

Error codes are shown continuously in the display when the fixture fails and they will not disappear until the fixture is repaired.

### CPU-B Error

Check whether the 485 (DATA) leads on the PCB board are installed in place or disconnected.

Check whether the related 485 (DATA) signal circuit on the PCB board is damaged.

### Fan3 can't start

Check whether the fan is not running.

Check whether the fan leads are installed in place or disconnected.

Check whether the fan is damaged.

Check whether there are obstacles in the fan operating range.

### Fan3 can't stop

Check whether the fan circuit on the motherboard breaks down.

Check whether the component is damaged.

### Fan3 speed too fast

Check whether the fan is out of order.

Check whether the fan circuit on the motherboard breaks down.

### Fan3 speed too slow

Check whether the fan is out of order.

Check whether there are obstacles in the fan operating range.

The position of each fan of the fixture:

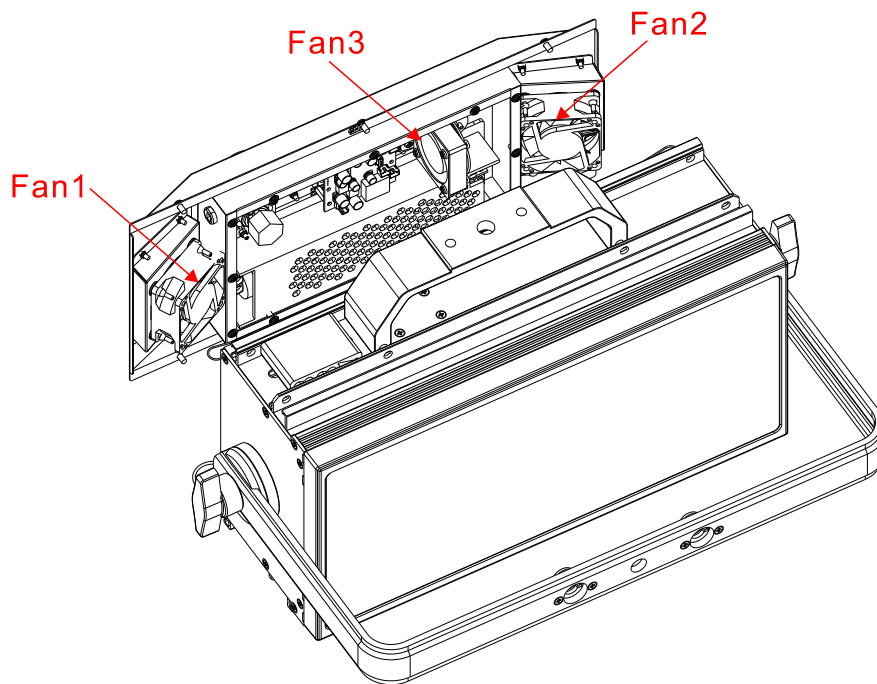

---

## 08/ Troubleshooting

Following are a few common problems that may occur during operation. Here are some suggestions for troubleshooting:

**A. The unit does not work, no light and the fan does not work**

- ▶ Check the connected power.
- ▶ Measure the voltage.
- ▶ Check the power indicator to see whether it can be lit up or not.

**B. Not responding to the DMX controller**

- ▶ Check whether the DMX connectors and the DMX cables are connected correctly.
- ▶ Check whether the DMX address is correctly set.
- ▶ If the intermittent DMX signal problem occurs, check whether the XLR socket and the signal cable are well connected.
- ▶ Try it with another DMX controller.
- ▶ Check whether the DMX cables run near or alongside to the high-voltage cables, which may damage or interfere with the signal circuit.

## 09/ Fixture Cleaning

---

It is absolutely essential that the fixture is kept clean to ensure the maximum light-output and allow the fixture to function reliably throughout its life. The fixture must be cleaned regularly to avoid dust, dirt and smoke-fluid residues building up on or within the fixture. The cleaning frequency depends on the application environment. Clean the fixture immediately if the dust enters it to avoid damage to the optical lens due to excessive dust.

- ▶ A soft lint-free cloth moistened with any good glass cleaning fluid is recommended, under no circumstances should solvents be used.
- ▶ Always dry the parts carefully.
- ▶ Clean the external optical lens at least every 20 days.

### **Declaration of Conformity**

We declare that our products (lighting equipments) comply with the following specification and bears CE mark in accordance with the provision of the Electromagnetic Compatibility (EMC) Directive 2014/30/EU.

EN 55032: 2015; EN IEC 61000-3-2: 2019;  
EN 61000-3-3: 2013; EN 55035: 2017.

### **& Harmonized Standard**

EN 60598-1: 2015;  
EN 60598-2-17: 2018; EN 62493: 2015.  
Safety of household and similar electrical appliances  
Part 1: General requirements and tests



---

[www.acme.com.cn](http://www.acme.com.cn)