

Acme®

HYPERZONE

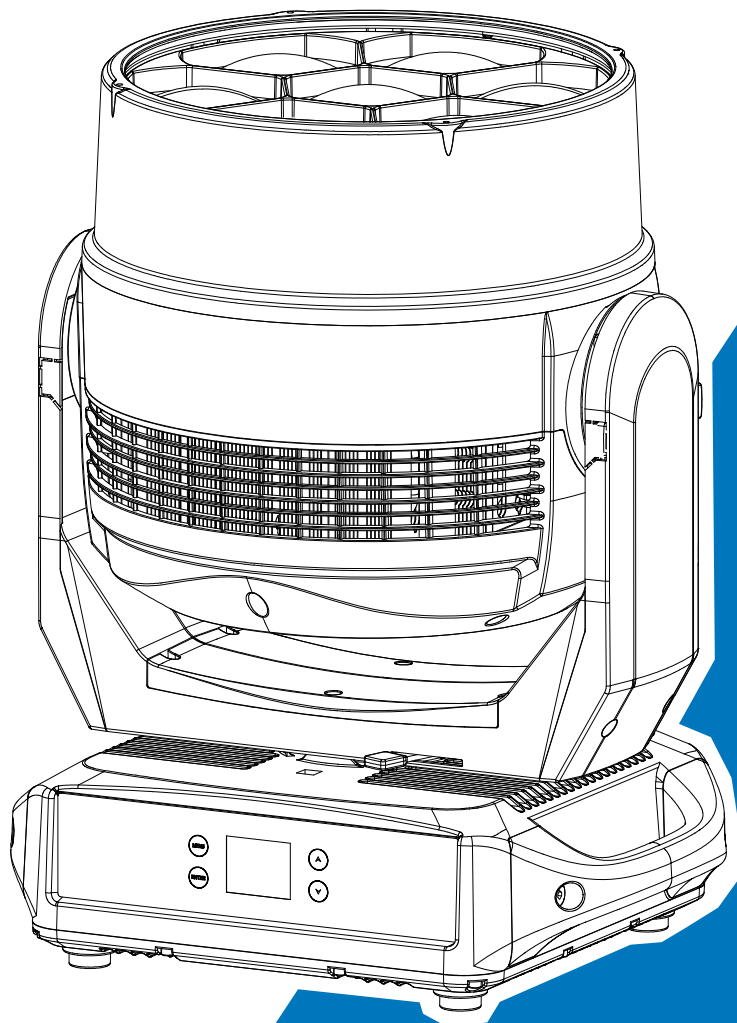

User Manual

Please read the instruction carefully before use

CONTENTS

01/ Safety Information.....	2
02/ Technical Specifications	8
03/ Overview	10
3.1 Battery Power	11
04/ Connecting Power and Data	13
4.1 Connecting Power	13
4.2 Connecting Data	14
05/ Fixture Installation.....	15
06/ Operation	19
6.1 Control Menu.....	19
6.2 Updating Software.....	34
6.3 Home Position Adjustment.....	39
07/ Configuring the Device for DMX Control.....	44
7.1 Address Setting.....	44
7.2 DMX Protocol.....	45
08/ Error Information	51
09/ Troubleshooting.....	56
10/ Fixture Cleaning.....	57
11/ Approvals and Certifications.....	58

01/ Safety Information



Please read the instruction carefully which includes important information about the installation, usage and maintenance.

WARNING

Please keep this User Manual for future consultation. If you sell the fixture to another user, be sure that they also receive this instruction manual.

Important:

Damages caused by the disregard of this user manual are not subject to warranty. The dealer will not accept liability for any resulting defects or problems.

- Unpack and check carefully to ensure that there is no transportation damage before using the fixture.
- This product is suitable for wet locations. Do not immerse in water.
- DO install and operate by qualified operator.
- DO NOT allow children to operate the fixture.
- Use safety cable when fixing the fixture. Handle the fixture by carrying its base instead of the head only.
- The fixture must be installed in a location with adequate ventilation, at least 50cm from adjacent surfaces.
- Be sure that no ventilation holes are blocked, otherwise the fixture could over heat.
- Before operation, ensure that you are connecting this product to the proper voltage in accordance with the specifications in this manual or on the product's specification label.
- It's important to ground the yellow/green conductor to earth in order to avoid electric shock.
- Minimum ambient temperature TA: -10°C. Maximum ambient temperature TA: 40°C. Do not operate this product at a lower or higher temperature.
- DO NOT connect the device to any dimmer pack.
- Keep flammable materials away from the fixture while operating to avoid fire hazard.
- Make sure the power cord is not crimped or damaged; replace it immediately if damaged.
- Fixture's surface temperature may reach up to 65°C. DO NOT touch the housing bare-handed during its operation.

- Avoid any flammable liquids, water or metal from entering the fixture. If it happens, cut off the mains power immediately.
- DO NOT operate in a dirty or dusty environment. DO clean the fixture regularly.
- DO NOT touch any wiring during operation as there might be a hazard of electric shock.
- Avoid entanglement of the power cord with other wires.
- The minimum distance to objects/surface must be more than 5 meters.
- In the event of a serious operating problem, stop using the fixture immediately.
- Never turn the fixture off and on repeatedly.
- The housing, the lenses, or the ultraviolet filter must be replaced if they are visibly damaged.
- DO NOT open the housing as there are no user serviceable parts inside.
- DO NOT attempt to operate this fixture if it becomes damaged. DO NOT attempt any repairs yourself. Repairs carried out by unskilled people can lead to damage or malfunction. Please contact the nearest authorized technical assistance center if needed.
- Disconnect this product from its power source before servicing.
- DO use the original packaging or suitable road case if the device is to be transported.
- Check that the head tilt lock is released before packing for transportation.
- Avoid direct eye exposure to the light source while the product is on.
- DO NOT operate this product if you see damage on the housing, shields, or cables. Have the damaged parts replaced by an authorized technician at once.
- The device MUST NOT be switched on immediately if it has been exposed to strong temperature fluctuations (e.g. after transport) as condensation may occur inside. Please leave the device switched off until it has reached ambient temperature.

- External sources of light beams from direct sunlight or any other strong light source, which penetrate the front lens of lighting fixtures, can cause severe internal damage. DO NOT expose the fixture front lens to light beams from direct sunlight or any other strong light source from any angle while unpacking, installation, use, and extended idle times outdoors. DO NOT focus a light beam from one lighting fixture directly towards another.

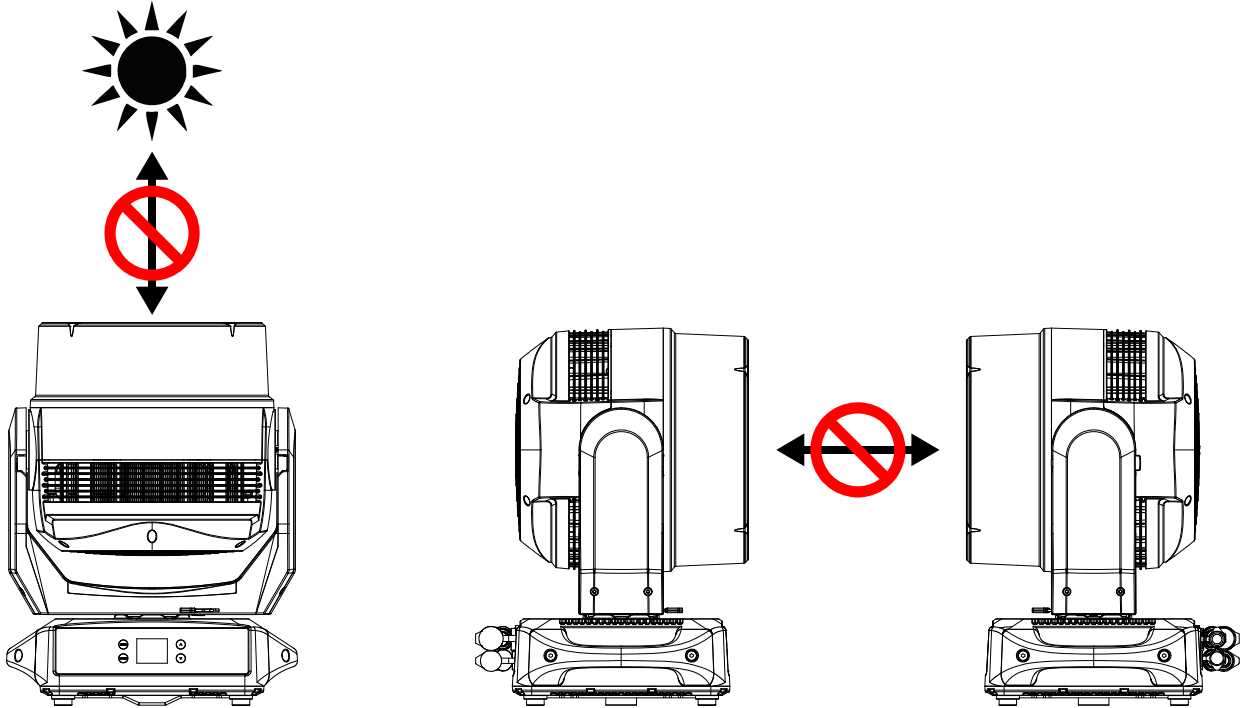

01/ Informations de sécurité



AVERTISSEMENT

Veillez lire attentivement les instructions, car elles contiennent des informations importantes concernant l'installation, l'utilisation et la maintenance.

Veillez conserver ce manuel d'utilisation pour consultation future. Si vous vendez l'appareil à un autre utilisateur, assurez-vous qu'il reçoive également ce manuel d'instructions.

Important:

Les dommages causés par le non-respect de ce manuel d'utilisation ne sont pas couverts par la garantie. Le revendeur n'acceptera aucune responsabilité pour les défauts ou problèmes qui en résulteraient.

- Déballer et vérifier soigneusement qu'il n'y a pas de dommages dus au transport avant d'utiliser l'appareil.
- Ce produit est adapté aux endroits humides. Ne pas immerger dans l'eau.
- FAIRE installer et utiliser par un opérateur qualifié.
- NE PAS laisser les enfants manipuler l'appareil.
- Utiliser une chaîne de sécurité lors de la fixation de l'appareil. Manipuler l'appareil en portant sa base et non uniquement par la tête.
- L'appareil doit être installé dans un endroit bien ventilé, à au moins 50 cm des surfaces adjacentes.
- Assurez-vous qu'aucune fente de ventilation n'est obstruée, sinon l'appareil surchauffera.
- Avant utilisation, assurez-vous de connecter ce produit à la tension appropriée conformément aux spécifications de ce manuel ou à l'étiquette des spécifications du produit.
- Il est important de mettre le conducteur jaune/vert à la terre pour éviter tout risque de choc électrique.
- Température ambiante minimale (TA): -10°C. Température ambiante maximale (TA): 40°C. Ne pas utiliser ce produit à une température inférieure ou supérieure.
- NE PAS connecter l'appareil à un gradateur (dimmer pack).
- Éloigner les matériaux inflammables de l'appareil pendant son fonctionnement pour éviter tout risque d'incendie.

- Vérifier que le cordon d'alimentation n'est ni écrasé ni endommagé; le remplacer immédiatement s'il est endommagé.
- La température de surface de l'appareil peut atteindre jusqu'à 65°C. NE PAS toucher le boîtier à mains nues pendant son fonctionnement.
- Évitez que des liquides inflammables, de l'eau ou des objets métalliques ne pénètrent dans l'appareil. Si cela se produit, coupez immédiatement l'alimentation électrique.
- NE PAS utiliser l'appareil dans un environnement sale ou poussiéreux. Nettoyez régulièrement l'appareil.
- NE PAS toucher de fils pendant le fonctionnement, car cela pourrait présenter un risque de choc électrique.
- Évitez que le cordon d'alimentation ne s'emmêle avec d'autres fils.
- La distance minimale par rapport aux objets/surfaces doit être de plus de 5 mètres.
- En cas de problème de fonctionnement grave, cessez immédiatement d'utiliser l'appareil.
- Ne jamais allumer et éteindre l'appareil à plusieurs reprises.
- Le boîtier, les lentilles ou le filtre ultraviolet doivent être remplacés s'ils sont visiblement endommagés.
- NE PAS ouvrir le boîtier, car il ne contient aucune pièce pouvant être réparée par l'utilisateur.
- NE PAS tenter d'utiliser cet appareil s'il est endommagé. NE PAS tenter de réparations vous-même. Les réparations effectuées par des personnes non qualifiées peuvent entraîner des dommages ou un dysfonctionnement. Veuillez contacter le centre d'assistance technique agréé le plus proche si nécessaire.
- Débranchez l'appareil de sa source d'alimentation avant toute maintenance.
- UTILISEZ l'emballage d'origine si l'appareil doit être transporté.
- Vérifiez que le verrou d'inclinaison de la tête est libéré avant l'emballage pour le transport.
- Évitez une exposition directe des yeux à la source lumineuse lorsque l'appareil est allumé.
- NE PAS utiliser ce produit si vous constatez des dommages sur le boîtier, les protections ou les câbles. Faites remplacer les pièces endommagées par un technicien agréé immédiatement.

- L'appareil NE DOIT PAS être allumé immédiatement s'il a été exposé à de fortes variations de température (par exemple après un transport), car de la condensation pourrait se former à l'intérieur. Veuillez laisser l'appareil éteint jusqu'à ce qu'il ait atteint la température ambiante.
- Les sources externes de rayons lumineux, comme la lumière directe du soleil ou toute autre source lumineuse intense, qui pénètrent à travers la lentille frontale des appareils d'éclairage, peuvent causer des dommages internes graves. NE PAS exposer la lentille frontale de l'appareil à des rayons lumineux provenant de la lumière directe du soleil ou de toute autre source lumineuse intense, sous quelque angle que ce soit, lors du déballage, de l'installation, de l'utilisation ou de périodes d'inactivité prolongées à l'extérieur. NE PAS diriger un faisceau lumineux d'un appareil d'éclairage directement vers un autre.

02/ Technical Specifications

AC Power	100-240Vac; 50/60Hz	
Max. Power Consumption	1370W	
Light Source	7x150W RGBL LED	
Color Temperature	2500K-8000K	
Beam Angle	3°-32°	
Field Angle	4.8°-45°	
Movement	Pan	540°
	Tilt	210°
	16 bit movement resolution	
	Automatic pan/tilt repositioning	
	Mechanical pan/tilt lock for safe transportation and maintenance	
Control and Programming	DMX Channels	19/41/20/42
	Protocols	DMX512
		RDM
		Art-Net
		sACN
Firmware Update	via DMX or USB memory device	
Construction	Display	LCD display
	Battery backup for user setup without mains connection	
	DMX and RDM Data In/Out	5-pin IP XLR (optional with 3-pin IP XLR) RJ45 Connectors
	Power In/Out	Waterproof Power Connector in/out
	Protection Rating	IP66
Dynamic Effects	7 x RGBL LEDs with individual control	
	0-100% continuous dimming and strobe effects	
	Choice of four dimming curves	
	Motorized zoom	
	Variable color temperature control	
	Outstanding color mixing	

Dimensions	380x318x500mm (version with omega bracket holes)	15"x12.5"x19.7"
	380x318x541mm (version with fixed foldable clamps)	15"x12.5"x21.3"
Weight	26.4 kg (version with omega bracket holes)	58.2 lbs
	29.3 kg (version with fixed foldable clamps)	64.6 lbs

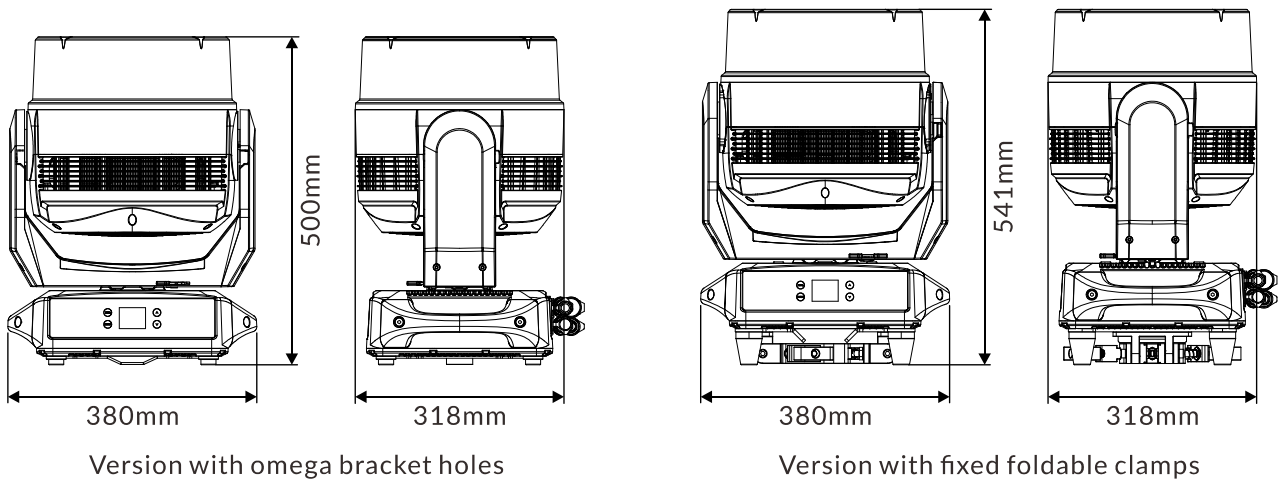

Photometric Diagram (Beam Angle):

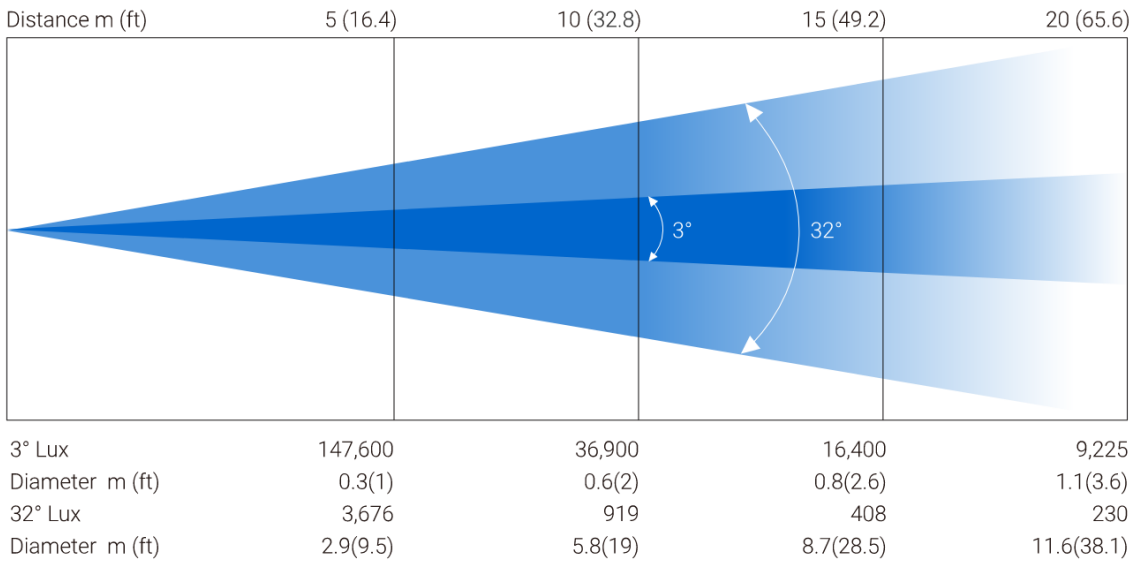

Photometric Diagram (Field Angle):

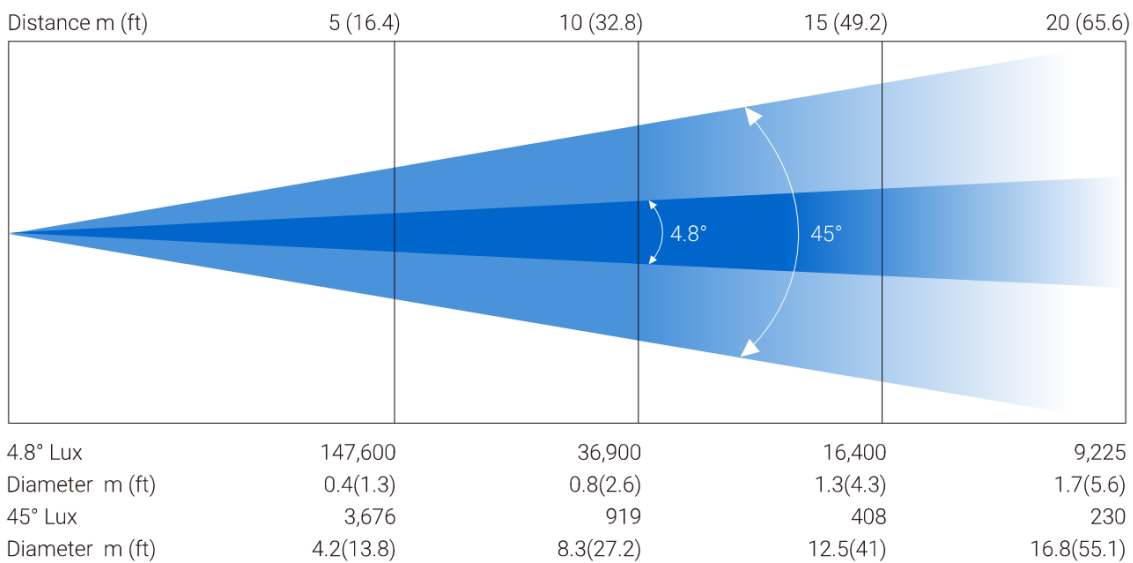

03/ Overview

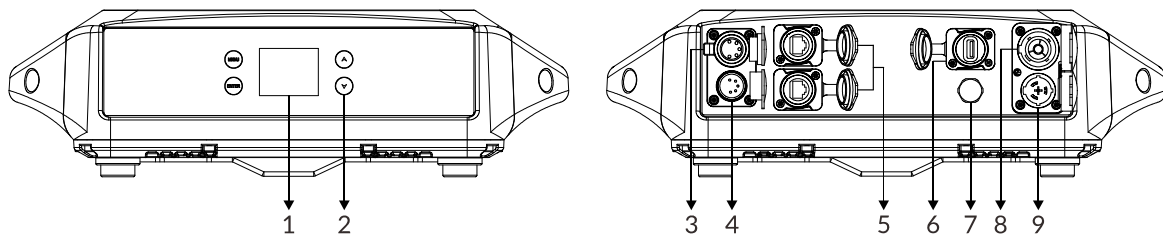

1. Display	To show the various menus and the selected function	
2. Buttons	MENU	To enter into, move backward or leave the menu
	▲ UP	To go backward or move up in the menu
	▼ DOWN	To go forward or move down in the menu
	ENTER	To perform the desired functions
3. DMX OUT	For DMX512 link, use 5-pin IP XLR cable to link the next units to output DMX signal (optional with 3-pin IP XLR)	
4. DMX IN	For DMX512 link, use 5-pin IP XLR cable to link the unit and DMX controller to input DMX signal (optional with 3-pin IP XLR)	
5. ETHERNET	For use with sACN or Art-Net controls	
6. FIRMWARE UPGRADE	Used to upgrade fixture's firmware	
7. RELEASE VALVE		
8. POWER OUT	To connect to the next fixture	
9. POWER IN	To connect to supply power	

3.1 Battery Power

This product contains a rechargeable battery.

Battery type: 14500 Lithium-ion battery (3.7V, 800mAh, 2.96Wh), compliant with the new EU battery regulation EU2023/1542.



Do not expose the fixture or battery to excessive temperatures.

Be aware of the risk of terminals of the battery-operated fixture or battery being short-circuited by metal objects.

This fixture contains battery that is only replaceable by skilled persons.

Different types of batteries or new and used batteries are not to be mixed.

Exhausted batteries are to be removed from the fixture and safely disposed of.

If the fixture is to be stored unused for a long period, the batteries should be removed.

Do not use non-rechargeable batteries in place of rechargeable batteries.

Do not use modified or damaged batteries.

Replacing the battery with an incorrect type can defeat a safeguard and pose a risk of fire or explosion.

Disposal of a battery into fire or a hot oven, or mechanically crushing or cutting of a battery, that can result in an explosion.

Leaving a battery in an extremely high temperature surrounding environment that can result in an explosion or the leakage of flammable liquid or gas.

Using the control panel with battery power:

The fixture contains a battery that enables you to use the control panel to set up the fixture even when it is not connected to the main power supply. The battery charges during fixture operation. All of the main setup options in the control panel are accessible on battery power, but the 'Fixture Test' and 'Reset Function' are not available.

To activate the display when the fixture is not connected to power, press and hold the [▲ UP] button for 3 seconds. The display extinguishes after 30 seconds with no user input. Press and hold the [▲ UP] button for 3 seconds again to re-activate.

Battery Replacement:

Warning! Disconnect the fixture from AC power before replacing its battery. Replace the battery with one of the same type only.

1. Disconnect the fixture from AC mains power and allow to cool.
2. Remove two screws that secure the battery cover at the bottom of the fixture and then remove the battery cover.

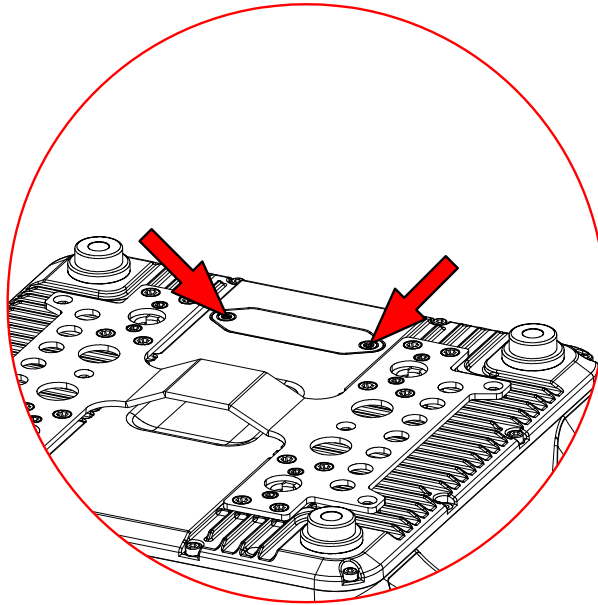

3. Remove the exhausted battery and insert a new one (only the same type) into the battery holder (Negative (-) towards the spring, Positive (+) away from the spring).

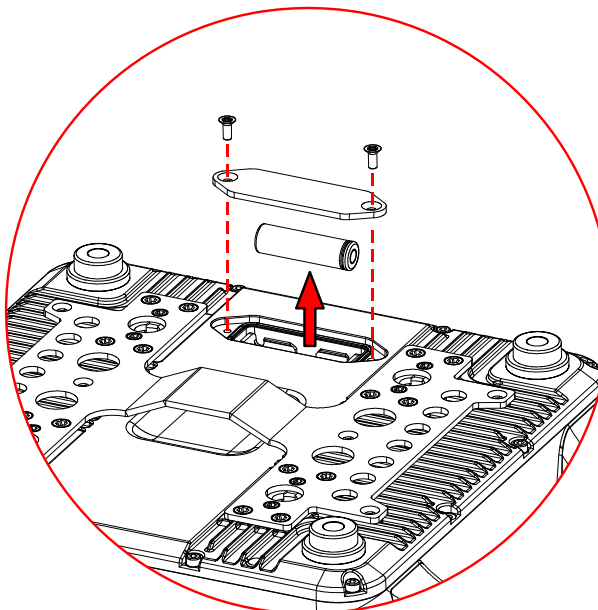

4. Reinstall the battery cover.

04/ Connecting Power and Data

4.1 Connecting Power

To apply power, first check that the head pan and tilt locks are released.

This fixture can operate on any 100-240Vac; 50/60Hz AC mains power supply.

The maximum power consumption is 1370W.

The fixture must be grounded/earthed and able to be isolated from AC power. The AC power supply must incorporate a fuse or circuit breaker for fault protection.

Wiring and connection work must be carried out by a qualified electrician.

The power cable color coding is given in the figure below:

Wire	Color (US)	Wire	Color (EU)	Symbol	Conductor
	black		brown	L	live
	white		blue	N	neutral
	green		yellow/green	\perp or \oplus	ground (earth)

Power cord set should be used: Listed SJOW flexible cord with rating: 300V, 105°C, VW-1, 14AWG x 3C, molded with 5-20P attachment plug and terminated with cord connector model RCAC3F-X-000-01 with rating 250V, 20A by Neutrik Technology (Ningbo) Co., Ltd. The power cord shall be at least 914mm (It is to be measured from the face of attachment plug to the face of connector).

CAUTION!

DO NOT CONNECT THE FIXTURE TO AN ELECTRICAL DIMMER SYSTEM AS DOING SO MAY CAUSE DAMAGE.

4.2 Connecting Data

The fixture is equipped with 5-pin (or 3-pin) XLR sockets for DMX input and output. Use shielded twisted-pair high-quality DMX cable designed for RS-485 fixtures in order to connect the controller with the fixture and one fixture with another. For outdoor installations, use only waterproof DMX cables suitable for outdoor use.

The default pin-out on XLR sockets is as the following diagram:

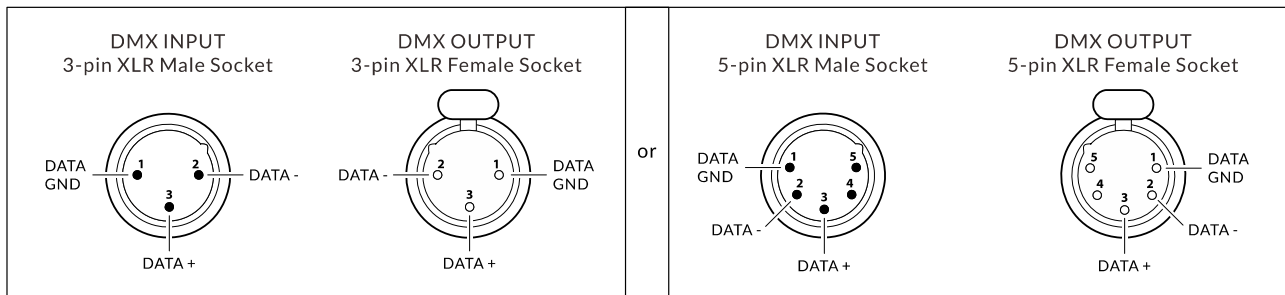

Building a serial DMX chain:

1. Connect the DMX data output from the controller to the fixture's data input socket.
2. Connect the DMX output of the first fixture in the DMX chain with the DMX input of the next fixture. Always connect one output with the input of the next fixture until all fixtures are connected.

Note: Up to 32 fixtures can be connected to the same DMX link.

3. Terminate the DMX output of the last fixture in the data link with a DMX terminator which is an XLR plug with a 120 Ω , 1/4 watt resistor connected between pins 2 and 3.

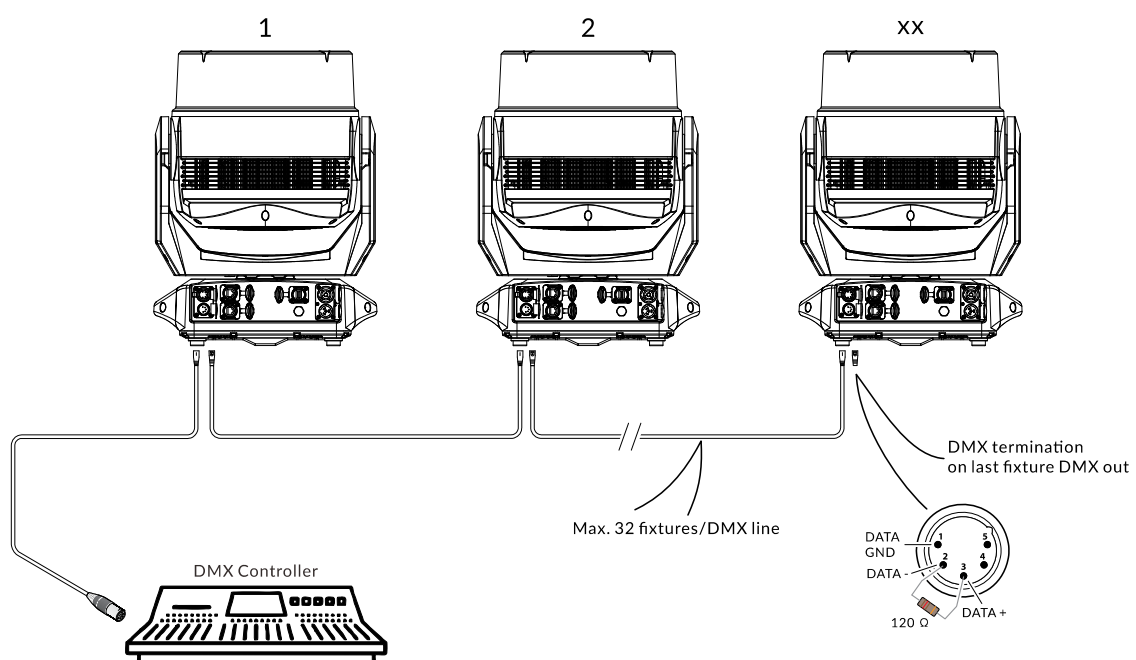

05/ Fixture Installation

The fixture is IP66-rated and designed for both indoor and outdoor events. This means that it is protected from:

- ▶ Dust, to the degree that dust cannot enter the device in sufficient quantities as to interfere with its operation.
- ▶ Water jets from any direction.

DO install and operate by qualified operator. Fixture(s) should be installed in areas clear of walking paths, seating areas, or away from areas where unauthorized personnel might reach the fixture by hand. NEVER stand directly below the fixture(s) when rigging, removing or servicing.

Always ensure that the unit is firmly fixed to avoid vibration and slipping off during operation. Ensure that the trussing or area of installation must be able to hold 10 times the weight without any deformation. Always attach a safety cable that can hold at least 12 times the weight of the fixture whenever installing this fixture in a suspended environment to ensure that the fixture will not fall if the clamp fails.

This fixture is fully operational in three different mounting positions: hanging upside-down, mounted sideways on truss, or base positioned on floor.

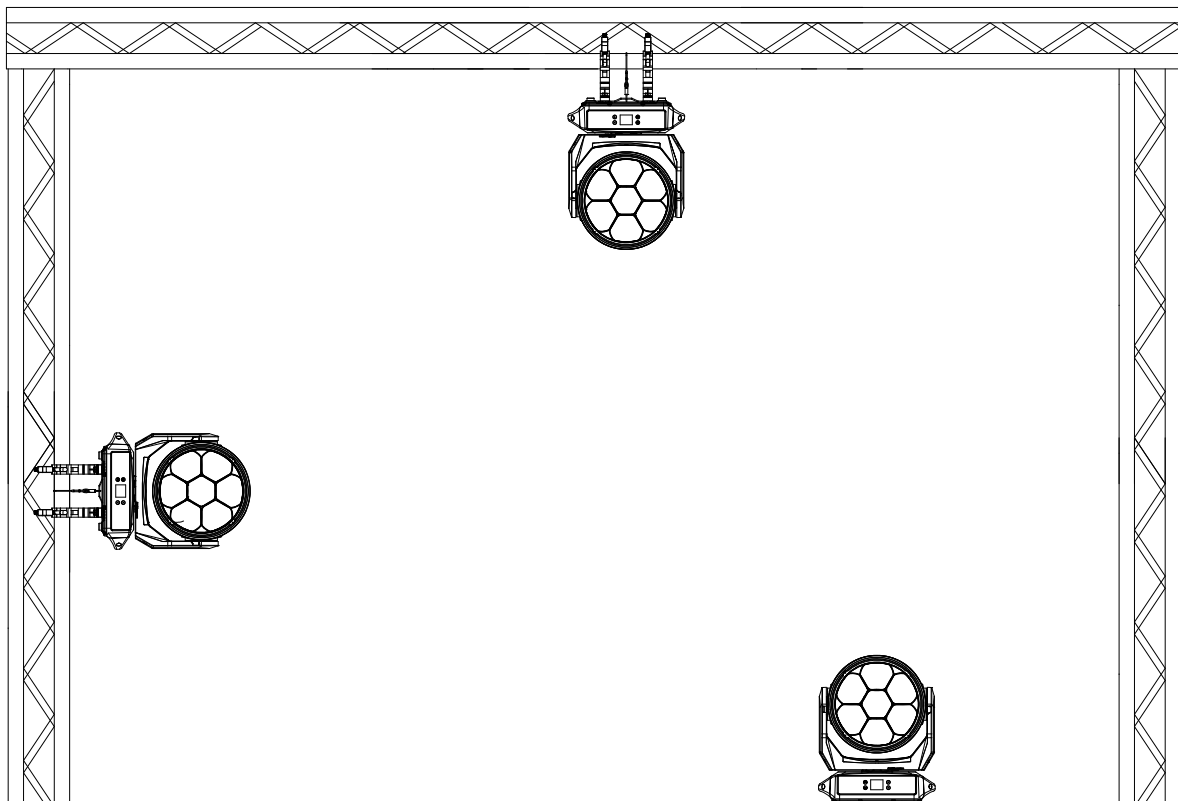

- Use only waterproof power cords and connectors suitable for outdoor use.
- Visually check panel connectors on accidental water leaks and dust before connecting related cable connectors. If some water appears in panel connectors, do not connect cable connectors, especially power!
- Fixtures require regular maintenance. Carefully check panel connectors for corrosion and scorching, and replace them promptly if damaged.
- All power and data connectors are equipped with rubber caps to prevent water ingress. All unused panel connectors have to be sealed by the rubber caps to avoid contact with water, especially seawater.

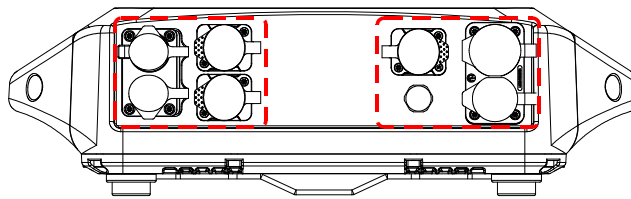

- When routing cables, always bring them into connectors from below. Form a service loop where needed, allowing gravity to divert condensation and water droplets away from the connectors.

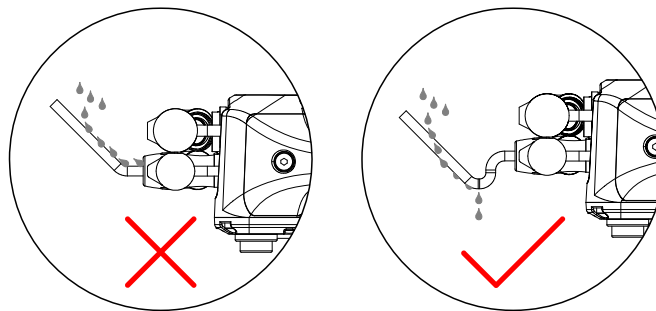

- To ensure the long-term reliable performance of the fixture, it is recommended to perform external cleaning and maintenance every one to two months. Promptly remove corrosive residues such as acidic substances and sea salt deposits attached to the surface of the fixture to slow down the oxidation process of the housing. Additionally, inspect and clean protective grilles and other structures to prevent small organisms like insects from entering the interior, avoiding functional abnormalities or fan blockages caused by the accumulation of insect remains.

- To ensure reliable performance of the fixture in cold environments, it features a built-in preheating program. After powering on, the fixture automatically detects its internal temperature. Fixture reset can be delayed if the detected temperature is below -10°C . This delay is caused by heating fixture to its operating temperature. The fixture does not respond to DMX or Ethernet during heating process. When the operating temperature reaches -10°C or above, the fixture starts up as expected.



Side Mounting:

To maintain the IP66 rating integrity of the fixture, all cables must be run towards the ground to prevent water accumulation around the connections.

System menu
LCD display

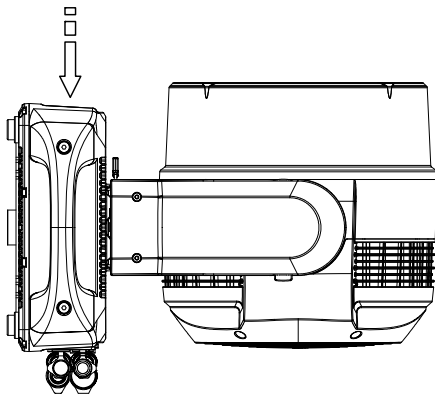

Cables

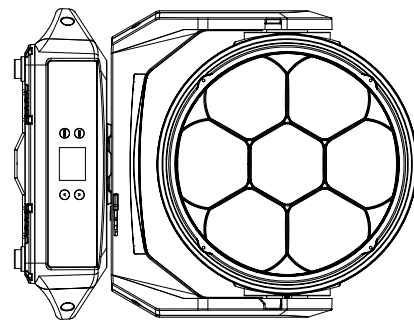

Cables

Steps for installing omega brackets to the fixture:

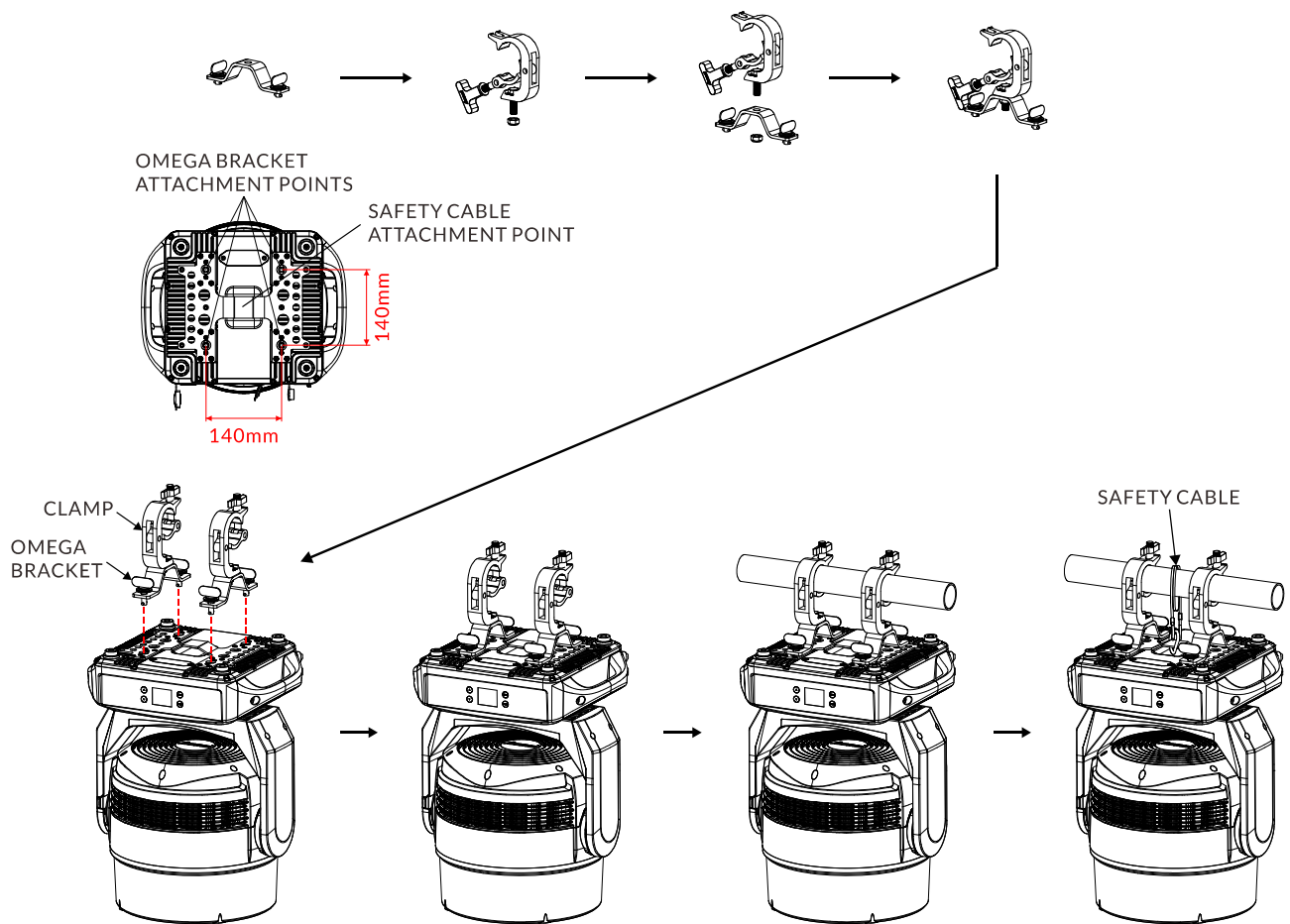

Accessories:

This fixture can be used with different types of accessories such as barndoors, top hat, or concentric rings. Four M4 mounting holes for optional accessories by others are reserved.

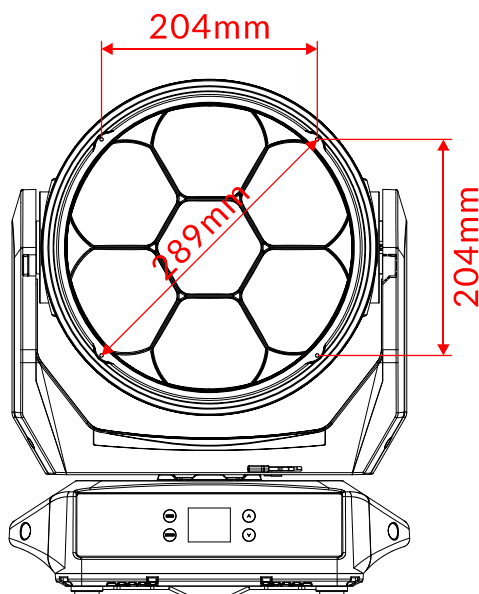

06/ Operation

6.1 Control Menu

- ▶ To access the control menus, press the [MENU] button.
- ▶ Navigate the menu structure, using the [ENTER], [▲ UP] and [▼ DOWN] buttons.
- ▶ To select a menu option or to confirm a selection, press the [ENTER] button.
- ▶ To return to a higher level in the menu structure without making a change, press the [MENU] button, or wait 30 seconds.

The screen locks after 30 seconds of inactivity.
Press and hold the [MENU] button to unlock the screen.

The main functions are shown below:

MAIN MENU	SUBMENU	CHOICES/VALUES		
DMX Settings	DMX Address	001-512	(Default=1)	
	DMX Channel Mode	Mode 1 (19)		
		Mode 2 (41)		
		Mode 3 (20)		
		Mode 4 (42)		
	No DMX Status	Blackout		
		Hold		
		Manual		
	View DMX Value			
	Connect Option	Auto		
		DMX		
		Art-Net		
		sACN		
	Network	IP Address	Default 1:002.xxx.xxx.xxx	
			Default 2:010.xxx.xxx.xxx	
		Manual:xxx.xxx.xxx.xxx		
		Subnet Mask	xxx.xxx.xxx.xxx	
	Art-Net Settings	Net	0-127	(Default=0)
		Subnet	0-15	(Default=0)
		Universe	0-15	(Default=0)
sACN Settings	Universe	1-32000	(Default=1)	
	Priority	0-200	(Default=100)	
Network to DMX	No			

MAIN MENU	SUBMENU	CHOICES/VALUES	
		Yes	
Fixture Settings	Pan Invert	No	
		Yes	
	Tilt Invert	No	
		Yes	
	P/T Feedback	No	
		Yes	
	Dimmer Curve	Linear	
		Square Law	
		Inv SQ Law	
		S Curve	
	Dimmer Speed	Fast	
		Smooth	
	White Balance	Red All	125-255
		Green All	125-255
		Blue All	125-255
		Lime All	125-255
		Red 1	125-255
		Green 1	125-255
		Blue 1	125-255
		Lime 1	125-255
	
		Red 7	125-255
		Green 7	125-255
		Blue 7	125-255
	LED Refresh Rate	900Hz	
		1000Hz	
		1100Hz	
		1200Hz	
		1300Hz	
		1400Hz	
		1500Hz	
		2500Hz	
4000Hz			
5000Hz			
6000Hz			
10KHz			
15KHz			

MAIN MENU	SUBMENU	CHOICES/VALUES			
		20KHz			
		25KHz			
	Fan Mode	Auto			
		Quiet			
		Theatre			
	Color Calibration	Off			
		On			
	Calibration Mode	Hi CRI			
		Hi Output			
	Dimmer Start Mode	High			
		Low			
	Sun Protection Mode	Off			
		On			
	Display Settings	Display Invert	No		
Yes					
Backlight Intensity		1-10	(Default=10)		
Temperature Unit		°C			
		°F			
Language	English				
	Chinese				
Fixture Test	Auto Test	Single			
		Cycle			
	Manual Test	Mode 1		Mode 2	
		Clear	No/Yes	Clear	No/Yes
		Pan	0-255	Pan	0-255
		Tilt	0-255	Tilt	0-255
		Zoom	0-255	Zoom	0-255
		Dimmer	0-255	Dimmer	0-255
		Strobe	0-255	Strobe	0-255
		Red	0-255	Red 1	0-255
		Green	0-255	Green 1	0-255
		Blue	0-255	Blue 1	0-255
		Lime	0-255	Lime 1	0-255
		CCT	0-255
		Color Macro	0-255	Red 7	0-255
		Green 7	0-255		
		Blue 7	0-255		

MAIN MENU	SUBMENU	CHOICES/VALUES			
				Lime 7	0-255
Fixture Information	Fixture Use Hour				
	LED Use Hour	Total LED Hour			
		LED On Hour			
		LED Hours Reset	Password=050		
	Humidity			Current	Max
		Base			
	Temperature			Current	Max
		LED's	LED 1-7		
		Base	CPU-A		
	Fan State	B_FAN 1-2			
		H_FAN 1-4			
	Firmware Version				
	RDM UID				
	Error Logs	Fixture Errors			
Reset Error Log		No			
		Yes	Password=050		
Reset Function	Pan/Tilt Reset	No			
		Yes			
	Effect Reset	No			
		Yes			
	All Reset	No			
		Yes			
Special Function	USB Upgrade	No			
		Yes	DMX	<i>(Select during firmware upgrades for other fixture models)</i>	
			NET		
	Send Upgrade	No			
		Yes	DMX		
			NET		
	Firmware Restore	No			
		Yes			
	Factory Settings	No			
		Yes			

DMX Settings

Enter the control menu and select **DMX Settings**, press ENTER. Use the UP/DOWN button to select **DMX Address**, **DMX Channel Mode**, **No DMX Status**, **View DMX Value**, **Connect Option**, **Network**, **Art-Net Settings**, **sACN Settings** or **Network to DMX**.

DMX Address

Select **DMX Address**, press ENTER.

Use UP/DOWN button to select an address, confirm your selection with ENTER.

CHANNEL MODE	DMX ADDRESS
Mode 1 (19)	1-494
Mode 2 (41)	1-472
Mode 3 (20)	1-493
Mode 4 (42)	1-471

DMX Channel Mode

Select **DMX Channel Mode**, press ENTER.

Use UP/DOWN button to select between **Mode 1 (19)**, **Mode 2 (41)**, **Mode 3 (20)** and **Mode 4 (42)** confirm your selection with ENTER.

To exit the menu, press MENU, or wait 30 seconds.

No DMX Status

Select **No DMX Status**, press ENTER.

Use UP/DOWN button to select one of the following status:

Blackout (Fixture blacks out if DMX signal stops)

Hold (The device continues to operate in the current mode with the last active DMX values until the signal returns)

Manual (The device accepts the DMX value stored in the 'Manual Test' menu)

Confirm your selection with ENTER.

To exit the menu, press MENU, or wait 30 seconds.

View DMX Value

Select **View DMX Value**, press ENTER.

Use UP/DOWN button to select the desired DMX channel, for which the value is to be displayed.

To exit the menu, press MENU, or wait 30 seconds.

Connect Option

Select **Connect Option**, press ENTER.

Use UP/DOWN button to select **Auto**, **DMX**, **Art-Net** or **sACN**, confirm your selection with ENTER.

To exit the menu, press MENU, or wait 30 seconds.

Network

Select **Network**, press ENTER.

Use UP/DOWN button to select **IP Address** or **Subnet Mask**, confirm your selection with ENTER.

To exit the menu, press MENU, or wait 30 seconds.

Art-Net Settings

Select **Art-Net Settings**, press ENTER.

Use UP/DOWN button to select **Net**, **Subnet** or **Universe**, confirm your selection with ENTER.

To exit the menu, press MENU, or wait 30 seconds.

sACN Settings

Select **sACN Settings**, press ENTER.

Use UP/DOWN button to select **Universe** or **Priority**, confirm your selection with ENTER.

To exit the menu, press MENU, or wait 30 seconds.

Network to DMX

Select **Network to DMX**, press ENTER.

Use UP/DOWN button to select **No** or **Yes**, confirm your selection with ENTER.

To exit the menu, press MENU, or wait 30 seconds.

Fixture Settings

Enter the control menu and select **Fixture Settings**, press ENTER. Use the UP/DOWN button to select **Pan Invert**, **Tilt Invert**, **P/T Feedback**, **Dimmer Curve**, **Dimmer Speed**, **White Balance**, **LED Refresh Rate**, **Fan Mode**, **Color Calibration**, **Calibration Mode**, **Dimmer Start Mode** or **Sun Protection Mode**.

Pan Invert

Select **Pan Invert**, press ENTER.

Use UP/DOWN button to select **No** (pan invert deactivated) or **Yes** (pan invert activated), confirm your selection with ENTER.

To exit the menu, press MENU, or wait 30 seconds.

Tilt Invert

Select **Tilt Invert**, press ENTER.

Use UP/DOWN button to select **No** (tilt invert deactivated) or **Yes** (tilt invert activated), confirm your selection with ENTER.

To exit the menu, press MENU, or wait 30 seconds.

P/T Feedback

Select **P/T Feedback**, press ENTER.

Use UP/DOWN button to select **No** (pan/tilt feedback deactivated) or **Yes** (pan/tilt feedback activated), confirm your selection with ENTER.

To exit the menu, press MENU, or wait 30 seconds.

Dimmer Curve

Select **Dimmer Curve**, press ENTER.

Use UP/DOWN button to select **Linear**, **Square Law**, **Inv SQ Law** or **S Curve**, confirm your selection with ENTER.

Dimmer Modes

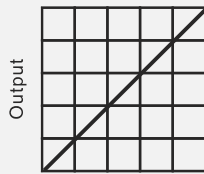

Optically Linear

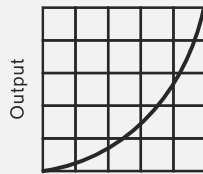

Square Law

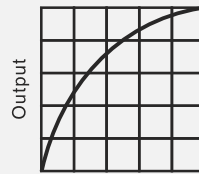

Inverse Square Law

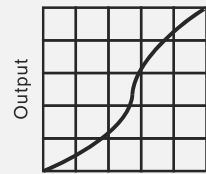

S-curve

To exit the menu, press MENU, or wait 30 seconds.

Dimmer Speed

Select **Dimmer Speed**, press ENTER.

Use UP/DOWN button to select **Fast** or **Smooth**, confirm your selection with ENTER.

To exit the menu, press MENU, or wait 30 seconds.

White Balance

Select **White Balance**, press ENTER.

Use UP/DOWN button to select **Red All**, **Green All**, **Blue All**, **Lime All**, **Red 1**, **Green 1**, **Blue 1**, **Lime 1.....** or **Red 7**, **Green 7**, **Blue 7**, confirm your selection with ENTER.

Use UP/DOWN button to select a value between **125** and **255**, confirm your selection with ENTER.

To exit the menu, press MENU, or wait 30 seconds.

LED Refresh Rate

Select **LED Refresh Rate**, press ENTER.

Use UP/DOWN button to select **900Hz**, **1000Hz**, **1100Hz**, **1200Hz**, **1300Hz**, **1400Hz**, **1500Hz**, **2500Hz**, **4000Hz**, **5000Hz**, **6000Hz**, **10KHz**, **15KHz**, **20KHz** or **25KHz**, confirm your selection with ENTER.

To exit the menu, press MENU, or wait 30 seconds.

Fan Mode

Select **Fan Mode**, press ENTER.

Use UP/DOWN button to select **Auto**, **Quiet** or **Theatre**, confirm your selection with ENTER.

To exit the menu, press MENU, or wait 30 seconds.

Color Calibration

Select **Color Calibration**, press ENTER.

Use UP/DOWN button to select **Off** or **On**, confirm your selection with ENTER.

To exit the menu, press MENU, or wait 30 seconds.

Calibration Mode

Select **Calibration Mode**, press ENTER.

Use UP/DOWN button to select **Hi CRI** or **Hi Output**, confirm your selection with ENTER.

To exit the menu, press MENU, or wait 30 seconds.

Dimmer Start Mode

Select **Dimmer Start Mode**, press ENTER.

Use UP/DOWN button to select **High** (high dimming start) or **Low** (low dimming start), confirm your selection with ENTER.

To exit the menu, press MENU, or wait 30 seconds.

Sun Protection Mode (Set the 'Sun Protection Mode' to 'On' when using the fixture outdoors.)

Select **Sun Protection Mode**, press ENTER.

Use UP/DOWN button to select **Off** (sun protection mode deactivated) or **On** (The fixture will turn off the light source and automatically turn its head to a horizontal position when no signal is detected, preventing damage to optical components or internal parts from prolonged direct sunlight exposure.), confirm your selection with ENTER.

To exit the menu, press MENU, or wait 30 seconds.

Display Settings

Enter the control menu and select **Display Settings**, press ENTER. Use the UP/DOWN button to select **Display Invert**, **Backlight Intensity**, **Temperature Unit** or **Language**.

Display Invert

Select **Display Invert**, press ENTER.

Use UP/DOWN button to select **No** (display normal) or **Yes** (display inverted), confirm your selection with ENTER.

To exit the menu, press MENU, or wait 30 seconds.

Backlight Intensity

Select **Backlight Intensity**, press ENTER.

Use UP/DOWN button to select a value between **1** (dark) and **10** (bright), confirm your selection with ENTER.

To exit the menu, press MENU, or wait 30 seconds.

Temperature Unit

Select **Temperature Unit**, press ENTER.

Use UP/DOWN button to select **°C** or **°F**, confirm your selection with ENTER.

To exit the menu, press MENU, or wait 30 seconds.

Language

Select **Language**, press ENTER.

Use UP/DOWN button to select **English** or **Chinese**, confirm your selection with ENTER.

To exit the menu, press MENU, or wait 30 seconds.

Fixture Test

Enter the control menu and select **Fixture Test**, press ENTER. Use the UP/DOWN button to select **Auto Test** or **Manual Test**.

Auto Test

Select **Auto Test**, press ENTER.

Use UP/DOWN button to select **Single** (the device immediately performs a single automatic self-test) or **Cycle** (the device immediately performs a cyclic automatic self-test), confirm your selection with ENTER.

To exit the menu, press MENU.

Manual Test

Select **Manual Test**, press ENTER.

Use UP/DOWN button to select the channel for which the manual test is to be performed, confirm your selection with ENTER.

Use UP/DOWN button to select a value, confirm your selection with ENTER.

To exit the menu, press MENU.

(The device returns to its original DMX state after the manual test. The test values are saved automatically when the device is switched off.)

Fixture Information

Enter the control menu and select **Fixture Information**, press ENTER. Use the UP/DOWN button to select **Fixture Use Hour**, **LED Use Hour**, **Humidity**, **Temperature**, **Fan State**, **Firmware Version**, **RDM UID** or **Error Logs**.

Fixture Use Hour

Select **Fixture Use Hour**, press ENTER.

The operating hours is displayed.

To exit the menu, press MENU, or wait 30 seconds.

LED Use Hour

Select **LED Use Hour**, press ENTER.

Use UP/DOWN button to select **Total LED Hour** (total time) or **LED On Hour** (current switch-on time), confirm your selection with ENTER.

The total time or current switch-on time is displayed.

Use UP/DOWN button to select **LED Hours Reset**, confirm your selection with ENTER.

Use UP/DOWN button to set the password 050, confirm your selection with ENTER. The LED operating hours is reset.

To exit the menu, press MENU, or wait 30 seconds.

Humidity

Select **Humidity**, press ENTER.

The device humidity is displayed.

To exit the menu, press MENU, or wait 30 seconds.

Temperature

Select **Temperature**, press ENTER.

The device temperature is displayed.

To exit the menu, press MENU, or wait 30 seconds.

Fan State

Select **Fan State**, press ENTER.

The fan status is displayed.

To exit the menu, press MENU, or wait 30 seconds.

Firmware Version

Select **Firmware Version**, press ENTER.

The firmware version is displayed.

To exit the menu, press MENU, or wait 30 seconds.

RDM UID

Select **RDM UID**, press ENTER.

The RDM UID is displayed.

To exit the menu, press MENU, or wait 30 seconds.

Error Logs

Select **Error Logs**, press ENTER.

Use UP/DOWN button to select **Fixture Errors**, confirm your selection with ENTER.

The error list is displayed.

Use UP/DOWN button to select **Reset Error Log**, confirm your selection with ENTER.

If you wish to reset the relevant error logs, select **Yes**. If you do not wish to reset anything, select **No**. Confirm your selection with ENTER.

If you select **Yes**, use UP/DOWN button to set the password 050, confirm your selection with ENTER. The relevant error logs are reset.

To exit the menu, press MENU, or wait 30 seconds.

Reset Function

Enter the control menu and select **Reset Function**, press ENTER. Use the UP/DOWN button to select **Pan/Tilt Reset**, **Effect Reset** or **All Reset**.

Pan/Tilt Reset

Select **Pan/Tilt Reset**, press ENTER.

Use UP/DOWN button to select **No** or **Yes** (the device will run built-in program to reset pan/tilt to their home positions), confirm your selection with ENTER.

To exit the menu, press MENU, or wait 30 seconds.

Effect Reset

Select **Effect Reset**, press ENTER.

Use UP/DOWN button to select **No** or **Yes** (the device will run built-in program to reset effect to their home positions), confirm your selection with ENTER.

To exit the menu, press MENU, or wait 30 seconds.

All Reset

Select **All Reset**, press ENTER.

Use UP/DOWN button to select **No** or **Yes** (the device will run built-in program to reset all to their home positions), confirm your selection with ENTER.

To exit the menu, press MENU, or wait 30 seconds.

Special Function

Enter the control menu and select **Special Function**, press ENTER. Use the UP/DOWN button to select **USB Upgrade**, **Send Upgrade**, **Firmware Restore** or **Factory Settings**.

USB Upgrade

Select **USB Upgrade**, press ENTER.

The upgrade files are displayed. (See the 'Updating Software' section for details.)

To exit the menu, press MENU, or wait 30 seconds.

Send Upgrade

Select **Send Upgrade**, press ENTER.

If you wish to send upgrade files from this fixture to other fixtures to upgrade their firmware, select **Yes**. Then use UP/DOWN button to select **DMX** (send upgrade via DMX) or **NET** (send upgrade via Ethernet), confirm your selection with ENTER. Once selected, the display of this fixture will show “**Sending Packet, Please Wait...**” while the display of other fixtures will show “**Upgrading, Please Wait...**”. A percentage bar will also be displayed. After the update is complete, fixtures will perform a reset (this can take some time).

If you do not wish to send anything, select **No**. Confirm your selection with ENTER.

To exit the menu, press MENU, or wait 30 seconds.

Firmware Restore (After replacing fixture's vice board(s), this function allows you to synchronize the main board's software to all vice board(s), as the software version of the replaced vice board(s) may not consistent with that of the main board.)

Select **Firmware Restore**, press ENTER.

If you wish to restore fixture's firmware, select **Yes**. Once Yes is selected, the display will show “**Upgrading, Please Wait...**”. A percentage bar will also be displayed. After the update is complete, the fixture will perform a reset (this can take some time).

If you do not wish to restore anything, select **No**. Confirm your selection with ENTER.

To exit the menu, press MENU, or wait 30 seconds.

Factory Settings

Select **Factory Settings**, press ENTER.

If you wish to reset the device to the factory settings, select **Yes**. If you do not wish to reset anything, select **No**. Confirm your selection with ENTER.

To exit the menu, press MENU, or wait 30 seconds.

6.2 Updating Software

Only qualified technicians should perform this function! Note all menu settings before updating software! Please note, up to 32 fixtures can be connected together and updated at the same time.

Note: Before using the USB flash drive to update the software, please ensure that the USB flash drive is formatted with the FAT32 file system. Otherwise, you will need to reformat the USB flash drive to FAT32 before transferring the .yfu files, as the fixture will only recognize the files stored on a FAT32 formatted drive.

Format the USB flash drive:

- ▶ Connect the USB flash drive to the computer.
- ▶ Right-click on the USB flash drive disk.
- ▶ Click "Format".
- ▶ Select the "FAT32" file system and click "Start".

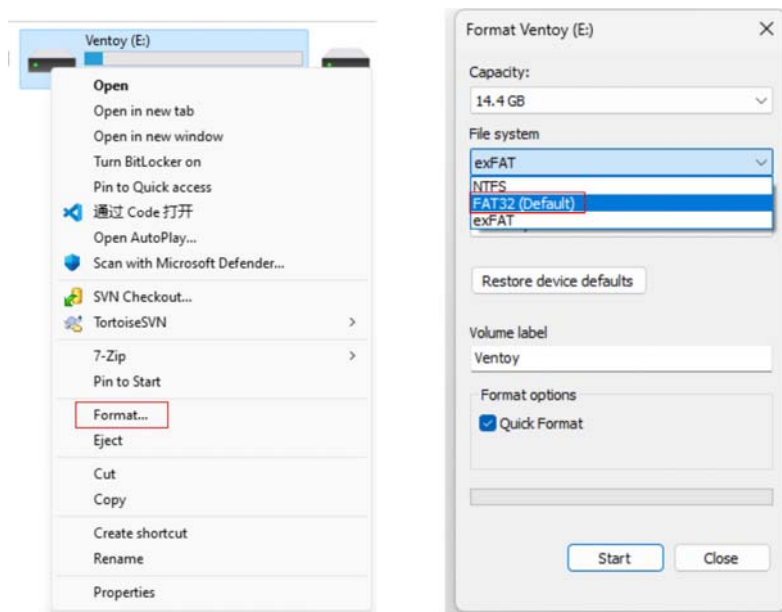

Updating Software (on this fixture):

1. Download the software update files from the ACME website.
2. Copy the software files to a compatible USB flash drive.

Note: To avoid the risk of uploading the wrong file to the fixture, make sure that there are no other files on your flash drive.

3. Disconnect DMX and Ethernet connections and power the fixture on.
4. Insert the USB flash drive into the **FIRMWARE UPGRADE** port located on the rear panel of the fixture.
5. Locate **“Special Function”** within the system menu and press ENTER. Scroll to the **“USB Upgrade”** submenu and press ENTER.
6. Two software files will be displayed as downloaded earlier. Highlight the first file (V00) and press ENTER. Select **“Yes”** to begin the first of two updating processes. Once Yes is selected, the display will show **“Copying Files, Please Wait...”**. After copying is complete, the display will show **“Upgrading, Please Wait...”**. A percentage bar will also be displayed.
7. After the first update is complete, the fixture will perform a reset (this can take some time).
8. Once the reset is complete, scroll to the **“Special Function”** menu again and press ENTER. Scroll to the **“USB Upgrade”** submenu and press ENTER.
9. Highlight the second file (Vxx) this time and press ENTER. Select **“Yes”** to begin the second and final updating process. Once Yes is selected, the display will show **“Copying Files, Please Wait...”** again. After copying is complete, the display will show **“Upgrading, Please Wait...”**. A percentage bar will also be displayed.
10. After the second update is complete, the fixture will perform another reset (this can take some time as well).
11. Remove the USB flash drive.
12. After the reset process is complete, check the new software version to confirm it is updated to the most recent software.

Updating Software (for other fixture models):

1. Download the software update files from the ACME website.
2. Copy the software files to a compatible USB flash drive.

Note: To avoid the risk of uploading the wrong file to the fixture, make sure that there are no other files on your flash drive.

3. Disconnect DMX and Ethernet connections and power the fixture on.
4. Connect the fixtures to be upgraded to this fixture using a DMX signal cable or Ethernet cable.

Note: For DMX cable connections, ensure “DMX” is selected as the signal source. For Ethernet cable connections, select “NET” as the signal source.

5. Insert the USB flash drive into the **FIRMWARE UPGRADE** port located on the rear panel of the fixture.
6. Locate **“Special Function”** within the system menu and press ENTER. Scroll to the **“USB Upgrade”** submenu and press ENTER.
7. Two software files will be displayed as downloaded earlier. Highlight the first file (V00) and press ENTER. Select **“Yes”** and then specify the signal source - **DMX** (send upgrade via DMX) or **NET** (send upgrade via Ethernet) to begin the first of two updating processes. Once selected, the display of this fixture will show **“Copying Files, Please Wait...”**. After copying is complete, the display of this fixture will show **“Sending Packet, Please Wait...”** while the display of other fixtures will show **“Upgrading, Please Wait...”**. A percentage bar will also be displayed.
8. After the first update is complete, the fixtures will perform a reset (this can take some time).
9. Once the reset is complete, scroll to the **“Special Function”** menu again and press ENTER. Scroll to the **“USB Upgrade”** submenu and press ENTER.
10. Highlight the second file (Vxx) this time and press ENTER. Select **“Yes”** and then specify the signal source again to begin the second and final updating process. Once selected, the display of this fixture will show **“Copying Files, Please Wait...”** again. After copying is complete, the display of this fixture will show **“Sending Packet, Please Wait...”** while the display of other fixtures will show **“Upgrading, Please Wait...”**. A percentage bar will also be displayed.
11. After the second update is complete, the fixtures will perform another reset (this can take some time as well).

12. Remove the USB flash drive.

13. After the reset process is complete, check the new software version to confirm it is updated to the most recent software.

RDM functions: Certain menus of the device and functions can be called up via the RDM protocol.

The parameter IDs are implemented as follows for different commands:

Standard RDM Parameter IDs

PID	Parameter IDs	Command 'Discovery'	Command 'Set'	Command 'Get'
0x0001	DISC_UNIQUE_BRANCH	✓		
0x0002	DISC_MUTE	✓		
0x0003	DISC_UN_MUTE	✓		
0x0050	SUPPORTED_PARAMETERS			✓
0x0051	PARAMETER_DESCRIPTION			✓
0x0060	DEVICE_INFO			✓
0x0080	DEVICE_MODEL_DESCRIPTION			✓
0x0081	MANUFACTURER_LABEL			✓
0x0082	DEVICE_LABEL		✓	✓
0x0090	FACTORY_DEFAULTS		✓	✓
0x00C0	SOFTWARE_VERSION_LABEL			✓
0x00C1	BOOT_SOFTWARE_VERSION_ID			✓
0x00C2	BOOT_SOFTWARE_VERSION_LABEL			✓
0x00E0	DMX_PERSONALITY		✓	✓
0x00E1	DMX_PERSONALITY_DESCRIPTION			✓
0x00F0	DMX_START_ADDRESS		✓	✓
0x0120	SLOT_INFO			✓
0x0121	SLOT_DESCRIPTION			✓
0x0200	SENSOR_DEFINITION			✓
0x0201	SENSOR_VALUE			✓
0x0343	CURVE		✓	✓
0x0344	CURVE_DESCRIPTION			✓
0x0400	DEVICE_HOURS			✓
0x0401	LAMP_HOURS			✓
0x0600	PAN_INVERT		✓	✓
0x0601	TILT_INVERT		✓	✓
0x1000	IDENTIFY_DEVICE		✓	✓
0x1001	RESET_DEVICE		✓	✓

✓ -Command implemented for the respective parameter ID

Manufacturer-specific RDM Parameter IDs

PID	Parameter IDs	Command 'Discovery'	Command 'Set'	Command 'Get'	Note
0xA004	DMX_STATUS		✓	✓	0:Blackout 1:Hold 2:Manual
0xA008	DIMMER_SPEED		✓	✓	0:Fast 1:Smooth
0xA010	FAN_MODE		✓	✓	0:Auto 1:Quiet 2:Theatre
0xA018	ERROR_LOG			✓	
0xA020	OFFSET		✓	✓	
0xA021	PAN_TILT_FEEDBACK		✓	✓	0:No 1:Yes
0xA023	CALIBRATION_ONOFF		✓	✓	0:Off 1:On
0xA024	CALIBRATION_MODE		✓	✓	0:Hi CRI 1:Hi Output
0xA025	DIMMER_CURVE		✓	✓	1:Linear 2:Square Law 3:Inv SQ Law 4:S Curve
0xA026	DIMMER_FREQUENCY		✓	✓	1:900Hz 2:1000Hz 3:1100Hz 4:1200Hz 5:1300Hz 6:1400Hz 7:1500Hz 8:2500Hz 9:4000Hz 10:5000Hz 11:6000Hz 12:10KHz 13:15KHz 14:20KHz 15:25KHz
0xA029	SUN_PROTECTION_MODE		✓	✓	0:Off 1:On

✓ -Command implemented for the respective parameter ID

6.3 Home Position Adjustment

- ▶ To access the control menus, press the [MENU] button.
- ▶ To access the offset menus, long-press the [ENTER] button.
- ▶ Navigate the offset menus, using the [ENTER], [▲ UP] and [▼ DOWN] buttons.
- ▶ To select a menu option or to confirm a selection, press the [ENTER] button.
- ▶ To return to a higher level in the menu structure without making a change, press the [MENU] button, or wait 30 seconds.

OFFSET MENU	VALUES
Frequency(Hz)	1072~1327
Pan	-128~127
Tilt	-128~127
Zoom	-128~127
Red	-128~127
Green	-128~127
Blue	-128~127
Lime	-128~127
Red 1	-128~127
Green 1	-128~127
Blue 1	-128~127
Lime 1	-128~127
.....
Red 7	-128~127
Green 7	-128~127
Blue 7	-128~127
Lime 7	-128~127

Frequency(Hz)

Select **Frequency(Hz)**, press ENTER.

Use UP/DOWN button to select a value, confirm your selection with ENTER.

To exit the offset menu, press MENU, or wait 30 seconds.

Frequency	VALUES
900Hz	772~1027
1000Hz	872~1127
1100Hz	972~1227
1200Hz	1072~1327
1300Hz	1172~1427
1400Hz	1272~1527
1500Hz	1372~1627
2500Hz	2372~2627
4000Hz	3872~4127
5000Hz	4872~5127
6000Hz	5872~6127
10KHz	9872~10127
15KHz	14872~15127
20KHz	19872~20127
25KHz	24872~25127

Pan

Select **Pan**, press ENTER.

Use UP/DOWN button to select a value between -128 and 127, confirm your selection with ENTER.

To exit the offset menu, press MENU, or wait 30 seconds.

Tilt

Select **Tilt**, press ENTER.

Use UP/DOWN button to select a value between -128 and 127, confirm your selection with ENTER.

To exit the offset menu, press MENU, or wait 30 seconds.

Zoom

Select **Zoom**, press ENTER.

Use UP/DOWN button to select a value between -128 and 127, confirm your selection with ENTER.

To exit the offset menu, press MENU, or wait 30 seconds.

Strobe

Select **Strobe**, press ENTER.

Use UP/DOWN button to select a value between -128 and 127, confirm your selection with ENTER.

To exit the offset menu, press MENU, or wait 30 seconds.

Red

Select **Red**, press ENTER.

Use UP/DOWN button to select a value between -128 and 127, confirm your selection with ENTER.

To exit the offset menu, press MENU, or wait 30 seconds.

Green

Select **Green**, press ENTER.

Use UP/DOWN button to select a value between -128 and 127, confirm your selection with ENTER.

To exit the offset menu, press MENU, or wait 30 seconds.

Blue

Select **Blue**, press ENTER.

Use UP/DOWN button to select a value between -128 and 127, confirm your selection with ENTER.

To exit the offset menu, press MENU, or wait 30 seconds.

Lime

Select **Lime**, press ENTER.

Use UP/DOWN button to select a value between -128 and 127, confirm your selection with ENTER.

To exit the offset menu, press MENU, or wait 30 seconds.

Red 1

Select **Red 1**, press ENTER.

Use UP/DOWN button to select a value between -128 and 127, confirm your selection with ENTER.

To exit the offset menu, press MENU, or wait 30 seconds.

Green 1

Select **Green 1**, press ENTER.

Use UP/DOWN button to select a value between -128 and 127, confirm your selection with ENTER.

To exit the offset menu, press MENU, or wait 30 seconds.

Blue 1

Select **Blue 1**, press ENTER.

Use UP/DOWN button to select a value between -128 and 127, confirm your selection with ENTER.

To exit the offset menu, press MENU, or wait 30 seconds.

Lime 1

Select **Lime 1**, press ENTER.

Use UP/DOWN button to select a value between -128 and 127, confirm your selection with ENTER.

To exit the offset menu, press MENU, or wait 30 seconds.

.....

Red 7

Select **Red 7**, press ENTER.

Use UP/DOWN button to select a value between -128 and 127, confirm your selection with ENTER.

To exit the offset menu, press MENU, or wait 30 seconds.

Green 7

Select **Green 7**, press ENTER.

Use UP/DOWN button to select a value between -128 and 127, confirm your selection with ENTER.

To exit the offset menu, press MENU, or wait 30 seconds.

Blue 7

Select **Blue 7**, press ENTER.

Use UP/DOWN button to select a value between -128 and 127, confirm your selection with ENTER.

To exit the offset menu, press MENU, or wait 30 seconds.

Lime 7

Select **Lime 7**, press ENTER.

Use UP/DOWN button to select a value between -128 and 127, confirm your selection with ENTER.

To exit the offset menu, press MENU, or wait 30 seconds.

07/ Configuring the Device for DMX Control

7.1 Address Setting

All fixtures should be given a DMX starting address when operating with a DMX controller, in order to ensure that the correct fixture responds to the correct control signal. Incorrect settings will result in unpredictable responses from the lighting controller.

You can set the same starting address for all fixtures or a group of fixtures, or set different addresses for each individual fixture.

Setting all fixtures to the same DMX address will cause all fixtures to react in the same way. In this case, please note that changing the settings of one channel will affect all the fixtures simultaneously.

If you set each fixture to a different DMX address, each unit will “listen” starting at the channel number you have set, based on the quantity of DMX channels of each fixture. That means changing the settings of one channel will only affect the selected fixture.

For example, if the first fixture is set to 19 ch DMX mode with a start DMX address of 1, the following fixture in the DMX chain should then be set to a DMX address of 20. As the first fixture uses all the first 19 DMX channels, the next available channel is 20 ($19+1=20 >> 20$).

See the chart below for more details:

Channel Mode	Unit 1 Address	Unit 2 Address	Unit 3 Address	Unit 4 Address	Unit xxx Address
19 channels	1	20	39	58
41 channels	1	42	83	124
20 channels	1	21	41	61
42 channels	1	43	85	127

7.2 DMX Protocol

Valid from firmware version: V1.2

CHANNEL				VALUE	FUNCTION
19ch	41ch	20ch	42ch		
1	1	1	1	000-255	PAN 0°→540°
2	2	2	2	000-255	PAN FINE
3	3	3	3	000-255	TILT 0°→210°
4	4	4	4	000-255	TILT FINE
5	5	5	5	000-255	PAN/TILT SPEED Fast to Slow
6	6	6	6	000-255	ZOOM Narrow→Wide
7	7	7	7	000-255	ZOOM FINE
8	8	8	8	000-255	DIMMER 0%→100%
9	9	9	9	000-255	DIMMER FINE
10	10	10	10	000-007	STROBE Close
				008-015	Open
				016-131	Strobe from Slow to Fast
				132-139	Open
				140-181	Fast Open Slow Close from Slow to Fast
				182-189	Open
				190-231	Slow Open Fast Close from Slow to Fast
				232-239	Open
240-247	Random Strobe from Slow to Fast				
248-255	Open				
11	11	11	11	000-029	FUNCTION (To activate following functions, stop in DMX value for at least 3 seconds.) Null
				030-039	Dimmer Curve Linear
				040-049	Dimmer Curve Square Law
				050-059	Dimmer Curve Inv Square Law
				060-069	Dimmer Curve S
				070-079	Fan Mode: Quiet

				080-089	Fan Mode: Auto
				090-099	Fan Mode: Theatre
				100-109	LED Frequency Setting Enable
				110-119	LED Frequency Setting Disable
				120-122	Null
				123	900Hz
				124	1000Hz
				125	1100Hz
				126	1200Hz
				127	1300Hz
				128	1400Hz
				129	1500Hz
				130	2500Hz
				131	4000Hz
				132	5000Hz
				133	6000Hz
				134	10KHz
				135	15KHz
				136	20KHz
				137	25KHz
				138-139	Null
				140-149	Reset Pan/Tilt
				150-159	Reset Effect
				160-169	Color Calibration: On
				170-179	Color Calibration: Off
				180-189	Calibration Mode: High CRI
				190-199	Calibration Mode: High Output
				200-209	Reset All
				210-219	Dimmer Speed Fast
				220-229	Dimmer Speed Smooth
				230	Dimmer Start Mode: High
				231	Dimmer Start Mode: Low
				232-233	Sun Protection Mode: On
				234-235	Sun Protection Mode: Off
				236-255	Null
12		12		000-255	RED 0%→100%
13		13		000-255	GREEN 0%→100%
14		14		000-255	BLUE 0%→100%
15		15		000-255	LIME 0%→100%
	12		12	000-255	RED 1 0%→100%
	13		13	000-255	GREEN 1 0%→100%

	14		14	000-255	BLUE 1 0%→100%
	15		15	000-255	LIME 1 0%→100%
	16		16	000-255	RED 2 0%→100%
	17		17	000-255	GREEN 2 0%→100%
	18		18	000-255	BLUE 2 0%→100%
	19		19	000-255	LIME 2 0%→100%
	20		20	000-255	RED 3 0%→100%
	21		21	000-255	GREEN 3 0%→100%
	22		22	000-255	BLUE 3 0%→100%
	23		23	000-255	LIME 3 0%→100%
	24		24	000-255	RED 4 0%→100%
	25		25	000-255	GREEN 4 0%→100%
	26		26	000-255	BLUE 4 0%→100%
	27		27	000-255	LIME 4 0%→100%
	28		28	000-255	RED 5 0%→100%
	29		29	000-255	GREEN 5 0%→100%
	30		30	000-255	BLUE 5 0%→100%
	31		31	000-255	LIME 5 0%→100%
	32		32	000-255	RED 6 0%→100%
	33		33	000-255	GREEN 6 0%→100%
	34		34	000-255	BLUE 6 0%→100%
	35		35	000-255	LIME 6 0%→100%

	36		36	000-255	RED 7 0%→100%
	37		37	000-255	GREEN 7 0%→100%
	38		38	000-255	BLUE 7 0%→100%
	39		39	000-255	LIME 7 0%→100%
					CCT (8000K-2500K)
				000	Null
				001-004	8000K
				005-009	7900K
				010-013	7800K
				014-018	7700K
				019-022	7600K
				023-027	7500K
				028-031	7400K
				032-036	7300K
				037-040	7200K
				041-045	7100K
				046-049	7000K
				050-054	6900K
				055-058	6800K
				059-063	6700K
				064-067	6600K
				068-072	6500K
				073-076	6400K
16	40	16	40	077-081	6300K
				082-085	6200K
				086-090	6100K
				091-094	6000K
				095-099	5900K
				100-103	5800K
				104-108	5700K
				109-112	5600K
				113-117	5500K
				118-121	5400K
				122-126	5300K
				127-130	5200K
				131-135	5100K
				136-139	5000K
				140-144	4900K
				145-148	4800K
				149-153	4700K
				154-157	4600K
				158-162	4500K
				163-166	4400K

				167-171	4300K
				172-175	4200K
				176-180	4100K
				181-184	4000K
				185-189	3900K
				190-193	3800K
				194-198	3700K
				199-202	3600K
				203-207	3500K
				208-211	3400K
				212-216	3300K
				217-220	3200K
				221-225	3100K
				226-229	3000K
				230-234	2900K
				235-238	2800K
				239-243	2700K
				244-247	2600K
				248-255	2500K
					COLOR MACRO
				000-009	Null
				010-016	LEE 790 – Moroccan Pink
				017-023	LEE 157 – Pink
				024-030	LEE 332 – Special Rose Pink
				031-037	LEE 328 – Follies Pink
				038-044	LEE 345 – Fuchsia Pink
				045-051	LEE 194 – Surprise Pink
				052-058	LEE 181 – Congo Blue
				059-065	LEE 071 – Tokyo Blue
				066-072	LEE 120 – Deep Blue
				073-079	LEE 079 – Just Blue
				080-086	LEE 132 – Medium Blue
				087-093	LEE 200 – Double CT Blue
				094-100	LEE 161 – State Blue
				101-107	LEE 201 – Full CT Blue
				108-114	LEE 202 – Half CT Blue
				115-121	LEE 117 – Steel Blue
				122-128	LEE 353 – Lighter Blue
				129-135	LEE 118 – Light Blue
				136-142	LEE 116 – Medium Blue Green
				143-149	LEE 124 – Dark Green
				150-156	LEE 139 – Primary Green
				157-163	LEE 089 – Moss Green
				164-170	LEE 122 – Fern Green
				171-177	LEE 738 – JAS Green
				178-184	LEE 088 – Lime Green
				185-191	LEE 100 – Spring Yellow
17	41	17	41		

				192-198 199-205 206-212 213-219 220-226 227-233 234-255	LEE 104 - Deep Amber LEE 179 - Chrome Orange LEE 105 - Orange LEE 021 - Gold Amber LEE 778 - Millennium Gold LEE 135 - Deep Gold Amber LEE 164 - Flame Red
		18	42	000-255	Cross Fade COLOR->CTO
18		19		000-007 008-024 025-041 042-058 059-075 076-092 093-109 110-126 127-143 144-160 161-177 178-194 195-211 212-228 229-245 246-255	MACRO EFFECT Null Effect 1 Effect 2 Effect 3 Effect 4 Effect 5 Effect 6 Effect 7 Effect 8 Effect 9 Effect 10 Effect 11 Effect 12 Meteor Effect 1 Meteor Effect 2 Rainbow Effect
19		20		000 001-127 128 129-255	MACRO EFFECT SPEED Stop Slow to Fast without Fade Stop Slow to Fast with Fade

08/ Error Information

Error codes are shown continuously in the display when the fixture fails and they will not disappear until the fixture is repaired.

CPU-B/C/D/E Error

Check whether the 485 (DATA) leads on the PCB board are installed in place or disconnected.

Check whether the related 485 (DATA) signal circuit on the PCB board is damaged.

Network Error

Check whether the net model is installed in place.

Check whether the net model is damaged.

Check whether the network is normal.

Color Cal Error

Check if the color calibration IC is damaged.

Check whether the color calibration IC board is inserted well and whether the electronic components are well soldered.

Check if the motherboard is malfunctioning.

Check whether the R76 bit resistors and other components on the motherboard are well soldered.

Led Temp. 1/2/3/4/5/6/7 Error

Check whether the temperature detecting board is normal.

Check whether the components of the temperature detecting board are damaged.

Check whether the lead on the temperature detecting board is installed in place or disconnected.

LED Timeout Use

LED Too Hot Off

When the fixture temperature reaches 85°C, it will automatically turn off to protect the fixture.

Pan Reset Error

Check whether the position of the pan where the magnet is installed falls off or is damaged.

Check whether there are obstacles in the pan operating range.

Check whether the Hall element on the pan is damaged.

Check whether the lead connecting the Hall element on the pan and the PCB board is in poor contact or disconnected.

Check whether the motor on the pan is damaged.

Check whether the related circuit of the motor drive board on the pan is damage.

Pan Encode Error

Check whether the encoder on the pan is damaged.

Check whether the lead connecting the encoder on the pan and the PCB board is in poor contact or disconnected.

Pan Encode No Find

Check whether the lead connecting the encoder on the pan and the PCB board is in poor contact or disconnected.

Pan Encode Disable

Check whether the encoder on the pan is damaged.

Tilt Reset Error

Check whether the position of the tilt where the magnet is installed falls off or is damaged.

Check whether there are obstacles in the tilt operating range.

Check whether the Hall element on the tilt is damaged.

Check whether the lead connecting the Hall element on the tilt and the PCB board is in poor contact or disconnected.

Check whether the motor on the tilt is damaged.

Check whether the related circuit of the motor drive board on the tilt is damaged.

Tilt Encode Error

Check whether the encoder on the tilt is damaged.

Check whether the lead connecting the encoder on the tilt and the PCB board is in poor contact or disconnected.

Tilt Encode No Find

Check whether the lead connecting the encoder on the tilt and the PCB board is in poor contact or disconnected.

Tilt Encode Disable

Check whether the encoder on the tilt is damaged.

Base Fan 1/2 Start Error

Check whether the fan is not running.

Check whether the fan leads are installed in place or disconnected.

Check whether the fan is damaged.

Check whether there are obstacles in the fan operating range.

Zoom Reset Error

Check whether the position of the zoom where the magnet is installed falls off or is damaged.

Check whether there are obstacles in the zoom operating range.

Check whether the Hall element on the zoom is damaged.

Check whether the lead connecting the Hall element on the zoom and the PCB board is in poor contact or disconnected.

Check whether the motor on the zoom is damaged.

Check whether the related circuit of the motor drive board on the zoom is damaged.

Head Fan 1/2/3/4 Start Error

Check whether the fan is not running.

Check whether the fan leads are installed in place or disconnected.

Check whether the fan is damaged.

Check whether there are obstacles in the fan operating range.

Base Humidity Error

Check whether the humidity sensor is faulty.

Check whether the lead connecting the humidity sensor is installed in place or disconnected.

Base Humi. Too High

Disassemble the housing of the fixture to dehumidify.

Memory Error

When the memory IC keeps reporting errors, please replace the motherboard.

Position of cooling fans:

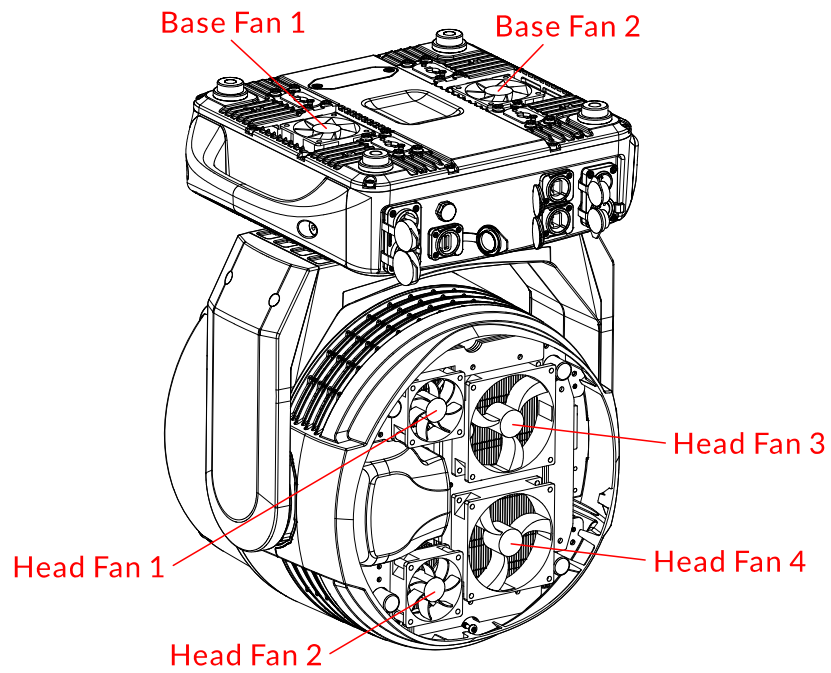

Cooling Fans	Part Number	V	W	Position
Base Fan 1	3014001422	DC 24V	3.6W	Base - A
Base Fan 2				
Head Fan 1	3014001394	DC 24V	2.2±10%W	Head - C
Head Fan 2				
Head Fan 3	3014003016	DC 24V	5.3W	Head - C
Head Fan 4				

09/ Troubleshooting

Problem	Potential cause(s)	Remedies
Fixture does not respond or appears to be off.	No power to the fixture.	Confirm that the power is switched on and cables are plugged in.
	No output from PSU.	Replace the PSU.
Fixture suddenly turned off.	Power was turned off.	Check the power supply, switches and breakers.
Light output cuts out intermittently.	Fixture is too hot.	Check fixture's stored error messages for more information. Allow fixture to cool. Clean fixture. Reduce ambient temperature.
Fixture suddenly stopped responding.	DMX cables were disconnected.	Inspect DMX cables.
Fixture operates irregularly / abnormal.	Incorrect DMX address or DMX mode.	Inspect and enter the correct DMX address or mode.
	DMX link is not terminated.	Install a XLR 120ohm DMX termination at the end of the DMX link.
	Bad data link.	Replace or repair defective cables and/or connections.
	One of the fixtures is defective and is disturbing data transmission on the link.	Track and isolate the corrupted fixture. Have the fixture serviced by a qualified technician.
Pan / tilt is skipping / shuddering	Pan/ tilt locks are not released.	Release the pan / tilt locks.
	Obstacles are within the required pan / tilt clearance.	Inspect and remove any obstacles constraining free operation of the pan / tilt.
	The Hall element is damaged.	Replace the Hall element.
	The magnetic steel fell out.	Replace the magnetic steel.

10/ Fixture Cleaning

Regular cleaning is very important for fixture life and performance. Buildup of dust, dirt, smoke particles, fog fluid residues, etc. degrades the fixture's light output and cooling ability. Cleaning schedules for lighting fixtures vary greatly depending on the operating environment. It is therefore impossible to specify precise cleaning intervals for the fixture. Environmental factors that may result in a need for frequent cleaning include:

- ▶ Use of smoke or fog machines.
- ▶ High airflow rates (near air conditioning vents, for example).
- ▶ Airborne dust (from stage effects, building structures and fittings or the natural environment at outdoor events, for example).

If one or more of these factors is present, inspect fixtures within their first few hours of operation to see whether cleaning is necessary. Check again at frequent intervals. This procedure will allow you to assess cleaning requirements in your particular situation.

Follow these precautions when cleaning the fixture:

- ▶ Work in a clean, dry, well-lit area.
- ▶ Use gentle pressure only. A soft lint-free cloth dampened with a solution of water and a mild detergent is recommended, under no circumstances should alcohol, solvents or abrasives be used! Use care when cleaning optical components: surfaces are fragile and easily scratched.

11/ Approvals and Certifications

This product has been tested and found to comply with the following standards:

- 2014/30/EU - Electromagnetic Compatibility (EMC)
- 2014/35/EU - Low Voltage Directive (LVD)
- cETLus Approved (Control #5000057)
- UK SI 2016 No. 1091: Electromagnetic Compatibility Regulations 2016
- UK SI 2016 No. 1101: The Electric Equipment (Safety) Regulations 2016



The information in this document is subject to change without notice.

For the latest information, visit www.acmelighting.com.



www.acmelighting.com