

Acme[®]

SKYTRK

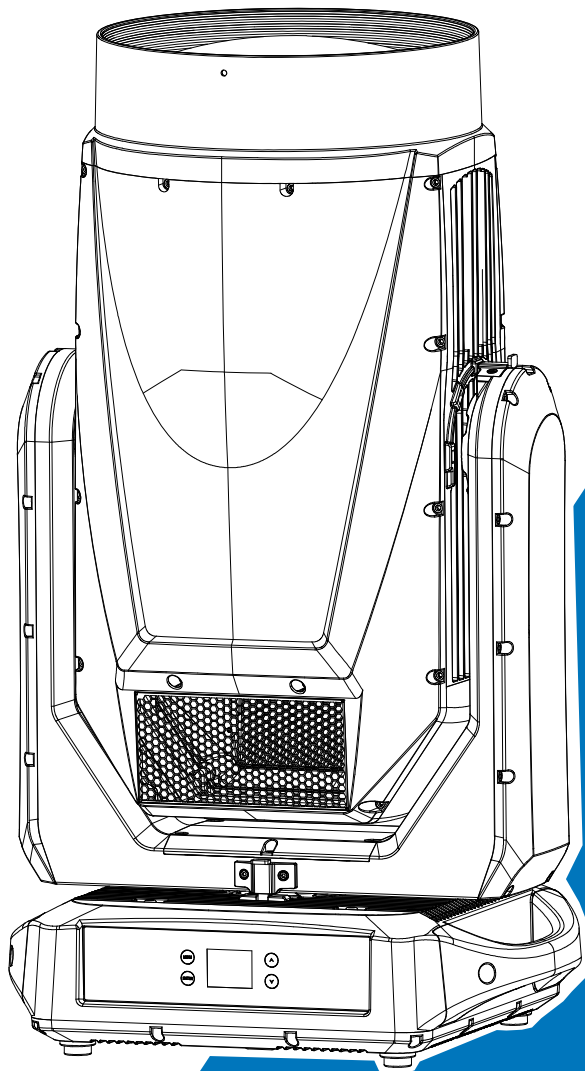

User Manual

Please read the instruction carefully before use

CONTENTS

01/ Safety Information	2
02/ Technical Specifications	4
03/ Overview	6
3.1 Battery Power	7
04/ Connecting Power and Data	9
4.1 Connecting Power	9
4.2 Connecting Data.....	10
05/ Fixture Installation	11
06 Operation	15
6.1 Control Menu	15
6.3 Home Position Adjustment.....	30
07/ Configuring the Device for DMX Control	33
7.1 Address Setting.....	33
7.2 DMX Protocol	34
08/ Error Information	38
09/ Troubleshooting	44
10/ Fixture Cleaning	45

01/ Safety Information



Please read the instruction carefully which includes important information about the installation, usage and maintenance.

WARNING

Please keep this User Manual for future consultation. If you sell the fixture to another user, be sure that they also receive this instruction manual.

Important:

Damages caused by the disregard of this user manual are not subject to warranty. The dealer will not accept liability for any resulting defects or problems.



- Classification: Class 1 laser product (EN/IEC 60825-1:2014) | class 1 risk group 3 (IEC 62471) - Operators shall either restrict access to the beam within the hazard distance, or install the product at a safe distance to avoid eye exposure for spectators.



- Caution: Keep a minimum 10 meters (33 FT) clearance from all lighted objects.



- Eyes Hazard: Do not look directly at operating lamp (EN/IEC 62471) eye injury may result.
- Unpack and check carefully to ensure that there is no transportation damage before using the fixture.
- This product is suitable for wet locations. Do not immerse in water.
- DO install and operate by qualified operator.
- DO NOT allow children to operate the fixture.
- Use safety cable (made of steel, min. diameter 4.0mm) when fixing the fixture. Handle the fixture by carrying its base instead of the head only.
- The fixture must be installed in a location with adequate ventilation, at least 50cm from adjacent surfaces.
- Be sure that no ventilation holes are blocked, otherwise the fixture could over heat.
- Before operation, ensure that you are connecting this product to the proper voltage in

accordance with the specifications in this manual or on the product's specification label.

- It's important to ground the yellow/green conductor to earth in order to avoid electric shock.
- Minimum ambient temperature TA: 0°C. Maximum ambient temperature TA: 75°C. Do not operate this product at a lower or higher temperature.
- DO NOT connect the device to any dimmer pack.
- Keep flammable materials away from the fixture while operating to avoid fire hazard.
- Make sure the power cord is not crimped or damaged; replace it immediately if damaged.
- Fixture's surface temperature may reach up to 50°C. DO NOT touch the housing bare-handed during its operation.

- Avoid any flammable liquids, water or metal from entering the fixture. If it happens, cut off the mains power immediately.
- DO NOT operate in a dirty or dusty environment. DO clean the fixture regularly.
- DO NOT touch any wiring during operation as there might be a hazard of electric shock.
- Avoid entanglement of the power cord with other wires.
- The minimum distance to objects/surface must be more than 80 meters.
- In the event of a serious operating problem, stop using the fixture immediately.
- Never turn the fixture off and on repeatedly.
- The housing, the lenses, or the ultraviolet filter must be replaced if they are visibly damaged.
- DO NOT open the housing as there are no user serviceable parts inside.
- DO NOT attempt to operate this fixture if it becomes damaged. DO NOT attempt any repairs yourself. Repairs carried out by unskilled people can lead to damage or malfunction. Please contact the nearest authorized technical assistance center if needed.
- Disconnect this product from its power source before servicing.
- DO use the original packaging or suitable road case if the device is to be transported.
- Check that the head tilt lock is released before packing for transportation.
- Avoid direct eye exposure to the light source while the product is on.
- DO NOT operate this product if you see damage on the housing, shields, or cables. Have the damaged parts replaced by an authorized technician at once.
- The device MUST NOT be switched on immediately if it has been exposed to strong

temperature fluctuations (e.g. after transport) as condensation may occur inside. Please leave the device switched off until it has reached to ambient temperature.

- External sources of light beams from direct sunlight or any other strong light source, which penetrate the front lens of lighting fixtures, can cause severe internal damage. DO NOT expose the fixture front lens to light beams from direct sunlight or any other strong light source from any angle while unpacking, installation, use, and extended idle times outdoors. DO NOT focus a light beam from one lighting fixture directly towards another.

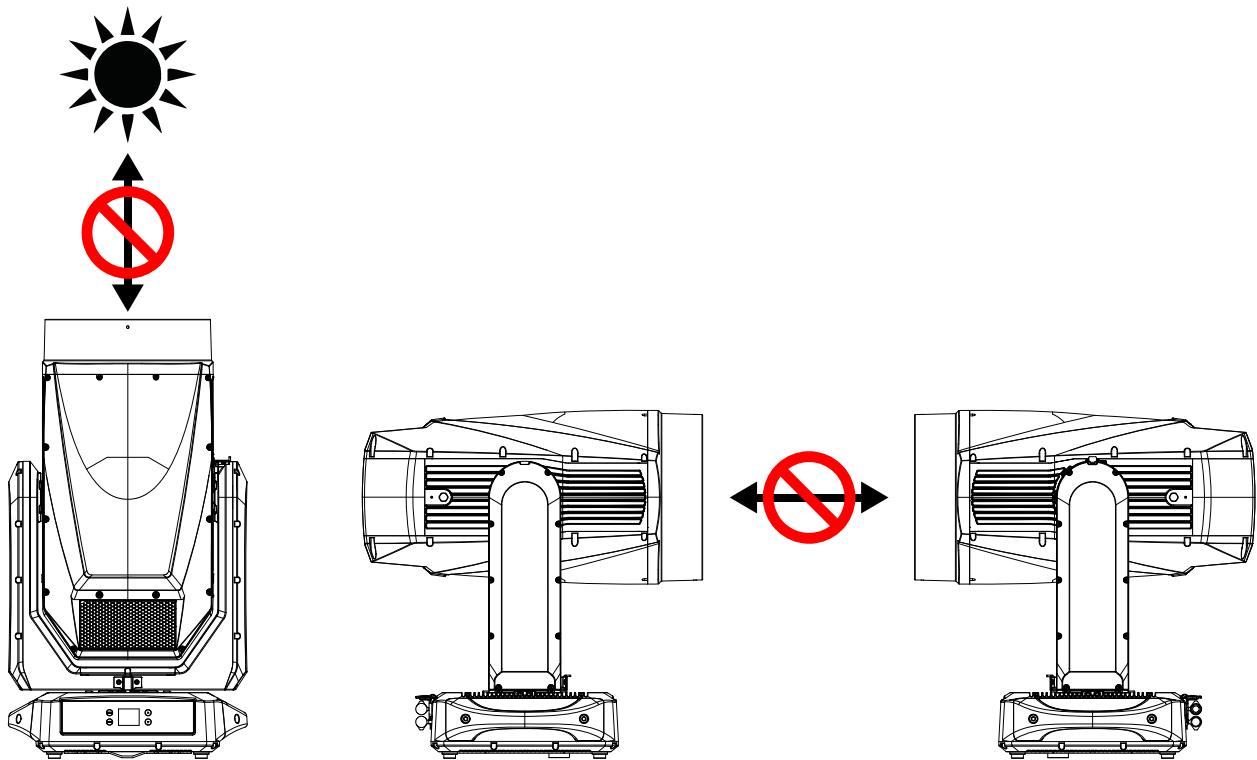

02/ Technical Specifications

AC Power	<u>AC180-240Vac; 50/60Hz</u>
Max. Power Consumption	1585W

Light Source	MBL850-3C	
Color Temperature	7000±500K	
Beam Angle	0.5°	
Movement	Pan	540°
	Tilt	270°
	16 bit movement resolution	
	Automatic pan/tilt repositioning	
	Fixation: Pan/Tilt Lock	
Control and Programming	DMX Channels	23CH/23CH
	Protocols	DMX512
		RDM
		Art-Net
		sACN
Firmware Update	via DMX or USB memory device	
Construction	Display	LCD display
	Battery backup for user setup without mains connection	
	DMX and RDM Data In/Out	5-pin IP XLR (optional with 3-pin IP XLR) RJ45 Connectors
	Power In/Out	Waterproof Power Connector in/out
	Protection Rating	IP66
Dynamic Effects	0-100% continuous dimming and strobe effects	
	4 Dimmer Curve option	
	Variable color temperature control	
	Virtual CMY color mixing	
	4 Prisms, rotatable and over lay able in both directions	
	Linear focus system	
Included Items	Power Cable	
	Two omega brackets with 1/4-turn fasteners	
	User Manual (this document)	
Dimensions	464x365x854mm	18.3"x14.4"x33.6"
Weight	59.5 kg	131.2 lbs

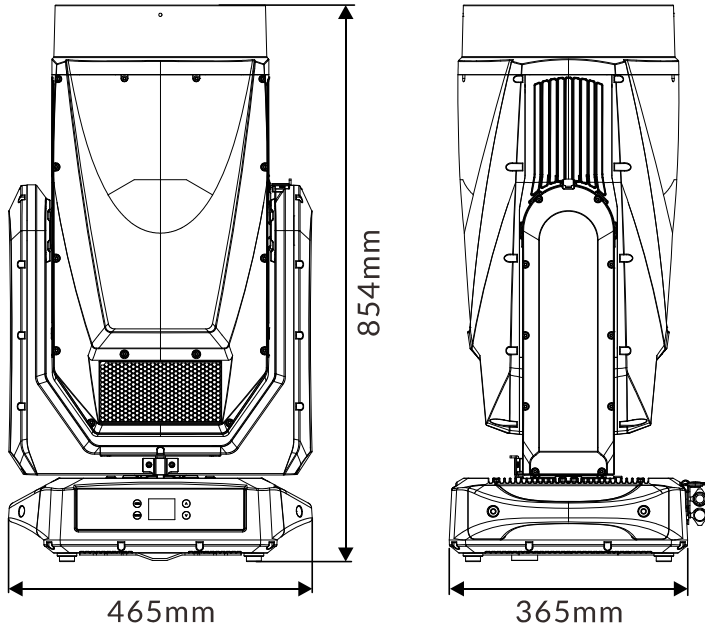

Photometric Diagram:

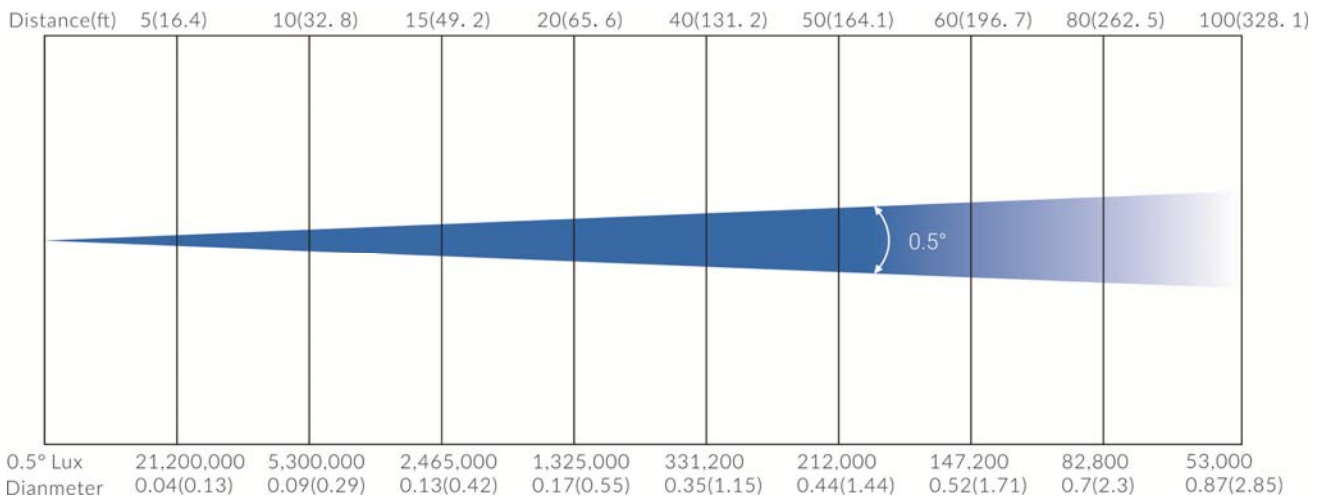

03/ Overview

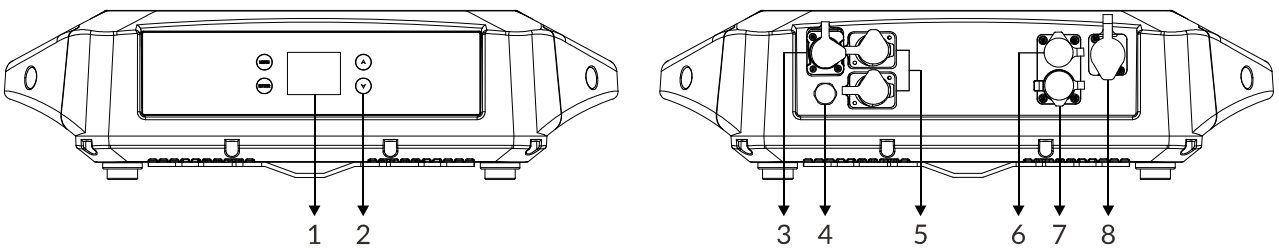

1. Display	To show the various menus and the selected function	
2. Buttons	MENU	To enter into, move backward or leave the menu
	▲ UP	To go backward or move up in the menu
	▼ DOWN	To go forward or move down in the menu
	ENTER	To perform the desired functions
3. FIRMWARE UPGRADE	Used to upgrade fixture's firmware	
4. RELEASE VALVE		
5. ETHERNET	For use with sACN or Art-Net controls	
6. DMX IN	For DMX512 link, use 5-pin XLR cable to link the unit and DMX controller to input DMX signal (optional with 3-pin IP XLR)	
7. DMX OUT	For DMX512 link, use 5-pin XLR cable to link the next units to output DMX signal (optional with 3-pin IP XLR)	
8. POWER IN	To connect to supply power	

3.1 Battery Power

This product contains a rechargeable battery.

Battery type: 14500 Lithium-ion battery (3.7V, 800mAh, 2.9Wh), compliant with the new EU battery regulation EU2023/1542.



Do not expose the fixture or battery to excessive temperatures.

Be aware of the risk of terminals of the battery-operated fixture or battery being short-circuited by metal objects.

This fixture contains battery that is only replaceable by skilled persons.

Different types of batteries or new and used batteries are not to be mixed.

Exhausted batteries are to be removed from the fixture and safely disposed of.

If the fixture is to be stored unused for a long period, the batteries should be removed.

Do not use non-rechargeable batteries in place of rechargeable batteries.

Do not use modified or damaged batteries.

Replacing the battery with an incorrect type can defeat a safeguard and pose a risk of fire or explosion.

Disposal of a battery into fire or a hot oven, or mechanically crushing or cutting of a battery, that can result in an explosion.

Leaving a battery in an extremely high temperature surrounding environment that can result in an explosion or the leakage of flammable liquid or gas.

Using the control panel with battery power:

The fixture contains a battery that enables you to use the control panel to set up the fixture even when it is not connected to the main power supply. The battery charges during fixture operation. All of the main setup options in the control panel are accessible on battery power, but the 'Fixture Test' and 'Reset Function' are not available.

To activate the display when the fixture is not connected to power, press and hold the [▲ UP] button for 3 seconds. The display extinguishes after 30 seconds with no user input. Press and hold the [▲ UP] button for 3 seconds again to re-activate.

Battery Replacement:

Warning! Disconnect the fixture from AC power before replacing its battery. Replace the battery with one of the same type only.

1. Disconnect the fixture from AC mains power and allow to cool.
2. Remove ten screws in the arm cover of the fixture and remove the arm cover.

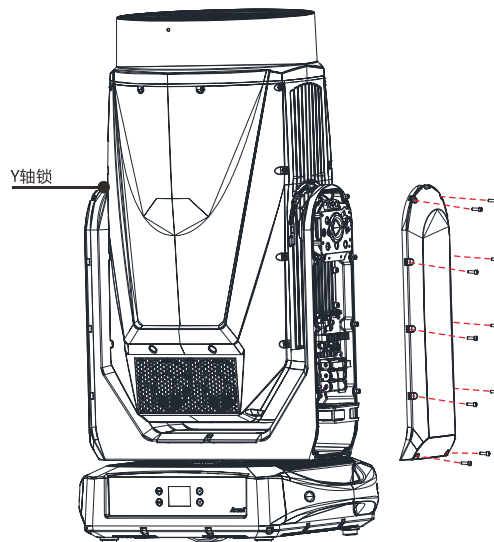

3. Remove two screws of the battery bracket that holds the battery in place and remove the battery bracket.
4. Remove the exhausted battery and insert a new one (only the same type) into the battery holder (Negative (-) towards the spring, Positive (+) away from the spring).

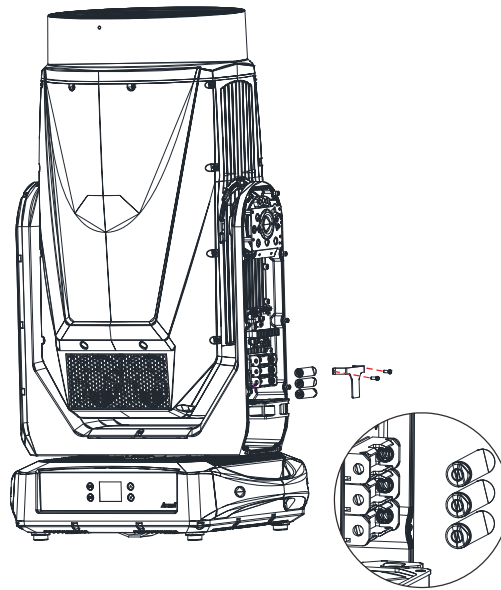

5. Reinstall the battery bracket and the arm cover and check that it is close securely before reapplying power.

04/ Connecting Power and Data

4.1 Connecting Power

To apply power, first check that the head pan and tilt locks are released.

This fixture can operate on any 180-240Vac; 50/60Hz AC mains power supply.

The maximum power consumption is 1585W.

The fixture must be grounded/earthed and able to be isolated from AC power. The AC power supply must incorporate a fuse or circuit breaker for fault protection.

Wiring and connection work must be carried out by a qualified electrician.

The power cable color coding is given in the figure below:

Wire	Color (US)	Wire	Color (EU)	Symbol	Conductor
	black		brown	L	live
	white		blue	N	neutral
	green		yellow/green	\perp or \oplus	ground (earth)

Power cord set that should be used: Listed SJOW flexible cord with rating: 300V, 105°C, VW-1, 16AWG x 3C, molded with 5-15P attachment plug and terminated with cord connector model RCAC3F-X-000-01 with rating 250V, 16A by Neutrik Technology(Ningbo) Co.,Ltd. The power cord shall be at least 914mm (It is to be measured from the face of

attachment plug to the face of connector).

4.2 Connecting Data

The fixture is equipped with 5-pin (or 3-pin) XLR sockets for DMX input and output. Use shielded twisted-pair high-quality DMX cable designed for RS-485 fixtures in order to connect the controller with the fixture and one fixture with another. For outdoor installations, use only waterproof DMX cables suitable for outdoor use.

The default pin-out on XLR sockets is as the following diagram:

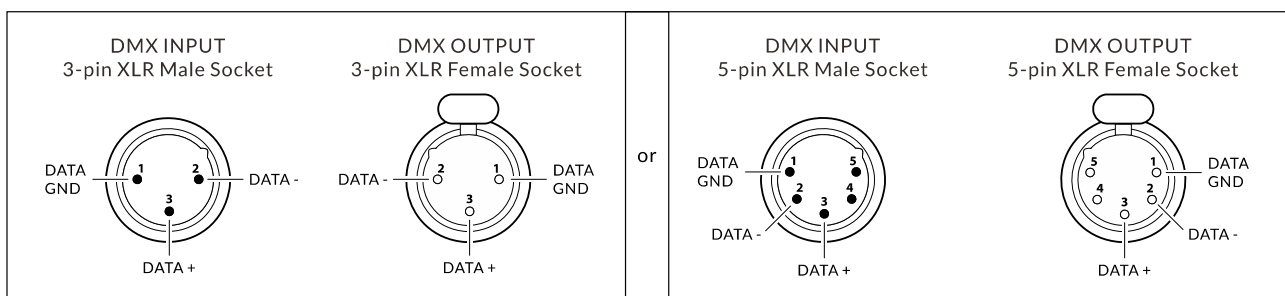

Building a serial DMX chain:

1. Connect the DMX data output from the controller to the fixture's data input socket.
2. Connect the DMX output of the first fixture in the DMX chain with the DMX input of the next fixture. Always connect one output with the input of the next fixture until all fixtures are connected.

Note: Up to 32 fixtures can be connected to the same DMX link.

3. Terminate the DMX output of the last fixture in the data link with a DMX terminator which is an XLR plug with a 120 Ω , 1/4 watt resistor connected between pins 2 and 3.

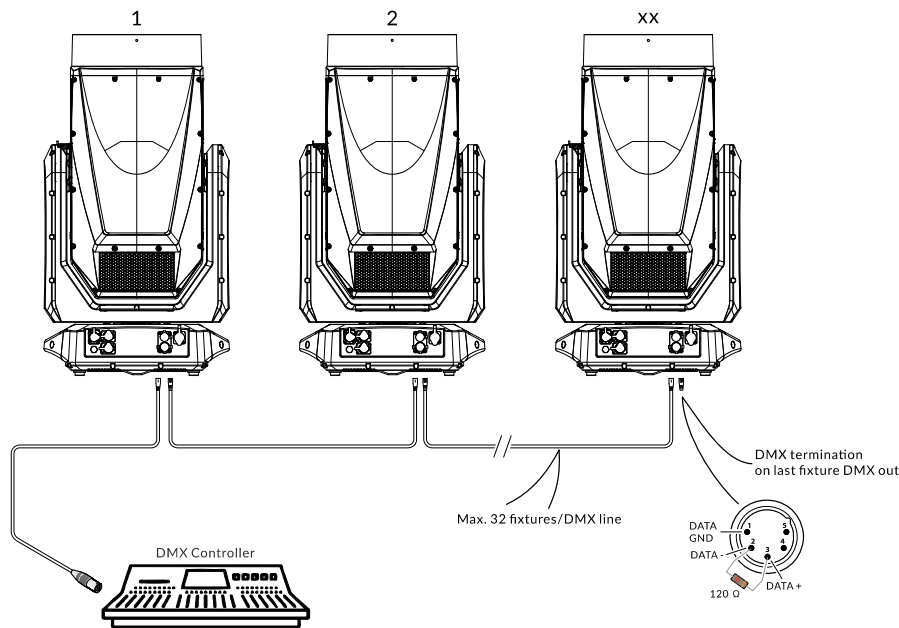

05/ Fixture Installation

The fixture is IP66-rated and designed for both indoor and outdoor events. This means that it is protected from:

- ▶ Dust, to the degree that dust cannot enter the device in sufficient quantities as to interfere with its operation.
- ▶ Water jets from any direction.

DO install and operate by qualified operator. Fixture(s) should be installed in areas outside walking paths, seating areas, or away from areas where unauthorized personnel might reach the fixture by hand. NEVER stand directly below the fixture(s) when rigging, removing or servicing.

Always ensure that the unit is firmly fixed to avoid vibration and slipping off during operation. Ensure that the trussing or area of installation must be able to hold 10 times the weight without any deformation. Always attach a safety cable (made of steel, min. diameter 4.0mm) that can hold at least 12 times the weight of the fixture whenever installing this fixture in a suspended environment to ensure that the fixture will not fall if the clamp fails.

This fixture is fully operational in three different mounting positions: hanging upside-down, mounted sideways on truss, or base positioned on floor. Always use and install a safety cable as a safety measure to prevent accidental damage and/or injury in the event the clamp fails. This fixture is suitable for theaters, studios, and similar locations.

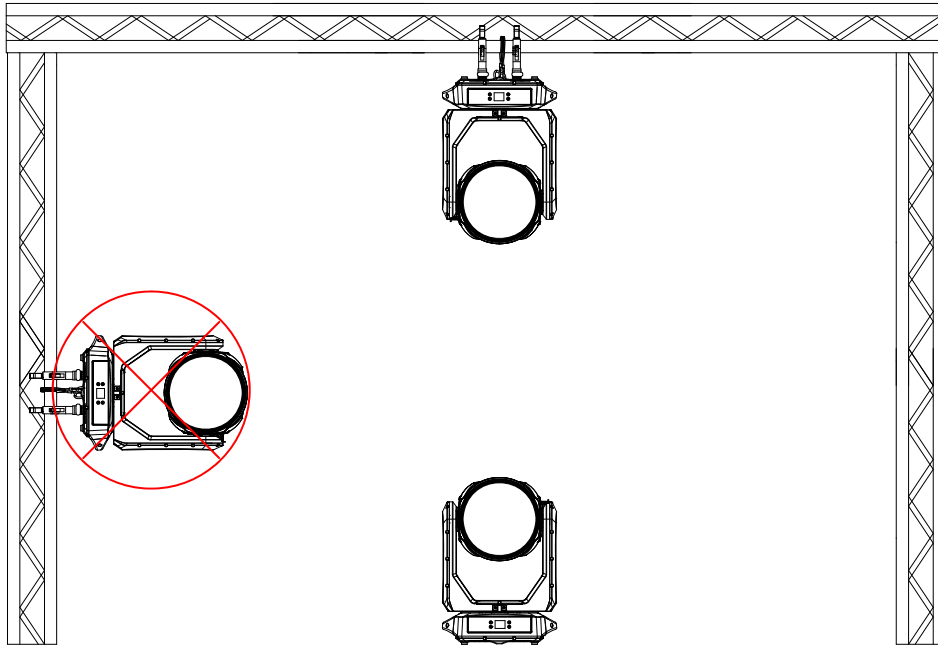

- Use only waterproof power cords and connectors suitable for outdoor use.
- Visually check panel connectors on accidental water leaks and dust before connecting related cable connectors. If some water appears in panel connectors, do not connect cable connectors, especially power!
- Fixtures require regular maintenance. Carefully check panel connectors for corrosion and scorching, and replace them promptly if damaged.
- All power and data connectors are equipped with rubber caps to prevent water ingress. All unused panel connectors have to be sealed by the rubber caps to avoid contact with water, especially seawater.

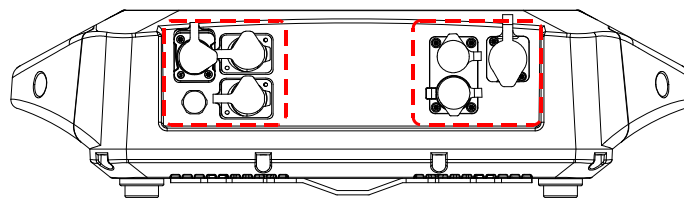

- When routing cables, always bring them into connectors from below. Form a service loop where needed, allowing gravity to divert condensation and water droplets away from the connectors.

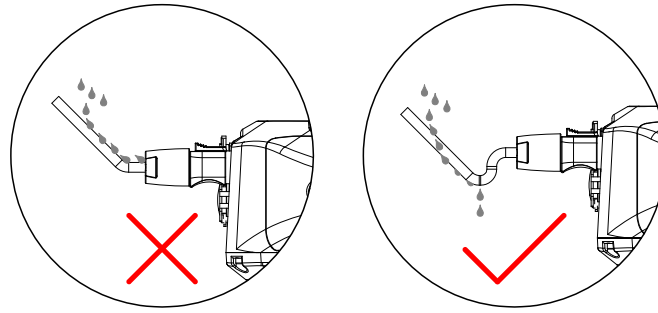

- To ensure the long-term reliable performance of the fixture, it is recommended to perform external cleaning and maintenance every one to two months. Promptly remove corrosive residues such as acidic substances and sea salt deposits attached to the surface of the fixture to slow down the oxidation process of the housing. Additionally, inspect and clean protective grilles and other structures to prevent small organisms like insects from entering the interior, avoiding functional abnormalities or fan blockages caused by the accumulation of insect remains.

Omega Clamp Installation:

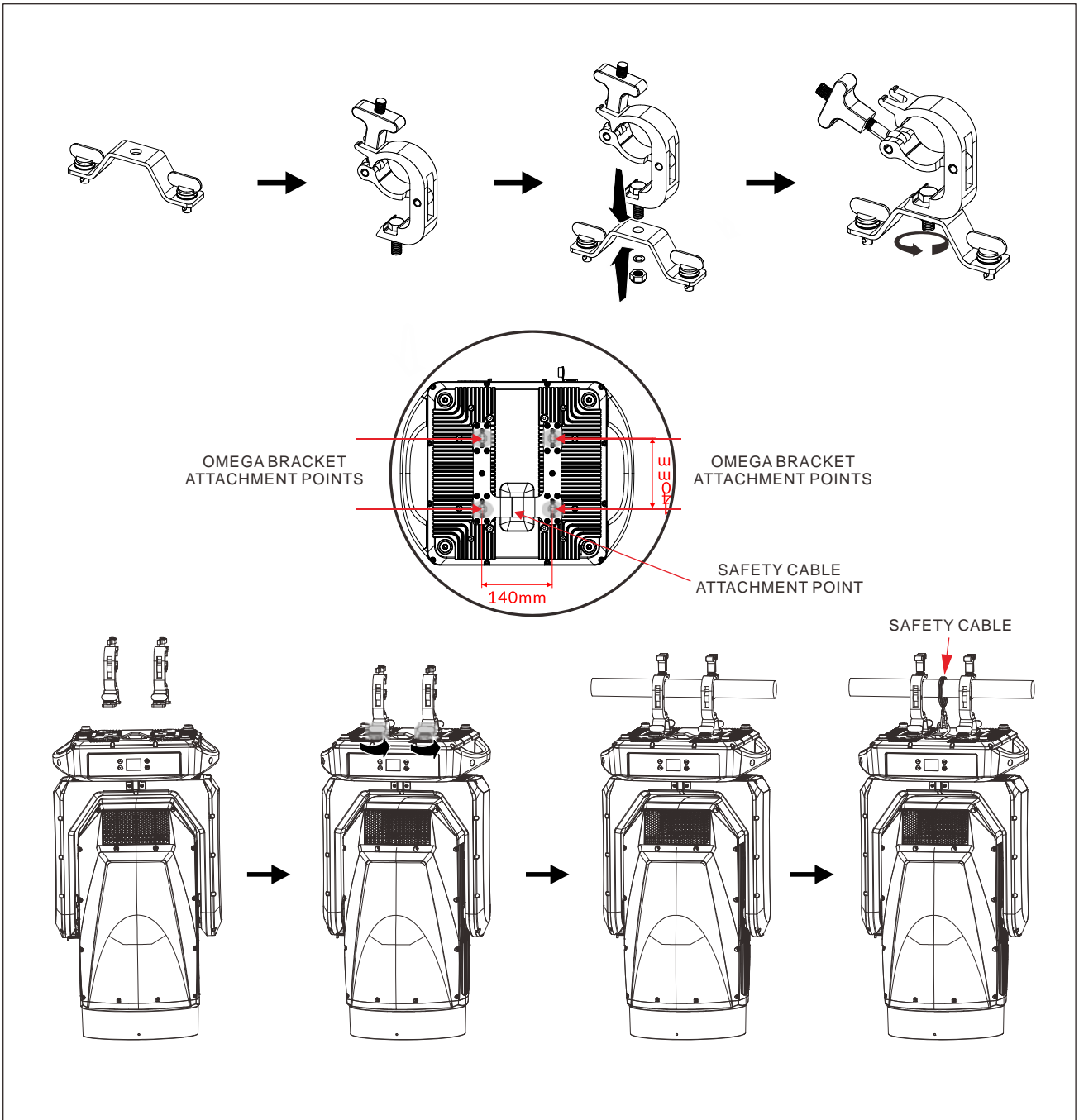

06 Operation

6.1 Control Menu

- ▶ To access the control menus, press the [MENU] button.
- ▶ Navigate the menu structure, using the [ENTER], [▲ UP] and [▼ DOWN] buttons.
- ▶ To select a menu option or to confirm a selection, press the [ENTER] button.
- ▶ To return to a higher level in the menu structure without making a change, press the [MENU] button, or wait 30 seconds.

The screen locks after 30 seconds of inactivity.
Press and hold the [MENU] button to unlock the screen.

The main functions are shown below:

MAIN MENU	SUBMENU	CHOICES/VALUES		
DMX Settings	DMX Address	1-512	(Default=1)	
	DMX Channel Mode	Mode 1(23 ch)		
		Mode 2(23 ch)		
	No DMX Status	Blackout		
		Hold		
		Manual		
	View DMX Value			
	Connect Option	Auto		
		DMX		
		Art-Net		
		sACN		
	Network	IP Address	Default 1:002.xxx.xxx.xxx	
			Default 2:010.xxx.xxx.xxx	
			Manual: xxx.xxx.xxx.xxx	
		Subnet Mask	xxx.xxx.xxx.xxx	
	Art-Net Settings	Net	0-127	(Default=0)
		Subnet	0-15	(Default=0)
Universe		0-15	(Default=0)	
sACN Settings	Universe	1-32000	(Default=1)	
	Priority	0-200	(Default=100)	
Network to DMX	No			
	Yes			
Fixture Settings	Pan Invert	No		

MAIN MENU	SUBMENU	CHOICES/VALUES	
	Tilt Invert	Yes	
		No	
	P/T Feedback	Yes	
		No	
	Pan/Tilt Reset Mode	Standard	
		Sequence	
	Dimmer Speed	Fast	
		Smooth	
	Dimmer Curve	Linear	
		Square Law	
		Inv SQ Law	
		S Curve	
	Cooling Mode	Standard	
		Quiet	
Sun Protection Mode	Off		
	On		
Display Settings	Display Invert	No	
		Yes	
	Backlight Intensity	1-10	(Default=10)
	Temperature Unit	°C	
		°F	
Language	English		
	Chinese		
Fixture Test	Auto Test	Single	
		Cycle	
		Clear	No/Yes
		Pan	0-255
		Tilt	0-255
		RED	0-255
		Red	0-255
		Green	0-255
		Blue	0-255
		CTO	0-255
		Color	0-255
		Prism Tab 1	0-255
		R-Prism 1	0-255
Prism Tab 2	0-255		

MAIN MENU	SUBMENU	CHOICES/VALUES		
		R-Prism 2	0-255	
		Focus	0-255	
		Strobe	0-255	
		Dimmer	0-255	
Fixture Information	Fixture Use Hour			
	LASER Use Hour	Total Laser Hour		
		Laser On Hour		
		Laser Hours Reset	Password=050	
	Humidity	Head	Current	
			Max Humi	
		Base	Current	
			Max Humi	
	Temperature	Laser	Current	
			Max Temp	
	Fan State	B A FAN 1		
		B A FAN 2		
		A B FAN		
		H E FAN 1		
		H E FAN 2		
		H E FAN 3		
		H E FAN 4		
		H E FAN 5		
		H E FAN 6		
		H D FAN 1		
		H C FAN 1		
		H C FAN 2		
		Firmware Version		
RDM UID				
Error Logs	Fixture Errors			
	Reset Error Log	No		
		Yes	Password=050	
Reset Function	Pan/Tilt Reset	No		
		Yes		
	Effect Reset	No		
		Yes		
	All Reset	No		
		Yes		
Special Function	USB Upgrade	No		
		Yes		

MAIN MENU	SUBMENU	CHOICES/VALUES
	Send Upgrade	No
		Yes
	Firmware Restore	No
		Yes
	Factory Settings	No
		Yes

DMX Settings

Enter the control menu and select **DMX Settings**, press ENTER. Use the UP/DOWN button to select **DMX Address**, **DMX Channel Mode**, **No DMX Status**, **View DMX Value**, **Connect Option**, **Network**, **Art-Net Settings**, **sACN Settings** or **Network to DMX**.

DMX Address

Select **DMX Address**, press ENTER.

Use UP/DOWN button to select an address, confirm your selection with ENTER.

CHANNEL MODE	DMX ADDRESS
Mode 1 (23)	1-512
Mode 2 (23)	1-512

To exit the menu, press MENU, or wait 30 seconds.

DMX Channel Mode

Select **DMX Channel Mode**, press ENTER.

Use UP/DOWN button to select between **Mode 1 (23)** and **Mode 2 (23)**, confirm your selection with ENTER.

To exit the menu, press MENU, or wait 30 seconds.

No DMX Status

Select **No DMX Status**, press ENTER.

Use UP/DOWN button to select one of the following status:

Blackout (Fixture blacks out if DMX signal stops)

Hold (The device continues to operate in the current mode with the last active DMX values until the signal returns)

Manual (The device accepts the DMX value stored in the 'Manual Test' menu)

Confirm your selection with ENTER.

To exit the menu, press MENU, or wait 30 seconds.

View DMX Value

Select **View DMX Value**, press ENTER.

Use UP/DOWN button to select the desired DMX channel, for which the value is to be displayed.

To exit the menu, press MENU, or wait 30 seconds.

Connect Option

Select **Connect Option**, press ENTER.

Use UP/DOWN button to select **Auto**, **DMX**, **Art-Net** or **sACN**, confirm your selection with ENTER.

To exit the menu, press MENU, or wait 30 seconds.

Network

Select **Network**, press ENTER.

Use UP/DOWN button to select **IP Address** or **Subnet Mask**, confirm your selection with ENTER.

To exit the menu, press MENU, or wait 30 seconds.

Art-Net Settings

Select **Art-Net Settings**, press ENTER.

Use UP/DOWN button to select **Net**, **Subnet** or **Universe**, confirm your selection with ENTER.

To exit the menu, press MENU, or wait 30 seconds.

sACN Settings

Select **sACN Settings**, press ENTER.

Use UP/DOWN button to select **Universe** or **Priority**, confirm your selection with ENTER.

To exit the menu, press MENU, or wait 30 seconds.

Network to DMX

Select **Network to DMX**, press ENTER.

Use UP/DOWN button to select **No** or **Yes**, confirm your selection with ENTER.

To exit the menu, press MENU, or wait 30 seconds.

Fixture Settings

Enter the control menu and select **Fixture Settings**, press ENTER. Use the UP/DOWN button to select **Pan Invert**, **Tilt Invert**, **P/T Feedback**, **Pan/Tilt Reset mode**, **Dimmer Curve**, **Dimmer Speed**, **Cooling Mode**, **Sun Protection Mode**.

Pan Invert

Select **Pan Invert**, press ENTER.

Use UP/DOWN button to select **No** (pan invert deactivated) or **Yes** (pan invert activated), confirm your selection with ENTER.

To exit the menu, press MENU, or wait 30 seconds.

Tilt Invert

Select **Tilt Invert**, press ENTER.

Use UP/DOWN button to select **No** (tilt invert deactivated) or **Yes** (tilt invert activated), confirm your selection with ENTER.

To exit the menu, press MENU, or wait 30 seconds.

P/T Feedback

Select **P/T Feedback**, press ENTER.

Use UP/DOWN button to select **No** (pan/tilt feedback deactivated) or **Yes** (pan/tilt feedback activated), confirm your selection with ENTER.

To exit the menu, press MENU, or wait 30 seconds.

Pan /Tilt Reset Mode

Select **Pan /Tilt Reset Mode**, press ENTER.

Use UP/DOWN button to select **Standard** or **Sequence** confirm your selection with ENTER.

To exit the menu, press MENU, or wait 30 seconds.

Dimmer Speed

Select **Dimmer Speed**, press ENTER.

Use UP/DOWN button to select **Fast** or **Tugsten**, confirm your selection with ENTER.

To exit the menu, press MENU, or wait 30 seconds.

Dimmer Curve

Select **Dimmer Curve**, press ENTER.

Use UP/DOWN button to select **Linear**, **Square Law**, **Inv SQ Law** or **S Curve**, confirm your selection with ENTER.

Dimmer Modes

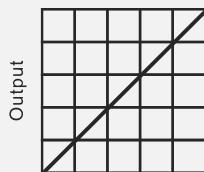

Optically Linear

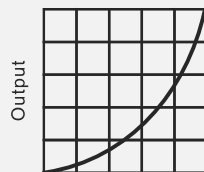

Square Law

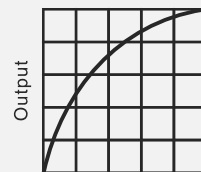

Inverse Square Law

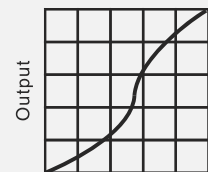

S-curve

To exit the menu, press MENU, or wait 30 seconds.

Cooling Mode

Select **Cooling Mode**, press ENTER.

Use UP/DOWN button to select **Standard** or **Quiet**, confirm your selection with ENTER.

To exit the menu, press MENU, or wait 30 seconds.

Sun Protection Mode

Select **Sun Protection Mode**, press ENTER.

Use UP/DOWN button to select **Off** or **On**, confirm your selection with ENTER.

To exit the menu, press MENU, or wait 30 seconds.

Display Settings

Enter the control menu and select **Display Settings**, press ENTER. Use the UP/DOWN button to select **Display Invert**, **Backlight Intensity**, **Temperature Unit** or **Language**.

Display Invert

Select **Display Invert**, press ENTER.

Use UP/DOWN button to select **No** (display normal) or **Yes** (display inverted), confirm your selection with ENTER.

To exit the menu, press MENU, or wait 30 seconds.

Backlight Intensity

Select **Backlight Intensity**, press ENTER.

Use UP/DOWN button to select a value between **1** (dark) and **10** (bright), confirm your selection with ENTER.

To exit the menu, press MENU, or wait 30 seconds.

Temperature Unit

Select **Temperature Unit**, press ENTER.

Use UP/DOWN button to select **°C** or **°F**, confirm your selection with ENTER.

To exit the menu, press MENU, or wait 30 seconds.

Language

Select **Language**, press ENTER.

Use UP/DOWN button to select **English** or **Chinese**, confirm your selection with ENTER.

To exit the menu, press MENU, or wait 30 seconds.

Fixture Test

Enter the control menu and select **Fixture Test**, press ENTER. Use the UP/DOWN button to select **Auto Test** or **Manual Test**.

Auto Test

Select **Auto Test**, press ENTER.

Use UP/DOWN button to select **Single** (the device immediately performs a single automatic self-test) or **Cycle** (the device immediately performs a cyclic automatic self-test), confirm your selection with ENTER.

To exit the menu, press MENU.

Manual Test

Select **Manual Test**, press ENTER.

Use UP/DOWN button to select the channel for which the manual test is to be performed, confirm your selection with ENTER.

Use UP/DOWN button to select a value, confirm your selection with ENTER.

To exit the menu, press MENU.

(The device returns to its original DMX state after the manual test. The test values are saved automatically when the device is switched off.)

Fixture Information

Enter the control menu and select **Fixture Information**, press ENTER. Use the UP/DOWN button to select **Fixture Use Hour**, **LASER Use Hour**, **Humidity**, **Temperature**, **Fan State**, **Firmware Version**, **RDM UID** or **Error Logs**.

Fixture Use Hour

Select **Fixture Use Hour**, press ENTER.

The operating hours is displayed.

To exit the menu, press MENU, or wait 30 seconds.

LASER Use Hour

Select **LASER Use Hour**, press ENTER.

Use UP/DOWN button to select **Total LASER Hour** (total time) or **LASER On Hour** (current switch-on time), confirm your selection with ENTER.

The total time or current switch-on time is displayed.

Use UP/DOWN button to select **LASER Hours Reset**, confirm your selection with ENTER.

Use UP/DOWN button to set the password 050, confirm your selection with ENTER. The LED operating hours is reset.

To exit the menu, press MENU, or wait 30 seconds.

Humidity

Select **Humidity**, press ENTER.

The device Humidity is displayed.

To exit the menu, press MENU, or wait 30 seconds.

Temperature

Select **Temperature**, press ENTER.

The device Temperature is displayed.

To exit the menu, press MENU, or wait 30 seconds.

Fan State

Select **Fan State**, press ENTER.

The fan status is displayed.

To exit the menu, press MENU, or wait 30 seconds.

Firmware Version

Select **Firmware Version**, press ENTER.

The firmware version is displayed.

To exit the menu, press MENU, or wait 30 seconds.

RDM UID

Select **RDM UID**, press ENTER.

The RDM UID is displayed.

To exit the menu, press MENU, or wait 30 seconds.

Error Logs

Select **Error Logs**, press ENTER.

Use UP/DOWN button to select **Fixture Errors**, confirm your selection with ENTER.

The error list is displayed.

Use UP/DOWN button to select **Reset Error Log**, confirm your selection with ENTER.

If you wish to reset the relevant error logs, select **Yes**. If you do not wish to reset anything, select **No**. Confirm your selection with ENTER.

If you select **Yes**, use UP/DOWN button to set the password 050, confirm your selection with ENTER. The relevant error logs are reset.

To exit the menu, press MENU, or wait 30 seconds.

Reset Function

Enter the control menu and select **Reset Function**, press ENTER. Use the UP/DOWN button to select **Pan/Tilt Reset**, **Effect Reset** or **All Reset**.

Pan/Tilt Reset

Select **Pan/Tilt Reset**, press ENTER.

Use UP/DOWN button to select **No** or **Yes** (the device will run built-in program to reset pan/tilt to their home positions), confirm your selection with ENTER.

To exit the menu, press MENU, or wait 30 seconds.

Effect Reset

Select **Effect Reset**, press ENTER.

Use UP/DOWN button to select **No** or **Yes** (the device will run built-in program to reset effect to their home positions), confirm your selection with ENTER.

To exit the menu, press MENU, or wait 30 seconds.

All Reset

Select **All Reset**, press ENTER.

Use UP/DOWN button to select **No** or **Yes** (the device will run built-in program to reset all to their home positions), confirm your selection with ENTER.

To exit the menu, press MENU, or wait 30 seconds.

Special Function

Enter the control menu and select **Special Function**, press ENTER. Use the UP/DOWN button to select **USB Upgrade**, **Send Upgrade**, **Firmware Restore** or **Factory Settings**.

USB Upgrade

Select **USB Upgrade**, press ENTER.

The upgrade files are displayed. (See the 'Updating Software' section for details.)

To exit the menu, press MENU, or wait 30 seconds.

Send Upgrade

Select **Send Upgrade**, press ENTER.

If you wish to send upgrade files from this fixture to next fixtures to upgrade their firmware, select **Yes**. Once Yes is selected, the display of this fixture will show “**Sending Packet, Please Wait...**” while the display of next fixtures will show “**Upgrading, Please Wait...**”. A percentage bar will also be displayed. After the update is complete, fixtures will perform a reset (this can take some time).

If you do not wish to send anything, select **No**. Confirm your selection with ENTER.

To exit the menu, press MENU, or wait 30 seconds.

Firmware Restore (After replacing fixture's vice board(s), this function allows you to synchronize the main board's software to all vice board(s), as the software version of the replaced vice board(s) may not consistent with that of the main board.)

Select **Firmware Restore**, press ENTER.

If you wish to restore fixture's firmware, select **Yes**. Once Yes is selected, the display will show “**Upgrading, Please Wait...**”. A percentage bar will also be displayed. After the update is complete, the fixture will perform a reset (this can take some time).

If you do not wish to restore anything, select **No**. Confirm your selection with ENTER.

To exit the menu, press MENU, or wait 30 seconds.

Factory Settings

Select **Factory Settings**, press ENTER.

If you wish to reset the device to the factory settings, select **Yes**. If you do not wish to reset anything, select **No**. Confirm your selection with ENTER.

To exit the menu, press MENU, or wait 30 seconds.

RDM functions: Certain menus of the device and functions can be called up via the RDM protocol.

The parameter IDs are implemented as follows for different commands:

Parameter ID	Command 'Discovery'	Command 'Set'	Command 'Get'
DISC_UNIQUE_BRANCH	✓		
DISC_MUTE	✓		
DISC_UN_MUTE	✓		
DEVICE_INFO			✓
SUPPORTED_PARAMETERS			✓
SOFTWARE_VERSION_LABEL			✓
DMX_START_ADDRESS		✓	✓
IDENTIFY_DEVICE		✓	✓
DEVICE_MODEL_DESCRIPTION			✓
PARAMETER_DESCRIPTION			✓
MANUFACTURER_LABEL			✓
DEVICE_LABEL		✓	✓
FACTORY_DEFAULTS		✓	✓
BOOT_SOFTWARE_VERSION_ID			✓
BOOT_SOFTWARE_VERSION_LABEL			✓
DMX_PERSONALITY		✓	✓
DMX_PERSONALITY_DESCRIPTION			✓
SLOT_INFO			✓
SLOT_DESCRIPTION			✓
SENSOR_DEFINITION			✓
SENSOR_VALUE			✓
DEVICE_HOURS			✓
LAMP_HOURS			✓
PAN_INVERT		✓	✓
TILT_INVERT		✓	✓
RESET_DEVICE		✓	✓
CURVE		✓	✓
DMX_STATE		✓	✓
DIMMER_SPEED		✓	✓

√ -Command implemented for the respective parameter ID

6.3 Home Position Adjustment

- ▶ To access the control menus, press the [MENU] button.
- ▶ To access the offset menus, long-press the [ENTER] button.
- ▶ Navigate the offset menus, using the [ENTER], [▲ UP] and [▼ DOWN] buttons.
- ▶ To select a menu option or to confirm a selection, press the [ENTER] button.
- ▶ To return to a higher level in the menu structure without making a change, press the [MENU] button, or wait 30 seconds.

OFFSET MENU	VALUES
Frequency(Hz)	1200
Dimming Start	0-9999
Pan	~128-127
Tilt	~128-127
Prism 1	~128-127
Prism 2	~128-127
Prism 3	~128-127
Prism 4	~128-127
R Prism 1	~128-127
R Prism 2	~128-127
FOCUS	~128-127
Light Shield	~128-127

Frequency(Hz)

Select **Frequency(Hz)**, press ENTER.

Use UP/DOWN button to select a value, confirm your selection with ENTER.

To exit the offset menu, press MENU, or wait 30 seconds.

Dimming Start

Select **Dimming Start**, press ENTER.

Use UP/DOWN button to select a value between 0 and 255, confirm your selection with ENTER.

To exit the offset menu, press MENU, or wait 30 seconds.

Pan

Select **Pan**, press ENTER.

Use UP/DOWN button to select a value between -128 and 127, confirm your selection with ENTER.

To exit the offset menu, press MENU, or wait 30 seconds.

Tilt

Select **Tilt**, press ENTER.

Use UP/DOWN button to select a value between -128 and 127, confirm your selection with ENTER.

To exit the offset menu, press MENU, or wait 30 seconds.

Prism 1

Select **Prism 1**, press ENTER.

Use UP/DOWN button to select a value between -128 and 127, confirm your selection with ENTER.

To exit the offset menu, press MENU, or wait 30 seconds.

Prism 2

Select **Prism 2**, press ENTER.

Use UP/DOWN button to select a value between -128 and 127, confirm your selection with ENTER.

To exit the offset menu, press MENU, or wait 30 seconds.

Prism3

Select **Prism 3**, press ENTER.

Use UP/DOWN button to select a value between -128 and 127, confirm your selection with ENTER.

To exit the offset menu, press MENU, or wait 30 seconds.

Prism 4

Select **Prism 4**, press ENTER.

Use UP/DOWN button to select a value between -128 and 127, confirm your selection with ENTER.

To exit the offset menu, press MENU, or wait 30 seconds.

R-Prism 1

Select **R-Prism 1**, press ENTER.

Use UP/DOWN button to select a value between -128 and 127, confirm your selection with ENTER.

To exit the offset menu, press MENU, or wait 30 seconds.

R-Prism 2

Select **R-Prism 2**, press ENTER.

Use UP/DOWN button to select a value between -128 and 127, confirm your selection with ENTER.

To exit the offset menu, press MENU, or wait 30 seconds.

Focus

Select **Focus**, press ENTER.

Use UP/DOWN button to select a value between -128 and 127, confirm your selection with ENTER.

To exit the offset menu, press MENU, or wait 30 seconds.

Light Shield

Select **Light Shield**, press ENTER.

Use UP/DOWN button to select a value between -128 and 127, confirm your selection with ENTER.

To exit the offset menu, press MENU, or wait 30 seconds.

07/ Configuring the Device for DMX Control

7.1 Address Setting

All fixtures should be given a DMX starting address when operating with a DMX controller, in order to ensure that the correct fixture responds to the correct control signal. Incorrect settings will result in unpredictable responses from the lighting controller.

You can set the same starting address for all fixtures or a group of fixtures, or set different addresses for each individual fixture.

Setting all fixtures to the same DMX address will cause all fixtures to react in the same way. In this case, please note that changing the settings of one channel will affect all the fixtures simultaneously.

If you set each fixture to a different DMX address, each unit will “listen” starting at the channel number you have set, based on the quantity of DMX channels of each fixture. That means changing the settings of one channel will only affect the selected fixture.

For example, if the first fixture is set to 23 ch DMX mode with a start DMX address of 1, the following fixture in the DMX chain should then be set to a DMX address of 24. As the first fixture uses all the first 23 DMX channels, the next available channel is 24 ($23+1=24 >> 24$).

See the chart below for more details:

Channel Mode	Unit 1 Address	Unit 2 Address	Unit 3 Address	Unit 4 Address	Unit xxx Address
23 channels	1	24	47	70
23 channels	1	24	47	70

7.2 DMX Protocol

Valid from firmware version: V1.0

CHANEL		VALUE	FUNCTION
23ch (RGB)	23ch (CMY)		
1	1	000-255	PAN 0°→540°
2	2	000-255	PAN FINE
3	3	000-255	TILE 0°→250°
4	4	000-255	TILT FINE
5	5	000-255	PAN/TILT SPEED Fast to slow
6		000-255	RED 0%→100%
7		000-255	RED FINE 0%→100%
8		000-255	GREEN 0%→100%
9		000-255	GREEN FINE 0%→100%
10		000-255	BLUE 0%→100%
11		000-255	BLUE FINE 0%→100%
	6	000-255	CYAN 0%→100%
	7	000-255	CYAN FINE 0%→100%
	8	000-255	MAGENTA 0%→100%
	9	000-255	MAGENTA FINE 0%→100%
	10	000-255	YELLOW 0%→100%
	11	000-255	YELLOW FINE 0%→100%

12	12	000-255	CTO 8000K-2500K
13	13	000-007	Color Null
		008-009	010 Medium Yellow
		010-011	019 Fire
		012-013	021 Gold Amber
		014-015	025 Sunset Red
		016-017	036 Medium Pink
		018-019	052 Light Lavender
		020-021	058 Lavender
		022-023	068 Sky Blue
		024-025	079 Just Blue
		026-027	088 Lime Green
		028-029	089 Moss Green
		030-031	090 Dark Yellow Green
		032-033	100 Spring Yellow
		034-035	101 Yellow
		036-037	102 Light Amber
		038-039	103 Straw
		040-041	104 Deep Amber
		042-043	105 Orange
		044-045	111 Dark Pink
		046-047	115 Peacock Blue
		048-049	116 Medium Blue-Green
		050-051	117 Steel Blue
		052-053	118 Light Blue
		054-055	120 Deep Blue
		056-057	121 LEE Green
		058-059	122 Fern Green
		060-061	124 Dark Green
		062-063	126 Mauve
		064-065	128 Bright Pink
		066-067	132 Medium Blue
		068-069	135 Deep Golden Amber
070-071	136 Pale Lavender		
072-073	137 Special Lavender		
074-075	138 Pale Green		
076-077	139 Primary Green		
078-079	141 Bright Blue		
080-081	147 Apricot		
082-083	152 Pale Gold		
084-085	157 Pink		

		086-087 088-089 090-091 092-093 094-095 096-097 098-099 100-101 102-103 104-105 106-107 108-109 110-255	162 Bastard Amber 164 Flame Red 165 Daylight Blue 170 Deep Lavender 181 Congo Blue 194 Surprise Pink 197 Alice Blue 201 Full C.T. Blue 202 Half C.T. Blue 353 Lighter Blue 778 Millennium Gold Amber Null
14	14	000-007 008-127 128-255	Prism Tab 1 Off Prism 1 Prism 2
15	15	000-127 128-189 190-193 194-255	R-Prism 1 Index 0°~360° Clockwise Rotation, Fast to Slow Stop Counter-Clockwise Rotation, Slow to Fast
16	16	000-007 008-127 128-255	Prism Tab 2 Off Prism 3 Prism 4
17	17	000-127 128-189 190-193 194-255	R-Prism 2 Index 0°~360° Clockwise Rotation, Fast to Slow Stop Counter-Clockwise Rotation, Slow to Fast
18	18	000-255	FOCUS 0%→100%
19	19	000-255	FOCUS FINE
20	20	000-007 008-015 016-131 132-139 140-181 182-189 190-231	STROBE Close Open Strobe Slow->Fast Open Fast Open Slow Close Open Fast Close Slow Open

		232-239 240-247 248-255	Open Random Strobe Slow >Fast Open
21	21	000-255	DIMMER 0%→100%
22	22	000-255	DIMMER FINE 0%→100%
23	23	000-029 030-039 040-049 050-059 060-069 070-079 080-089 090-099 100-109 110-119 120-139 140-149 150-159 160-199 200-209 210-219 220-229 230-239 240-241 242-243 244-245 246-255	FUNCTION No Function Dimmer Curve Linear Dimmer Curve Square Law Dimmer Curve Inv Square Law Dimmer Curve S Fan Mode Standard Fan Mode Quiet No Function No Function No Function No Function Pan/tilt Reset Effect Reset No Function Reset all Dimmer Speed Fast Dimmer Speed Smooth No Function No Function Sun Protection Mode : On Sun Protection Mode : Off No Function

08/ Error Information

Error codes are shown continuously in the display when the fixture fails and they will not disappear until the fixture is repaired.

CPU-B/C/D/E/F/G Error

Check whether the 485 (DATA) leads on the PCB board are installed in place or disconnected.

Check whether the related 485 (DATA) signal circuit on the PCB board is damaged.

Laser Timeout Use

Laser Too Hot Off

When the fixture temperature reaches 75°C, it will automatically turn off to protect the fixture.

Pan Reset Error

Check whether the position of the pan where the magnet is installed falls off or is damaged.

Check whether there are obstacles in the pan operating range.

Check whether the Hall element on the pan is damaged.

Check whether the lead connecting the Hall element on the pan and the PCB board is in poor contact or disconnected.

Check whether the motor on the pan is damaged.

Check whether the related circuit of the motor drive board on the pan is damaged.

Pan Encode Error

Check whether the encoder on the pan is damaged.

Check whether the lead connecting the encoder on the pan and the PCB board is in poor contact or disconnected.

Pan Encode No Find

Check whether the lead connecting the encoder on the pan and the PCB board is in poor contact or disconnected.

Pan Encode Disable

Check whether the encoder on the pan is damaged.

Tilt Reset Error

Check whether the position of the tilt where the magnet is installed falls off or is damaged.

Check whether there are obstacles in the tilt operating range.

Check whether the Hall element on the tilt is damaged.

Check whether the lead connecting the Hall element on the tilt and the PCB board is in poor contact or disconnected.

Check whether the motor on the tilt is damaged.

Check whether the related circuit of the motor drive board on the tilt is damage.

Tilt Encode Error

Check whether the encoder on the tilt is damaged.

Check whether the lead connecting the encoder on the tilt and the PCB board is in poor contact or disconnected.

Tilt Encode No Find

Check whether the lead connecting the encoder on the tilt and the PCB board is in poor contact or disconnected.

Tilt Encode Disable

Check whether the encoder on the tilt is damaged.

Prism 1/2/3/4 Reset Fail

Check whether the position of the prism where the magnet is installed falls off or is damaged.

Check whether there are obstacles in the prism operating range.

Check whether the Hall element on the prism is damaged.

Check whether the lead connecting the Hall element on the prism and the PCB board is in poor contact or disconnected.

Check whether the motor on the prism is damaged.

Check whether the related circuit of the motor drive board on the prism is damage.

R-Prism 1/2 Reset Error

Check whether the position of the R-prism 1/2 where the magnet is installed falls off or is damaged.

Check whether there are obstacles in the R-prism 1/2 operating range.

Check whether the Hall element on the R-prism 1/2 is damaged.

Check whether the lead connecting the Hall element on the R-prism 1/2 and the PCB board is in poor contact or disconnected.

Check whether the motor on the R-prism 1/2 is damaged.

Check whether the related circuit of the motor drive board on the

Focus Reset Error

Check whether the position of the focus where the magnet is installed falls off or is damaged.

Check whether there are obstacles in the focus operating range.

Check whether the Hall element on the focus is damaged.

Check whether the lead connecting the Hall element on the focus and the PCB board is in poor contact or disconnected.

Check whether the motor on the focus is damaged.

Check whether the related circuit of the motor drive board on the focus is damage.

Base Fan 1/2 Start Err

Check whether the fan is not running.

Check whether the fan leads are installed in place or disconnected.

Check whether the fan is damaged.

Check whether there are obstacles in the fan operating range.

Arm Fan 1 Start Err

Check whether the fan is not running.

Check whether the fan leads are installed in place or disconnected.

Check whether the fan is damaged.

Check whether there are obstacles in the fan operating range.

Head Fan 1/2/3/4/5/6 Start Err

Check whether the fan is not running.

Check whether the fan leads are installed in place or disconnected.

Check whether the fan is damaged.

Check whether there are obstacles in the fan operating range.

Base Humidity Error

Check whether the humidity sensor is faulty.

Check whether the lead connecting the humidity sensor is installed in place or disconnected.

Base Humi. Too High

Disassemble the housing of the fixture to dehumidify.

Memory Error

When the memory IC keeps reporting errors, please replace the motherboard.

CPU A G Sensor Error

When the CPU A G Sensor keeps reporting errors, please replace the motherboard.

Network Error

When the Network keeps reporting errors, please replace the motherboard.

External Flash Error

When the External Flash keeps reporting errors, please replace the motherboard.

Color Cal IC Error

When the Color Cal IC keeps reporting errors, please replace the motherboard.

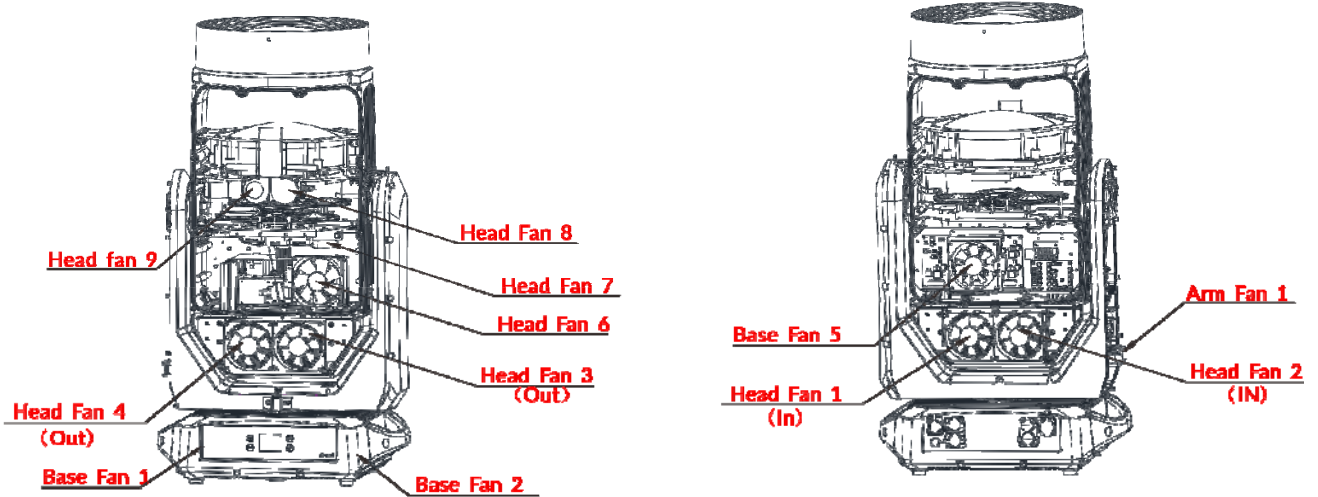

Cooling Fans	Part Number	V	W	Posion
Base Fan 1	3014001256	DC 24V	4.8W	Base-A
Base Fan 2				
Arm Fan1	3014001426	DC 24V	8.4W	Arm-B
Head Fan 1 (In)	3014001399	DC 24V	12.48W	Head-E
Head Fan 2 (In)				
Head Fan 3 (Out)				
Head Fan 4 (Out)				
Head Fan 5	3014001264	DC 24V	4.8W	
Head Fan 6				
Head Fan 7	3014001300	DC 24V	2.88W	Head-D
Head Fan 8				DC 24V
Head Fan 9				

09/ Troubleshooting

Problem	Potential cause(s)	Remedies
Fixture does not respond or appears to be off.	No power to the fixture.	Confirm that the power is switched on and cables are plugged in.
	No output from PSU.	Replace the PSU.
Fixture suddenly turned off.	Power was turned off.	Check the power supply, switches and breakers.
Light output cuts out intermittently.	Fixture is too hot.	Check fixture's stored error messages for more information. Allow fixture to cool. Clean fixture. Reduce ambient temperature.
Fixture suddenly stopped responding.	DMX cables were disconnected.	Inspect DMX cables.
Fixture operates irregularly / abnormal.	Incorrect DMX address or DMX mode.	Inspect and enter the correct DMX address or mode.
	DMX link is not terminated.	Install a XLR 120ohm DMX termination at the end of the DMX link.
	Bad data link.	Replace or repair defective cables and/or connections.
	One of the fixtures is defective and is disturbing data transmission on the link.	Track and isolate the corrupted fixture. Have the fixture serviced by a qualified technician.
Pan / tilt is skipping / shuddering	Pan/ tilt locks are not released.	Release the pan / tilt locks.
	Obstacles are within the required pan / tilt clearance.	Inspect and remove any obstacles constraining free operation of the pan / tilt.
	The Hall element is damaged.	Replace the Hall element.
	The magnetic steel fell out.	Replace the magnetic steel.

10/ Fixture Cleaning

Regular cleaning is very important for fixture life and performance. Buildup of dust, dirt, smoke particles, fog fluid residues, etc. degrades the fixture's light output and cooling ability. Cleaning schedules for lighting fixtures vary greatly depending on the operating environment. It is therefore impossible to specify precise cleaning intervals for the fixture. Environmental factors that may result in a need for frequent cleaning include:

- ▶ Use of smoke or fog machines.
- ▶ High airflow rates (near air conditioning vents, for example).
- ▶ Airborne dust (from stage effects, building structures and fittings or the natural environment at outdoor events, for example).

If one or more of these factors is present, inspect fixtures within their first few hours of operation to see whether cleaning is necessary. Check again at frequent intervals. This procedure will allow you to assess cleaning requirements in your particular situation.

Follow these precautions when cleaning the fixture:

- ▶ Work in a clean, dry, well-lit area.
- ▶ Use gentle pressure only. A soft lint-free cloth dampened with a solution of water and a mild detergent is recommended, under no circumstances should alcohol, solvents or abrasives be used! Use care when cleaning optical components: surfaces are fragile and easily scratched.



www.acmelighting.com