

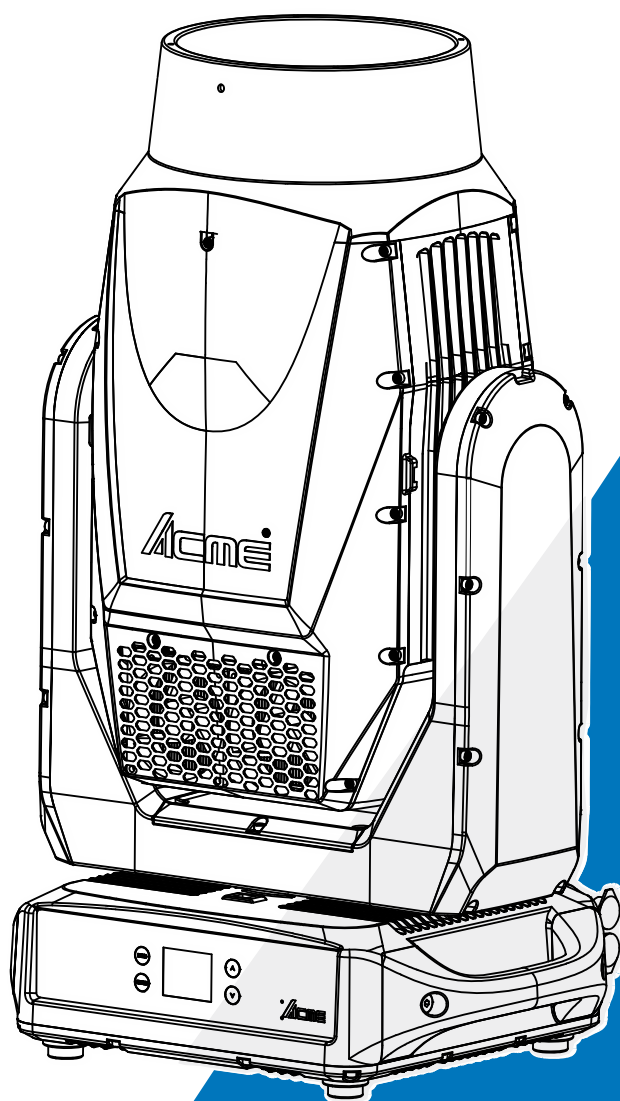

PHOTON HYBRID 500



User Manual

Please read the instruction carefully before use

CONTENTS

01/ Safety Information.....	2
02/ Technical Specifications	6
03/ Overview	8
3.1 Battery Power	9
04/ Connecting Power and Data	11
4.1 Connecting Power	11
4.2 Connecting Data.....	12
05/ Fixture Installation.....	13
06/ Effect Wheels & Lamp	16
6.1 Effect Wheels.....	16
6.2 Light Source.....	20
6.3 Lamp Replacement Warning.....	21
07/ Operation	22
7.1 Control Menu.....	22
7.2 Updating Software.....	36
7.3 Home Position Adjustment.....	39
08/ Configuring the Device for DMX Control.....	44
8.1 Address Setting.....	44
8.2 DMX Protocol	45
09/ Error Information	51
10/ Troubleshooting.....	61
11/ Fixture Cleaning	62
12/ Approvals and Certifications.....	63

01/ Safety Information



Please read the instruction carefully which includes important information about the installation, usage and maintenance.

WARNING

Please keep this User Manual for future consultation. If you sell the unit to another user, be sure that they also receive this instruction manual.

Important:

Damages caused by the disregard of this user manual are not subject to warranty. The dealer will not accept liability for any resulting defects or problems.



- Classification: Class 1 laser product (EN/IEC 60825-1:2014) | class 1 risk group 3 (IEC 62471) - Operators shall either restrict access to the beam within the hazard distance, or install the product at a safe distance to avoid eye exposure for spectators.



- Caution: Keep a minimum 10 meters (33 FT) clearance from all lighted objects.



- Eyes Hazard: Do not look directly at operating lamp (EN/IEC 62471) eye injury may result.

- Unpack and check carefully to ensure that there is no transportation damage before using the unit.
- This product is suitable for wet locations. Do not immerse in water.
- DO install and operate by qualified operator.
- DO NOT allow children to operate the fixture.
- Use safety chain when fixing the unit. Handle the unit by carrying its base instead of the head only.
- The unit must be installed in a location with adequate ventilation, at least 50cm from adjacent surfaces.
- Be sure that no ventilation holes are blocked, otherwise the unit could over heat.

- Before operation, ensure that you are connecting this product to the proper voltage in accordance with the specifications in this manual or on the product's specification label.
- It's important to ground the yellow/green conductor to earth in order to avoid electric shock.
- Minimum ambient temperature TA: 0°C. Maximum ambient temperature TA: 40°C. Do not operate this product at a lower or higher temperature.
- DO NOT connect the device to any dimmer pack.
- During initial start-up some smoke or smell may arise. This is a normal process and does not necessarily mean that the device is defective, and it will decrease gradually within 15 minutes.
- Keep flammable materials away from the fixture while operating to avoid fire hazard.
- Make sure the power cord is not crimped or damaged; replace it immediately if damaged.
- Unit's surface temperature may reach up to 75°C. DO NOT touch the housing bare-handed during its operation.
- Avoid any flammable liquids, water or metal from entering the unit. If it happens, cut off the mains power immediately.
- DO NOT operate in a dirty or dusty environment. DO clean the fixture regularly.
- DO NOT touch any wiring during operation as there might be a hazard of electric shock.
- Avoid entanglement of the power cord with other wires.
- The minimum distance to objects/surface must be more than 12 meters.
- Disconnect mains power before lamp replacement or servicing.
- Replace lamp only with the same type.
- In the event of an operating problem, stop using the unit immediately.
- Never turn the unit off and on repeatedly.
- The housing, the lenses, or the ultraviolet filter must be replaced if they are visibly damaged.
- DO NOT open the housing as there are no user serviceable parts inside.
- DO NOT attempt to operate this unit if it becomes damaged. DO NOT attempt any repairs yourself. Repairs carried out by unskilled people can lead to damage or malfunction. Please contact the nearest authorized technical assistance center if needed.
- Disconnect this product from its power source before servicing.
- DO use the original packaging or suitable road case if the device is to be transported.

- Check that the head tilt lock is released before packing for transportation.
 - Hot lamp explosion hazard. DO NOT open the unit within 15 minutes after switching off.
 - DO replace the bulb once it is damaged, deformed or life-expired.
 - Avoid direct eye exposure to the light source while the product is on.
 - Never touch bulb with bare fingers, as it is very hot after using.
 - DO NOT operate this product if you see damage on the housing, shields, or cables. Have the damaged parts replaced by an authorized technician at once.
 - The device MUST NOT be switched on immediately if it has been exposed to strong temperature fluctuations (e.g. after transport) as condensation may occur inside. Please leave the device switched off until it has reached to ambient temperature.
-
- External sources of light beams from direct sunlight or any other strong light source, which penetrate the front lens of lighting fixtures, can cause severe internal damage. DO NOT expose the fixture front lens to light beams from direct sunlight or any other strong light source from any angle while unpacking, installation, use, and extended idle times outdoors. DO NOT focus a light beam from one lighting fixture directly towards another.

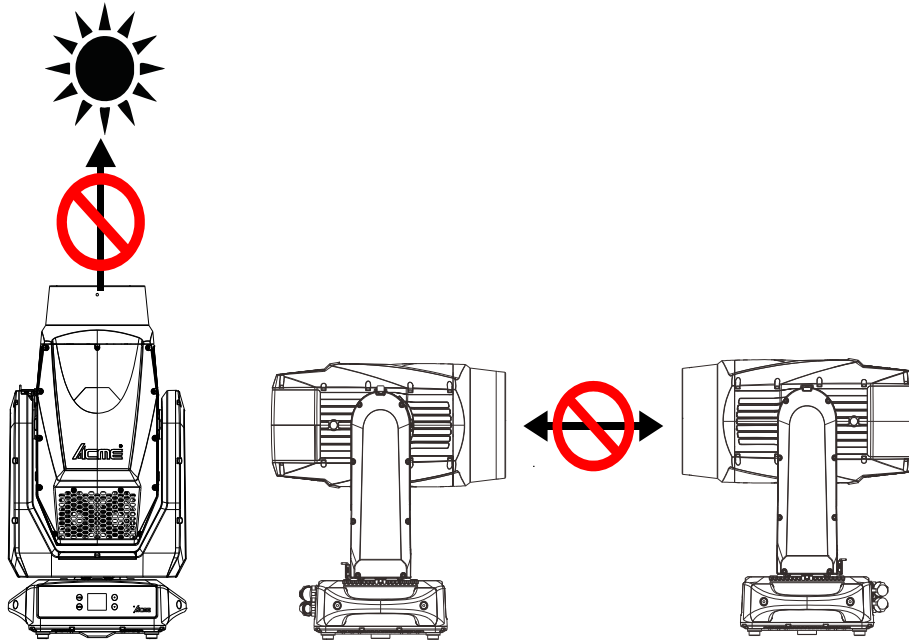

02/ Technical Specifications

AC Power	100-240Vac; 50/60Hz	
Max. Power Consumption	660W	
Light Source	BLL350A-95-R00-000	
Color Temperature	8000K	
Beam Angle	0.9°-22°	
Color Wheels	Color Wheel	16 colors + CRI + open
Gobo Wheels	Static Gobo Wheel	21 gobos + open
	Rotating Gobo Wheel	11 replaceable gobos + open
Movement	Pan	540°
	Tilt	270°
	16 bit movement resolution	
	Automatic pan/tilt repositioning	
	Mechanical pan/tilt lock for safe transportation and maintenance	
Control and Programming	DMX Channels	28/31
	Protocols	DMX512
		RDM
		Art-Net
		sACN
	Firmware Update	via DMX or USB memory device
Construction	Display	LCD display
	Battery backup for user setup without mains connection	
	DMX and RDM Data In/Out	5-pin IP XLR (optional with 3-pin IP XLR)
		RJ45 Connectors
	Power In/Out	Waterproof Power Connector in/out
	Protection Rating	IP66 (Warning: Do not immerse the vent valve in water.)
Dynamic Effects	Choice of four dimming curves	
	CMY color mixing	
	Variable color temperature control	
	4 Prisms: 4-facet circular prism, 8-facet circular prism, 4-facet linear prism, 6-facet linear prism, enabling 2 x 2 prism overlay effects	
	Frost: Variable 0%-100%	
	IP66 rated	
	Motorized focus	

	A soft filter	
Dimensions	380x284x679mm	14.9"x11.2"x26.7"
Weight	33.5kg	73.9 lbs

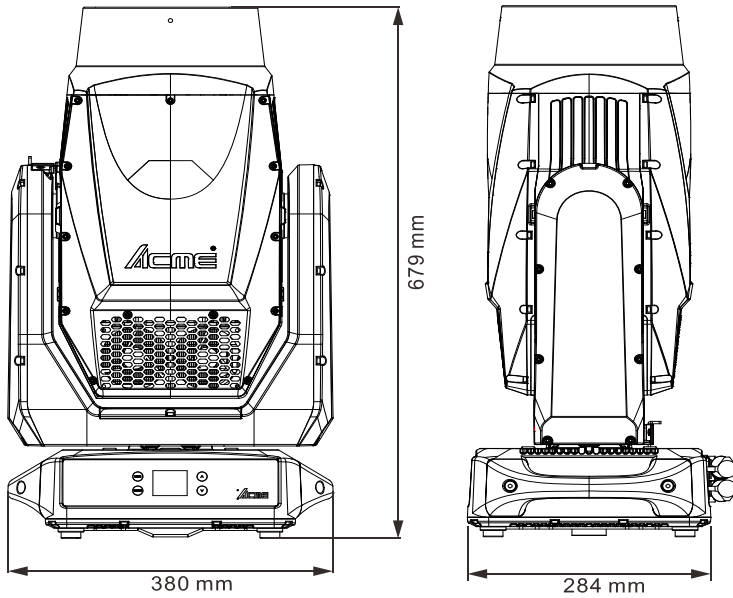

Photometric Diagram:

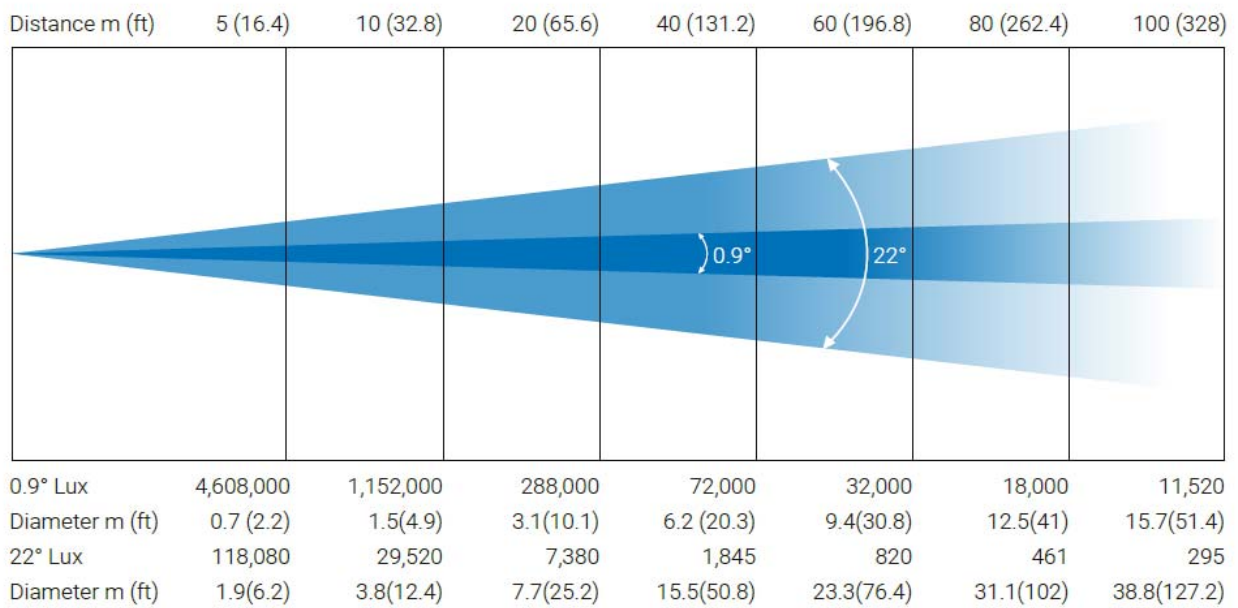

03/ Overview

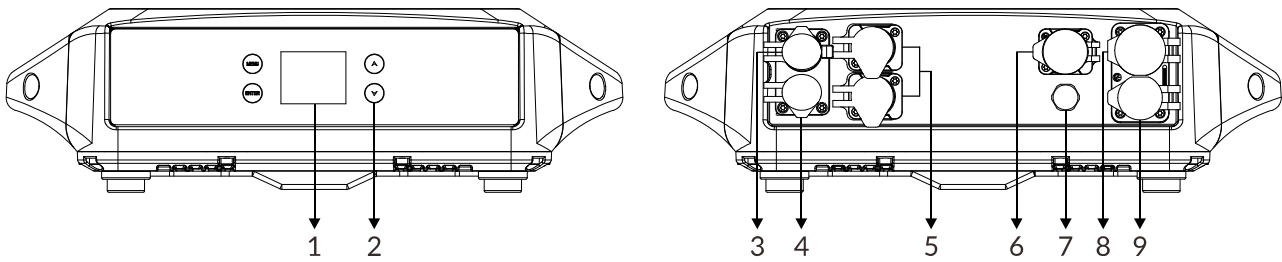

1. Display	To show the various menus and the selected function	
2. Buttons	MENU	To enter into, move backward or leave the menu
	▲ UP	To go backward or move up in the menu
	▼ DOWN	To go forward or move down in the menu
	ENTER	To perform the desired functions
3. DMX OUT	For DMX512 link, use 5-pin XLR cable to link the next units to output DMX signal (optional with 3-pin IP XLR)	
4. DMX IN	For DMX512 link, use 5-pin XLR cable to link the unit and DMX controller to input DMX signal (optional with 3-pin IP XLR)	
5. ETHERNET	For use with sACN or Art-Net controls	
6. FIRMWARE UPGRADE	Used to upgrade the fixture's firmware	
7. RELEASE VALVE		
8. POWER OUT	To connect to the next fixture	
9. POWER IN	To connect to supply power	

3.1 Battery Power

This product contains a rechargeable battery.

Battery type: 14500 Lithium-ion battery*3 (3.7V, 2200mAh, 8.14Wh), compliant with the new EU battery regulation EU2023/1542.



Do not expose the fixture or battery to excessive temperatures.

Be aware of the risk of terminals of the battery-operated fixture or battery being short-circuited by metal objects.

This fixture contains battery that is only replaceable by skilled persons.

Different types of batteries or new and used batteries are not to be mixed.

Exhausted batteries are to be removed from the fixture and safely disposed of.

If the fixture is to be stored unused for a long period, the batteries should be removed.

Do not use non-rechargeable batteries in place of rechargeable batteries.

Do not use modified or damaged batteries.

Replacing the battery with an incorrect type can defeat a safeguard and pose a risk of fire or explosion.

Disposal of a battery into fire or a hot oven, or mechanically crushing or cutting of a battery, that can result in an explosion.

Leaving a battery in an extremely high temperature surrounding environment that can result in an explosion or the leakage of flammable liquid or gas.

Using the control panel with battery power:

The fixture contains a battery that enables you to use the control panel to set up the fixture even when it is not connected to the main power supply. The battery charges during fixture operation. All of the main setup options in the control panel are accessible on battery power, but the 'Fixture Test' and 'Reset Function' are not available.

To activate the display when the fixture is not connected to power, press and hold the [▲ UP] button for 3 seconds. The display extinguishes after 30 seconds with no user input. Press and hold the [▲ UP] button for 3 seconds again to re-activate.

Battery Replacement:

Warning! Disconnect the fixture from AC power before replacing its battery. Replace the battery with one of the same type only.

1. Disconnect the fixture from AC mains power and allow to cool.
2. Remove eight screws in the arm cover of the fixture and remove the arm cover.

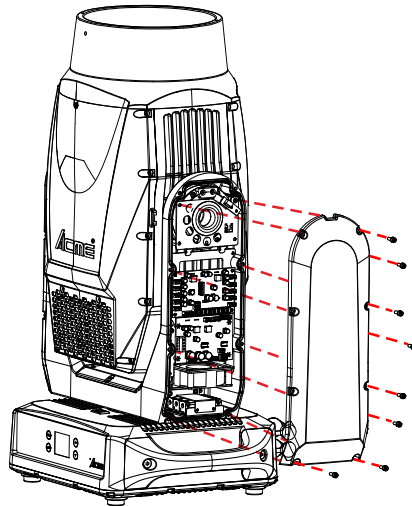

3. Remove two screws of the battery bracket that holds the battery in place and remove the battery bracket.
4. Remove the exhausted battery and insert a new one (only the same type) into the battery holder (Negative (-) towards the spring, Positive (+) away from the spring).

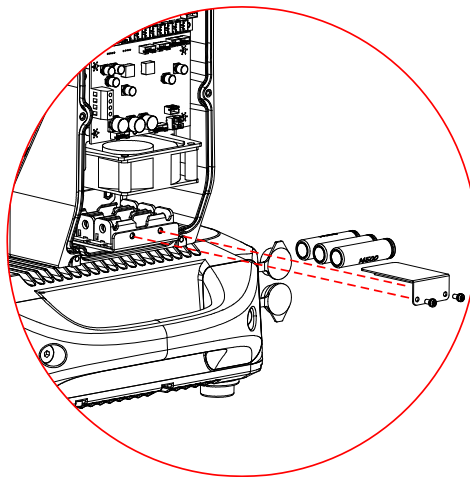

5. Reinstall the battery bracket and the arm cover and check that it is close securely before reapplying power.

04/ Connecting Power and Data

4.1 Connecting Power

To apply power, first check that the head pan and tilt locks are released.

This fixture can operate on any 100-240Vac; 50/60Hz AC mains power supply.

The maximum power consumption is 660W.

The fixture must be grounded/earthed and able to be isolated from AC power. The AC power supply must incorporate a fuse or circuit breaker for fault protection.

Wiring and connection work must be carried out by a qualified electrician.

The power cable color coding is given in the figure below:

Wire	Color (US)	Wire	Color (EU)	Symbol	Conductor
	black		brown	L	live
	white		blue	N	neutral
	green		yellow/green	\perp or \oplus	ground (earth)

CAUTION!

DO NOT CONNECT THE FIXTURE TO AN ELECTRICAL DIMMER SYSTEM AS DOING SO MAY CAUSE DAMAGE.

4.2 Connecting Data

The fixture is equipped with 5-pin (or 3-pin) XLR sockets for DMX input and output. Use a high-quality DMX cable designed for RS-485 and 5-pin (or 3-pin) XLR-plugs and connectors in order to connect the controller with the fixture or one fixture with another. For outdoor installations, use only IP-rated XLR connectors suitable for outdoor use.

Building a serial DMX chain:

Connect the DMX data output from the controller to the fixture's data input socket. Connect the DMX output of the first fixture in the DMX chain with the DMX input of the next fixture. Always connect one output with the input of the next fixture until all fixtures are connected. Up to 32 fixtures can be connected to the same DMX link. Terminate the DMX out cable of the last fixture in the data link with a 120 ohm DMX terminator.

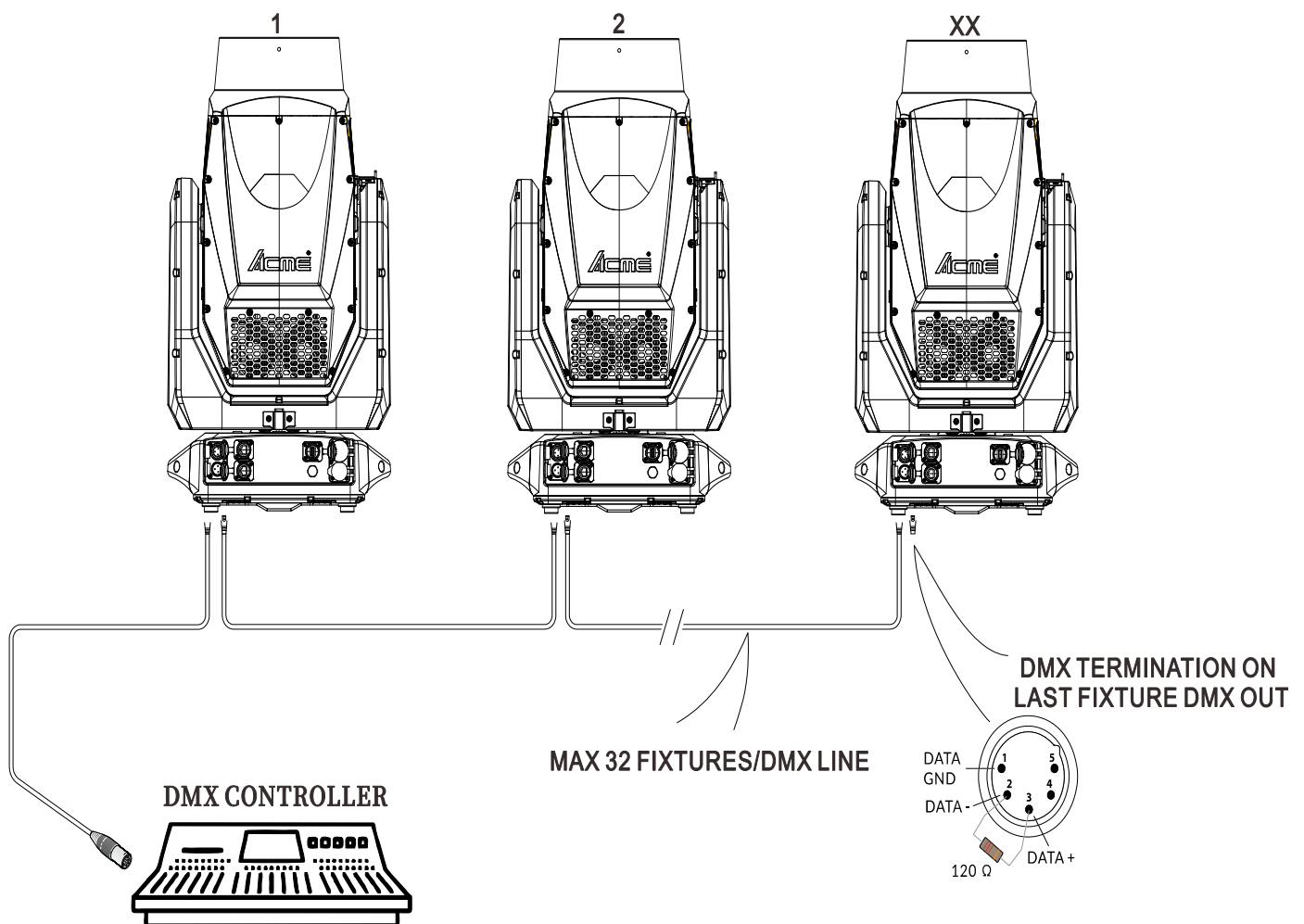

05/ Fixture Installation

The fixture is IP66-rated and designed for both indoor and outdoor events. This means that it is protected from:

- ▶ Dust, to the degree that dust cannot enter the device in sufficient quantities as to interfere with its operation.
- ▶ Water jets from any direction.

DO install and operate by qualified operator. Fixture(s) should be installed in areas outside walking paths, seating areas, or away from areas where unauthorized personnel might reach the fixture by hand. NEVER stand directly below the fixture(s) when rigging, removing or servicing.

Always ensure that the unit is firmly fixed to avoid vibration and slipping off during operation. Ensure that the trussing or area of installation must be able to hold 10 times the weight without any deformation. Always attach a safety cable that can hold at least 12 times the weight of the fixture whenever installing this fixture in a suspended environment to ensure that the fixture will not fall if the clamp fails.

This fixture is fully operational in three different mounting positions: hanging upside-down, mounted sideways on truss, or base positioned on floor. Always use and install a safety cable as a safety measure to prevent accidental damage and/or injury in the event the clamp fails.

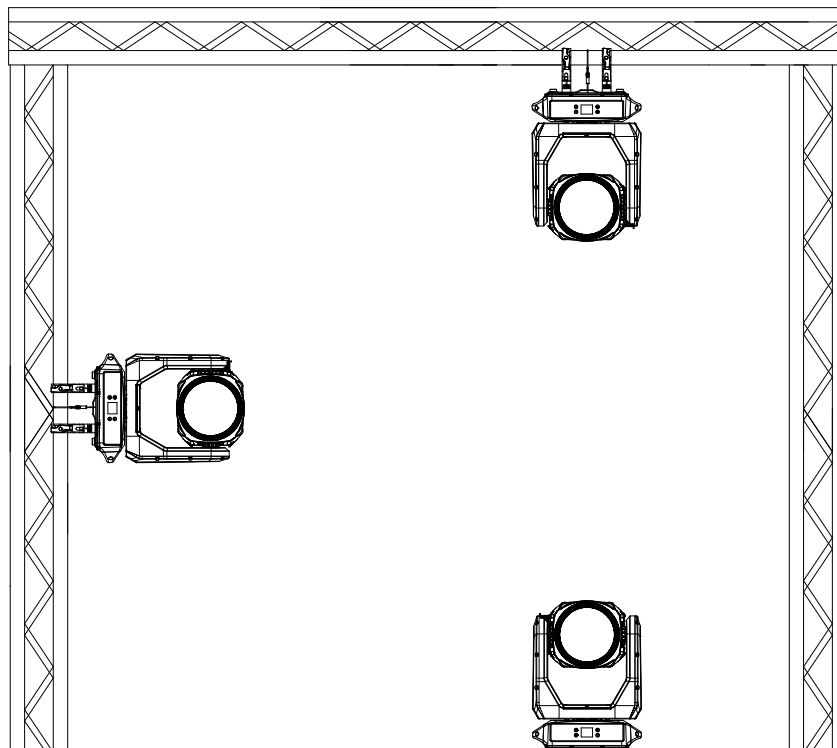



Side Mounting To maintain the IP66 rating integrity of the fixture, all cables must be run towards the ground to prevent water accumulation around the connections.

System menu
LCD display

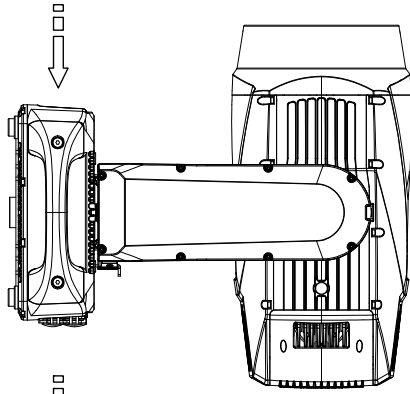

Cables

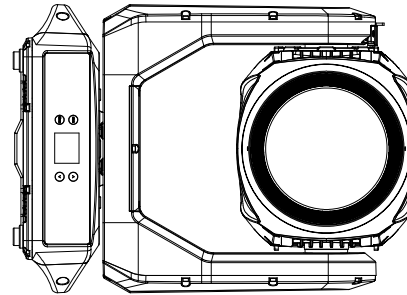

Cables

- Use only IP-rated power cords and connectors suitable for outdoor use.
- Visually check panel connectors on accidental water leaks and dust before connecting related cable connectors.
If some water appears in panel connectors, do not connect cable connectors, especially power!
- Fixtures require regular maintenance.
Carefully check panel connectors for corrosion and scorching, and replace them promptly if damaged.

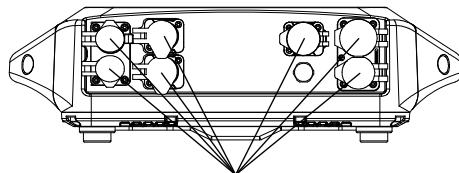

All unused panel connectors have to be sealed by the rubber caps to avoid contact with water, especially seawater.

Steps for installing omega brackets to the fixture:

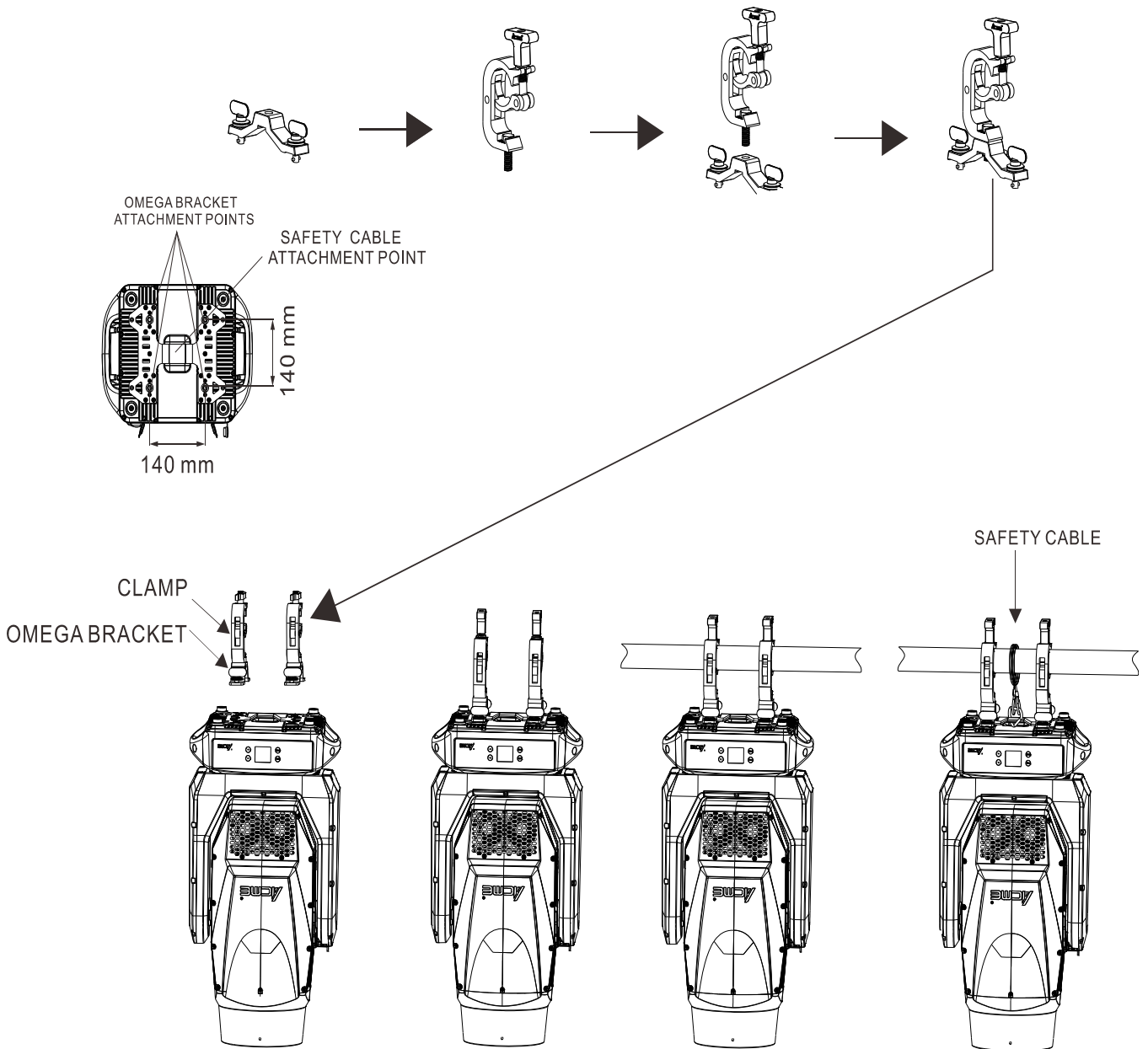

06/ Effect Wheels & Lamp

6.1 Effect Wheels

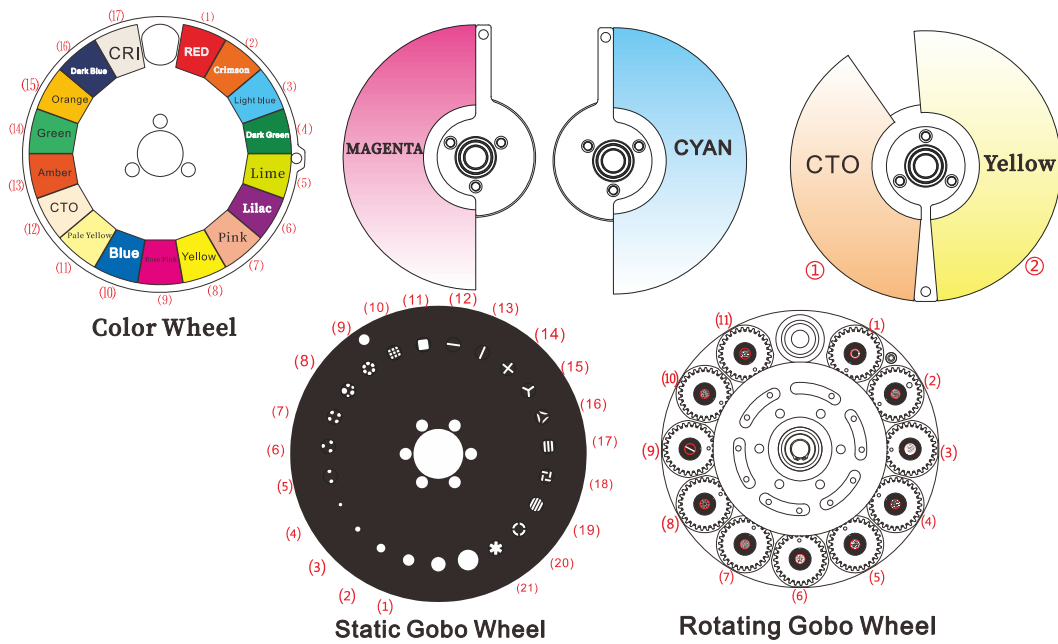

DANGER!

Replace the rotating gobos with the device switched off only.
Unplug from mains before replacing the rotating gobos!

Rotating Gobo Wheel		
Slot	Name	Part Number
Open	Empty	/
1	Grid	3011001788
2	Fine Line Cross	3011001789
3	Geometric Dot Matrix	3011001790
4	Angular Stripes	3011001791
5	Circular Ring	3011001792
6	Hexagonal Lattice	3011001793
7	Linear Wave	3011001794
8	Starburst Mini	3011001795
9	Diamond Weave	3011001796
10	Concentric Circle	3011001797
11	Micro Checkerboard	3011001799

Size of Rotating Gobos				
Slot	Gobo Diameter	Image Area Diameter	Gobo Thickness	Material
1~11	18mm+0/-0.2mm	12mm	1.2mm	Quartz Glass

Follow these precautions when using and handling rotating gobos:

- ▶ Original gobos have a special coating designed specifically to resist to high temperatures. Must use high temperature quartz glass or better glass. Replacement gobos must match the dimensions, construction, materials and quality as the gobos supplied as standard. Using gobos that do not meet this requirement can cause damage that is not covered by the product warranty.
- ▶ Do not use gobos with dark coatings on either side, as these will absorb heat – either directly from the light source or reflected back from other optical components – and will not be durable.
- ▶ Wear clean nitrile cleanroom gloves when handling gobos.
- ▶ Avoid scratching coated and uncoated sides.
- ▶ Correct gobo orientation is critical. Note the position of the reference marks (arrowed) in the gobo drive wheel and gobo holder. Each time you remove a gobo holder from the wheel, turn the drive wheel (twice if necessary) until the marks exactly line up. We recommend that you only remove one gobo holder at a time. Avoid turning the drive wheel while a gobo holder is out of the gobo wheel. This will keep the gobos in their correct orientation, avoiding the need to reprogram cues or adjust gobo positions in the fixture because a gobo orientation has changed during service.

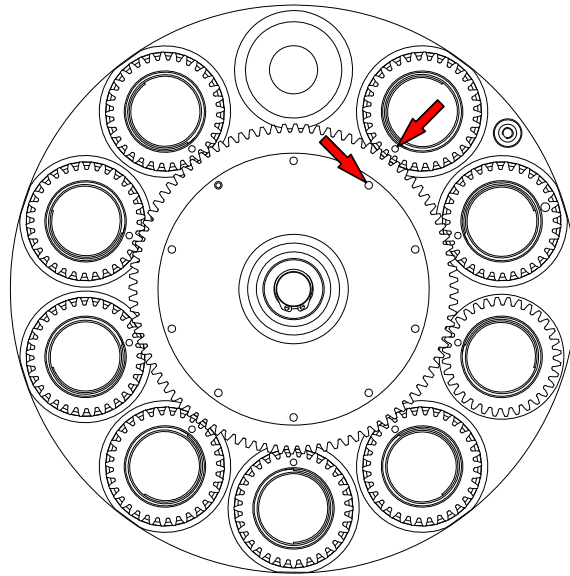

- ▶ Note how the gobo holder tongue engages in a recess in the gobo drive wheel when pulling the gobo holder out of the gobo wheel. You will need to reinstall the gobo holder with the tongue in the same position in the drive wheel.

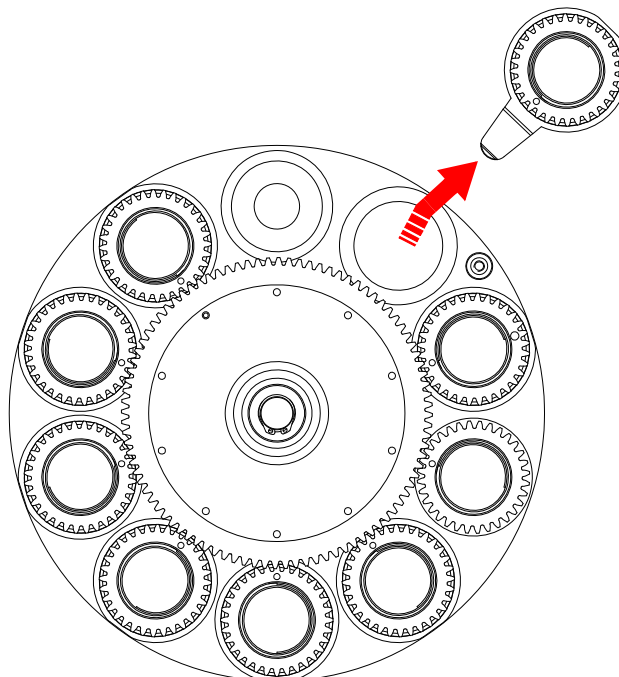

- ▶ Note the position of the alignment marks (arrowed) on gobo holders and gobos. Install gobos with the alignment marks next to each other.

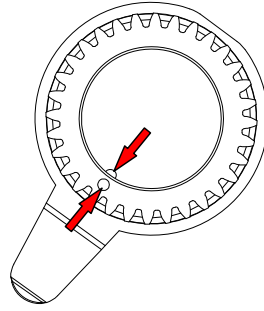

- ▶ With the teeth side of the gobo holder facing upwards, remove the gobo retaining spring carefully with an appropriate tool (e.g. plastic lever) and then remove the original gobo.

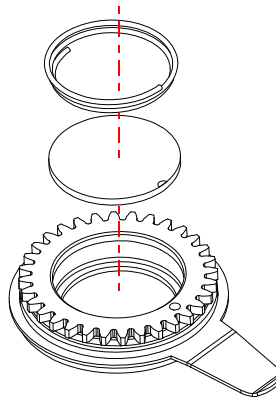

- ▶ Holding the new gobo by its edges, taking care to not leave fingerprints on the gobo, insert it into the gobo holder with the alignment marks on gobo and gobo holder oriented correctly and with the black side facing downwards. Check that the gobo is fully seated in the holder.

Make sure that you install gobos facing in the correct direction - reflective side towards the light source, black side towards the front lens, or they may suffer heat damage.

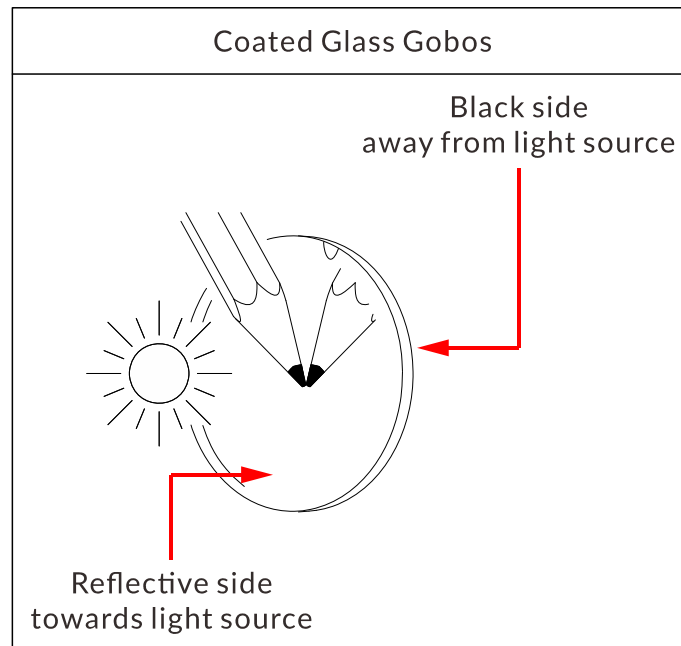

- ▶ Check that the retaining spring is pressed as flat as possible against the gobo and that the gobo is held securely in the gobo holder when reinstalling the retaining spring.
- ▶ Line up the reference marks in the gobo holder and gobo drive wheel and push the tongue correctly into its location in the gobo drive wheel when you install the gobo holder. Check that the gobo holder is held securely in the wheel after you have installed it.

6.2 Light Source

BLL350A-95-R00-000

Because of its high internal pressure, there might be a risk that the discharge lamp would explode during operation. The lamp emits intense UV radiation which is harmful to the eyes and skin. The high luminance of the arc can cause severe damage to the retina if you take a close look at the lamp.

- ▶ To protect the lamp, always turn off the lamp first (via control panel or DMX controller) and let the unit run at least five minutes to cool down before switching off the mains supply. Never handle the lamp or luminary when it is hot.
- ▶ Do not touch the bulb with bare hands. If this happens, clean the lamp with denatured alcohol and wipe it with a lint free cloth before installation.
- ▶ The lamp generates UV radiation. Never operate the lamp without appropriate shielding.

- ▶ When lighting up, the lamp operates at high pressure and there is a slight risk of arc tube rupture. The risk increases with age, temperature and improper handling of the lamp. Do not use the lamp longer than its lifespan.
- ▶ Make sure the lamp is located in the center of the reflector for the best projection.

6.3 Lamp Replacement Warning

- ▶ When the lamp reaches 300 hours before its service time, the display will flash the message “Replace Lamp Soon” for up to 5 minutes. During this period, the fixture will still work normally.
- ▶ When the lamp reaches its service time, the display will flash the message “Replace Lamp Now” for up to 10 minutes. After 10 minutes, the fixture will return to normal operation.
- ▶ When the lamp is continuously used overtime, the display will flash the message “Lamp Timeout Use, Replace Lamp Now” for up to 10 minutes. After 10 minutes, the fixture will return to normal operation.

ATTENTION

Damages caused by the failure to replace the bulb in time are not subject to warranty.

07/ Operation

7.1 Control Menu

- ▶ To access the control menus, press the [MENU] button.
- ▶ Navigate the menu structure, using the [ENTER], [▲ UP] and [▼ DOWN] buttons.
- ▶ To select a menu option or to confirm a selection, press the [ENTER] button.
- ▶ To return to a higher level in the menu structure without making a change, press the [MENU] button, or wait 30 seconds.

The screen locks after 30 seconds of inactivity.
Press and hold the [MENU] button to unlock the screen.

The main functions are shown below:

MAIN MENU	SUBMENU	CHOICES/VALUES		
DMX Settings	DMX Address	1-512	(Default=1)	
	DMX Channel Mode	Mode 1 (28 CH)		
		Mode 2 (31 CH)		
	No DMX Status	Blackout		
		Hold		
		Manual		
	View DMX Value			
	Connect Option	Auto		
		DMX		
		Art-Net		
		sACN		
	Network	IP Address	Default 1:002.xxx.xxx.xxx	
			Default 2:010.xxx.xxx.xxx	
			Manual:xxx.xxx.xxx.xxx	
		Sub-Net Mask	xxx.xxx.xxx.xxx	
	Art-Net Settings	Net	0-127	(Default=0)
		Sub-Net	0-15	(Default=0)
		Universe	0-15	(Default=0)
	sACN Settings	Universe	1-32000	(Default=1)
		Priority	0-200	(Default=100)
Network to DMX	No			
	Yes			
Fixture Settings	Pan Invert	No		

MAIN MENU	SUBMENU	CHOICES/VALUES
		Yes
	Tilt Invert	No
		Yes
	P/T Feedback	No
		Yes
	Pan & Tilt Reset mode	Standard
		Sequence
	Focus Compensate	Disable
		Near (10m)
		Medium (20m)
		Far (30m)
	Dimmer Speed	Fast
		Smooth
	Dimmer Curve	Linear
		Square Law
		Inv SQ Law
		S Curve
	Fan Mode	Standard
		Quiet
	Bright Calibration	50-100 Default=100
	Gobo Short Cut	Enable
		Disable
	Sun Protection Mode	On
		Off
	Sun Protection Mode	Off
		On
	Refresh Rate	900Hz
		1000Hz
		1100Hz
		1200Hz
		1300Hz
		1400Hz
		1500Hz
		2500Hz
		4000Hz
		5000Hz
		6000Hz
		10KHz
		15KHz
		20KHz
		25KHz
	Demist Mode	Off

MAIN MENU	SUBMENU	CHOICES/VALUES				
	Pan Safety Zone	On				
		Off				
	Tilt Safety Zone	On				
		Off				
	Display Settings	Display Invert	No			
			Yes			
Backlight Intensity		1-10				
Temperature Unit		°C				
	°F					
Fixture Test	Auto Test	Single				
		Cycle				
	Manual Test	Mode 1		Mode 2		
		Clear	No/Yes	Clear	No/Yes	
		Pan	0-255			
		Tilt	0-255			
		Cyan	0-255			
		Magenta	0-255			
		Yellow	0-255			
		CTO	0-255			
		Color	0-255			
		Rotate Gobo	0-255			
		Rotate R Gobo	0-255			
		Fixed Gobo	0-255			
		Prism	0-255			
		R-Prism 1	0-255			
		R-Prism 2	0-255			
		Frost	0-255			
		Zoom	0-255			
		Focus	0-255			
Strobe	0-255					
Dimmer	0-255					
Fixture Information	Fixture Use Hour					
	Light Source Use Hour	Total Hour				
		On Hour				
		Hours Reset	Password=050			
	Humidity			Current	Max	
		Base				
Head						

MAIN MENU	SUBMENU	CHOICES/VALUES		
	Temperature		Current	Max
		Light Source		
	Fan State	B_A_FAN1/2		
		A_B_FAN1/2		
		H_C_FAN1/2		
		H_E_FAN1/2/3/4/5		
	Firmware Version			
	RDM UID			
	Error Logs	Fixture Errors		
Reset Error Log		No		
		Yes	Password=050	
Reset Function	Pan/Tilt Reset	No		
		Yes		
	Effect Reset	No		
		Yes		
	All Reset	No		
		Yes		
Special Function	USB Upgrade	No		
		Yes		
	Send Upgrade	No		
		Yes		
	Firmware Restore	No		
		Yes		
	Factory Settings	No		
		Yes		

DMX Settings

Enter the control menu and select **DMX Settings**, press ENTER. Use the UP/DOWN button to select **DMX Address**, **DMX Channel Mode**, **No DMX Status**, **View DMX Value**, **Connect Option**, **Network**, **Art-Net Settings**, **sACN Settings** or **Network to DMX**.

DMX Address

Select **DMX Address**, press ENTER.

Use UP/DOWN button to select an address, confirm your selection with ENTER.

CHANNEL MODE	DMX ADDRESS
Mode 1 (28 CH)	1-485
Mode 2 (31 CH)	1-482

To exit the menu, press MENU, or wait 30 seconds.

DMX Channel Mode

Select **DMX Channel Mode**, press ENTER.

Use UP/DOWN button to select between **Mode 1 (28 CH)** or **Mode 2 (31 CH)**, confirm your selection with ENTER.

To exit the menu, press MENU, or wait 30 seconds.

No DMX Status

Select **No DMX Status**, press ENTER.

Use UP/DOWN button to select one of the following status:

Blackout (Fixture blacks out if DMX signal stops)

Hold (The device continues to operate in the current mode with the last active DMX values until the signal returns)

Manual (The device accepts the DMX value stored in the 'Manual Test' menu)

Confirm your selection with ENTER.

To exit the menu, press MENU, or wait 30 seconds.

View DMX Value

Select **View DMX Value**, press ENTER.

Use UP/DOWN button to select the desired DMX channel, for which the value is to be displayed.

To exit the menu, press MENU, or wait 30 seconds.

Connect Option

Select **Connect Option**, press ENTER.

Use UP/DOWN button to select **Auto**, **DMX**, **Art-Net** or **sACN**, confirm your selection with ENTER.

To exit the menu, press MENU, or wait 30 seconds.

Network

Select **Network**, press ENTER.

Use UP/DOWN button to select **IP Address** or **Subnet Mask**, confirm your selection with ENTER.

To exit the menu, press MENU, or wait 30 seconds.

Art-Net Settings

Select **Art-Net Settings**, press ENTER.

Use UP/DOWN button to select **Net**, **Sub-Net** or **Universe**, confirm your selection with ENTER.

To exit the menu, press MENU, or wait 30 seconds.

sACN Settings

Select **sACN Settings**, press ENTER.

Use UP/DOWN button to select **Universe** or **Priority**, confirm your selection with ENTER.

To exit the menu, press MENU, or wait 30 seconds.

Network to DMX

Select **Network to DMX**, press ENTER.

Use UP/DOWN button to select **No** or **Yes**, confirm your selection with ENTER.

To exit the menu, press MENU, or wait 30 seconds.

Fixture Settings

Enter the control menu and select **Fixture Settings**, press ENTER. Use the UP/DOWN button to select **Pan Invert**, **Tilt Invert**, **P/T Feedback**, **Pan & Tilt Reset mode**, **Focus Compensate**, **Dimmer Speed**, **Dimmer Curve**, **Fan Mode**, **Bright Calibration**, **Gobo Short Cut**, **Sun Protection Mode**, or **LED Refresh Rate**, **Demist Mode**, **Pan Safety Zone** and **Tilt Safety Zone**.

Pan Invert

Select **Pan Invert**, press ENTER.

Use UP/DOWN button to select **No** (pan invert deactivated) or **Yes** (pan invert activated), confirm your selection with ENTER.

To exit the menu, press MENU, or wait 30 seconds.

Tilt Invert

Select **Tilt Invert**, press ENTER.

Use UP/DOWN button to select **No** (tilt invert deactivated) or **Yes** (tilt invert activated), confirm your selection with ENTER.

To exit the menu, press MENU, or wait 30 seconds.

P/T Feedback

Select **P/T Feedback**, press ENTER.

Use UP/DOWN button to select **No** (pan/tilt feedback deactivated) or **Yes** (pan/tilt feedback activated), confirm your selection with ENTER.

To exit the menu, press MENU, or wait 30 seconds.

Pan & Tilt Reset mode

Select **Pan/Tilt Reset**, press ENTER.

Use UP/DOWN button to select **No** or **Yes** (the device will run built-in program to reset pan/tilt to their home positions), confirm your selection with ENTER.

Focus Compensate

Select **Focus Compensate**, press ENTER.

Use UP/DOWN button to select **Disable**, **Near**, **Medium** or **Far**, confirm your selection with ENTER.

To exit the menu, press MENU, or wait 30 seconds. To exit the menu,

Dimmer Speed

Select **Dimmer Speed**, press ENTER.

Use UP/DOWN button to select **Fast** or **Smooth**, confirm your selection with ENTER.

To exit the menu, press MENU, or wait 30 seconds.

Dimmer Curve

Select **Dimmer Curve**, press ENTER.

Use UP/DOWN button to select **Linear**, **Square Law**, **Inv SQ Law** or **S Curve**, confirm your selection with ENTER.

Dimmer Modes

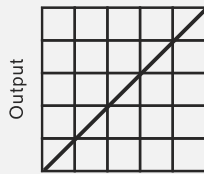

DMX %
Optically Linear

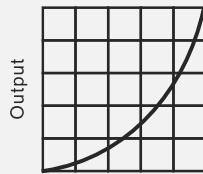

DMX %
Square Law

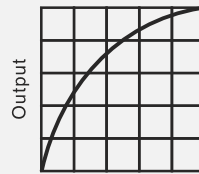

DMX %
Inverse Square Law

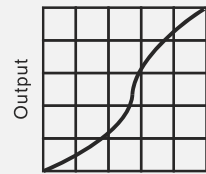

DMX %
S-curve

To exit the menu, press MENU, or wait 30 seconds.

Fan Mode

Select **Fan Mode**, press ENTER.

Use UP/DOWN button to select **Standard**, **Quiet** or **Theatre**, confirm your selection with ENTER.

To exit the menu, press MENU, or wait 30 seconds.

Bright Calibration

Select **Bright Calibration**, press ENTER.

Use UP/DOWN button to select a value between **50** and **100**, confirm your selection with ENTER.

To exit the menu, press MENU, or wait 30 seconds.

Gobo Short Cut

Select **Gobo Short Cut**, press ENTER.

Use UP/DOWN button to select **Enable** or **Disable**, confirm your selection with ENTER.

To exit the menu, press MENU, or wait 30 seconds.

Sun Protection Mode (Set the 'Sun Protection Mode' to 'On' when using the fixture outdoors.)

Select **Sun Protection Mode**, press ENTER.

Use UP/DOWN button to select **Off** (sun protection mode deactivated) or **On** (The fixture will turn off the light source and automatically turn its head to a horizontal position when no signal is detected, preventing damage to optical components or internal parts from prolonged direct sunlight exposure.), confirm your selection with ENTER.

To exit the menu, press MENU, or wait 30 seconds.

LED Refresh Rate

Select **Led Refresh Rate**, press ENTER.

Use UP/DOWN button to select **900Hz, 1000Hz, 1100Hz, 1200Hz, 1300Hz, 1400Hz, 1500Hz, 2500Hz, 4000Hz, 5000Hz, 6000Hz, 10KHz, 15KHz, 20KHz or 25KHz**, confirm your selection with ENTER.

Demist Mode

Select Demist Mode, press ENTER.

Use UP/DOWN button to select **Off** (Demist Mode deactivated) or **On** (Demist Mode activated), confirm your selection with ENTER.

To exit the menu, press MENU, or wait 30 seconds.

Pan Safety Zone

Select Pan Safety Zone, press ENTER.

Use UP/DOWN button to select **Off** (Pan Safety Zone deactivated) or **On** (Pan Safety Zone activated), confirm your selection with ENTER.

To exit the menu, press MENU, or wait 30 seconds.

Tilt Safety Zone

Select Tilt Safety Zone, press ENTER.

Use UP/DOWN button to select **Off** (Tilt Safety Zone deactivated) or **On**(Tilt Safety Zone activated), confirm your selection with ENTER.

To exit the menu, press MENU, or wait 30 seconds.

Display Settings

Enter the control menu and select **Display Settings**, press ENTER. Use the UP/DOWN button to select **Display Invert**, **Backlight Intensity**, **Temperature Unit** or **Language**.

Display Invert

Select **Display Invert**, press ENTER.

Use UP/DOWN button to select **No** (display normal) or **Yes** (display inverted), confirm your selection with ENTER.

To exit the menu, press MENU, or wait 30 seconds.

Backlight Intensity

Select **Backlight Intensity**, press ENTER.

Use UP/DOWN button to select a value between 1 (dark) and 10 (bright), confirm your selection with ENTER.

To exit the menu, press MENU, or wait 30 seconds.

Temperature Unit

Select **Temperature Unit**, press ENTER.

Use UP/DOWN button to select **°C** or **°F**, confirm your selection with ENTER.

To exit the menu, press MENU, or wait 30 seconds.

Fixture Test

Enter the control menu and select **Fixture Test**, press ENTER. Use the UP/DOWN button to select **Auto Test** or **Manual Test**.

Auto Test

Select **Auto Test**, press ENTER.

Use UP/DOWN button to select **Single** (the device immediately performs a single automatic self-test) or **Cycle** (the device immediately performs a cyclic automatic self-test), confirm your selection with ENTER.

To exit the menu, press MENU.

Manual Test

Select **Manual Test**, press ENTER.

Use UP/DOWN button to select the channel for which the manual test is to be performed, confirm your selection with ENTER.

Use UP/DOWN button to select a value, confirm your selection with ENTER.

To exit the menu, press MENU.

(The device returns to its original DMX state after the manual test. The test values are saved automatically when the device is switched off.)

Fixture Information

Enter the control menu and select **Fixture Information**, press ENTER. Use the UP/DOWN button to select **Fixture Use Hour**, **Light source Use Hour**, **Humidity**, **Temperature**, **Fan State**, **Firmware Version**, **RDM UID** or **Error Logs**.

Fixture Use Hour

Select **Fixture Use Hour**, press ENTER.

The operating hours is displayed.

To exit the menu, press MENU, or wait 30 seconds.

Light Source Use Hour

Select **Light Source Use Hour**, press ENTER.

Use UP/DOWN button to set the **Total Hour**, **On Hour** or **Hours Reset** and confirm your selection with ENTER.

To exit the menu, press MENU, or wait 30 seconds.

Humidity

Select **Humidity**, press ENTER.

The device humidity is displayed.

To exit the menu, press MENU, or wait 30 seconds.

Temperature

Select **Temperature** , press ENTER.

Use UP/DOWN button to select °C or °F, confirm your selection with ENTER.

Fan State

Select **Fan State**, press ENTER.

The fan status is displayed.

To exit the menu, press MENU, or wait 30 seconds.

Firmware Version

Select **Firmware Version**, press ENTER.

The firmware version is displayed.

To exit the menu, press MENU, or wait 30 seconds.

RDM UID

Select **RDM UID**, press ENTER.

The RDM UID is displayed.

To exit the menu, press MENU, or wait 30 seconds.

Error Logs

Select **Error Logs**, press ENTER.

Use UP/DOWN button to select **Fixture Errors**, confirm your selection with ENTER.

The error list is displayed.

Use UP/DOWN button to select **Reset Error Log**, confirm your selection with ENTER.

If you wish to reset the relevant error logs, select **Yes**. If you do not wish to reset anything, select **No**. Confirm your selection with ENTER.

If you select **Yes**, use UP/DOWN button to set the password 050, confirm your selection with ENTER. The relevant error logs are reset.

To exit the menu, press MENU, or wait 30 seconds.

Reset Function

Enter the control menu and select **Reset Function**, press ENTER. Use the UP/DOWN button to select **Pan/Tilt Reset**, **Effect Reset** or **All Reset**.

Pan/Tilt Reset

Select **Pan/Tilt Reset**, press ENTER.

Use UP/DOWN button to select **No** or **Yes** (the device will run built-in program to reset pan/tilt to their home positions), confirm your selection with ENTER.

To exit the menu, press MENU, or wait 30 seconds.

Effect Reset

Select **Effect Reset**, press ENTER.

Use UP/DOWN button to select **No** or **Yes** (the device will run built-in program to reset effect to their home positions), confirm your selection with ENTER.

To exit the menu, press MENU, or wait 30 seconds.

All Reset

Select **All Reset**, press ENTER.

Use UP/DOWN button to select **No** or **Yes** (the device will run built-in program to reset all to their home positions), confirm your selection with ENTER.

To exit the menu, press MENU, or wait 30 seconds.

Special Function

Enter the control menu and select **Special Function**, press ENTER. Use the UP/DOWN button to select **USB Upgrade**, **Send Upgrade**, **Firmware Restore** or **Factory Settings**.

USB Upgrade

Select **USB Upgrade**, press ENTER.

The upgrade files are displayed. (See the 'Updating Software' section for details.)

To exit the menu, press MENU, or wait 30 seconds.

Send Upgrade

Select **Send Upgrade**, press ENTER.

If you wish to send upgrade files from this fixture to other fixtures to upgrade their firmware, select **Yes**. Once Yes is selected, the display of this fixture will show “**Sending Packet, Please Wait...**” while the display of next fixtures will show “**Upgrading, Please Wait...**”. A percentage bar will also be displayed. After the update is complete, fixtures will perform a reset (this can take some time).

If you do not wish to send anything, select **No**. Confirm your selection with ENTER.

To exit the menu, press MENU, or wait 30 seconds.

Firmware Restore (After replacing fixture's vice board(s), this function allows you to synchronize the main board's software to all vice board(s), as the software version of the replaced vice board(s) may not consistent with that of the main board.)

Select **Firmware Restore**, press ENTER.

If you wish to restore fixture's firmware, select **Yes**. Once Yes is selected, the display will show “**Upgrading, Please Wait...**”. A percentage bar will also be displayed. After the update is complete, the fixture will perform a reset (this can take some time).

If you do not wish to restore anything, select **No**. Confirm your selection with ENTER.

To exit the menu, press MENU, or wait 30 seconds.

Factory Settings

Select **Factory Settings**, press ENTER.

If you wish to reset the device to the factory settings, select **Yes**. If you do not wish to reset anything, select **No**. Confirm your selection with ENTER.

To exit the menu, press MENU, or wait 30 seconds.

7.2 Updating Software

Only qualified technicians should perform this function! Note all menu settings before updating software! Please note, up to 32 fixtures can be connected together and updated at the same time.

Note: Before using the USB flash drive to update the software, please ensure that the USB flash drive is formatted with the FAT32 file system. Otherwise, you will need to reformat the USB flash drive to FAT32 before transferring the .yfu files, as the fixture will only recognize the files stored on a FAT32 formatted drive.

Format the USB flash drive:

- ▶ Connect the USB flash drive to the computer.
- ▶ Right-click on the USB flash drive disk.
- ▶ Click "Format".
- ▶ Select the "FAT32" file system and click "Start".

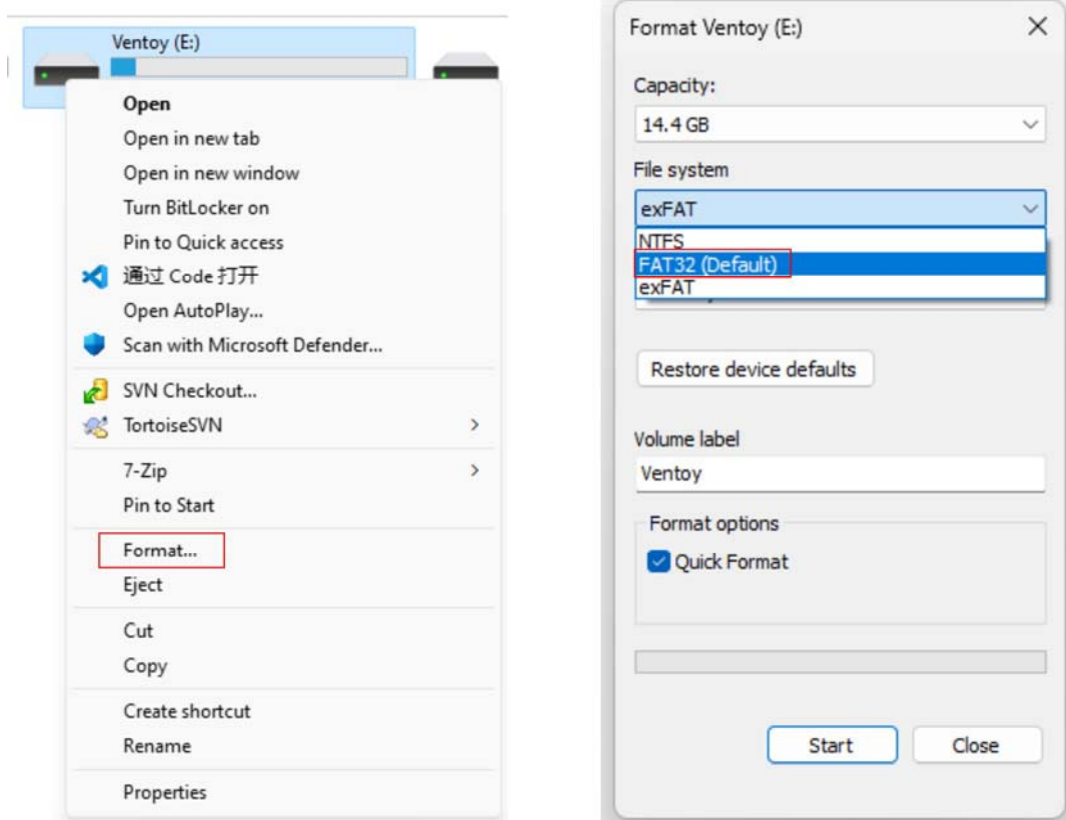

Updating Software:

1. Download the software update files from the ACME website.
2. Copy the software files to a compatible USB flash drive.

Note: To avoid the risk of uploading the wrong file to the fixture, make sure that there are no other files on your flash drive.

3. Disconnect DMX and Ethernet connections and power the fixture on.
4. Insert the USB flash drive into the **FIRMWARE UPGRADE** port located on the rear panel of the fixture.
5. Locate **“Special Function”** within the system menu and press ENTER. Scroll to the **“USB Upgrade”** submenu and press ENTER.
6. Two software files will be displayed as downloaded earlier. Highlight the first file (V00) and press ENTER. Select **“Yes”** to begin the first of two updating processes. Once Yes is selected, the display will show **“Copying Files, Please Wait...”**. After copying is complete, the display will show **“Upgrading, Please Wait...”**. A percentage bar will also be displayed.
7. After the first update is complete, the fixture will perform a reset (this can take some time).
8. Once the reset is complete, scroll to the **“Special Function”** menu again and press ENTER. Scroll to the **“USB Upgrade”** submenu and press ENTER.
9. Highlight the second file (Vxx) this time and press ENTER. Select **“Yes”** to begin the second and final updating process. Once Yes is selected, the display will show **“Copying Files, Please Wait...”** again. After copying is complete, the display will show **“Upgrading, Please Wait...”**. A percentage bar will also be displayed.
10. After the second update is complete, the fixture will perform another reset (this can take some time as well).
11. Remove the USB flash drive.
12. After the reset process is complete, check the new software version to confirm it is updated to the most recent software.

RDM functions: Certain menus of the device and functions can be called up via the RDM protocol.

The parameter IDs are implemented as follows for different commands:

Parameter ID	Command 'Discovery'	Command 'Set'	Command 'Get'
DISC_UNIQUE_BRANCH	√		
DISC_MUTE	√		
DISC_UN_MUTE	√		
SUPPORTED_PARAMETERS			√
PARAMETER_DESCRIPTION			√
DEVICE_INFO			√
DEVICE_MODEL_DESCRIPTION			√
MANUFACTURER_LABEL			√
DEVICE_LABEL		√	√
FACTORY_DEFAULTS		√	√
SOFTWARE_VERSION_LABEL			√
BOOT_SOFTWARE_VERSION_ID			√
BOOT_SOFTWARE_VERSION_LABEL			√
DMX_PERSONALITY		√	√
DMX_PERSONALITY_DESCRIPTION			√
DMX_START_ADDRESS		√	√
SLOT_INFO			√
SLOT_DESCRIPTION			√
SENSOR_DEFINITION			√
SENSOR_VALUE			√
CURVE		√	√
CURVE_DESCRIPTION			√
DEVICE_HOURS			√
LAMP_HOURS			√
PAN_INVERT		√	√
TILT_INVERT		√	√
IDENTIFY_DEVICE		√	√
RESET_DEVICE		√	√

√ -Command implemented for the respective parameter ID

7.3 Home Position Adjustment

- ▶ To access the control menus, press the [MENU] button.
- ▶ To access the offset menus, long-press the [ENTER] button.
- ▶ Navigate the offset menus, using the [ENTER], [▲ UP] and [▼ DOWN] buttons.
- ▶ To select a menu option or to confirm a selection, press the [ENTER] button.
- ▶ To return to a higher level in the menu structure without making a change, press the [MENU] button, or wait 30 seconds.

OFFSET MENU	VALUES
Frequency(1200Hz)	1072~1327
Dimming Start	-500~500
Dimming Offset 1	-500~500
Dimming Offset 2	-500~500
Dimming Offset 3	-500~500
Dimming Offset 4	-500~500
Pan	-128~127
Tilt	-128~127
Cyan	-128~127
Magenta	-128~127
Yellow	-128~127
CTO	-128~127
Color	-128~127
Gobo2	-128~127
R-Gobo2	-128~127
Gobo1	-128~127
Prism1	-128~127
Prism2	-128~127
R-Prism 1	-128~127
Prism3	-128~127
Prism4	-128~127
R-Prism 2	-128~127
Frost	-128~127
Zoom	-128~127
Focus	-128~127

Frequency(Hz)

Select **Frequency(Hz)**, press ENTER.

Use UP/DOWN button to select a value, confirm your selection with ENTER.

To exit the offset menu, press MENU, or wait 30 seconds.

Frequency	VALUES
900Hz	772~1027
1000Hz	872~1127
1100Hz	972~1227
1200Hz	1072~1327
1300Hz	1172~1427
1400Hz	1272~1527
1500Hz	1372~1627
2500Hz	2372~2627
4000Hz	3872~4127
5000Hz	4872~5127
6000Hz	5872~6127
10KHz	9872~10127
15KHz	14872~15127
20KHz	19872~20127
25KHz	24872~25127

Dimming Start

Select **Dimming Start**, press ENTER.

Use UP/DOWN button to select a value between 0 and 9999, confirm your selection with ENTER.

To exit the offset menu, press MENU, or wait 30 seconds.

Dim 1/2/3/4 Offset

Select **Dim 1/2/3/4 Offset**, press ENTER.

Use UP/DOWN button to select a value between -128 and 127, confirm your selection with ENTER.

To exit the offset menu, press MENU, or wait 30 seconds.

Pan

Select **Pan**, press ENTER.

Use UP/DOWN button to select a value between -128 and 127, confirm your selection with ENTER.

To exit the offset menu, press MENU, or wait 30 seconds.

Tilt

Select **Tilt**, press ENTER.

Use UP/DOWN button to select a value between -128 and 127, confirm your selection with ENTER.

To exit the offset menu, press MENU, or wait 30 seconds.

Cyan

Select **Cyan**, press ENTER.

Use UP/DOWN button to select a value between -128 and 127, confirm your selection with ENTER.

To exit the offset menu, press MENU, or wait 30 seconds.

Magenta

Select **Magenta**, press ENTER.

Use UP/DOWN button to select a value between -128 and 127, confirm your selection with ENTER.

To exit the offset menu, press MENU, or wait 30 seconds.

Yellow

Select **Yellow**, press ENTER.

Use UP/DOWN button to select a value between -128 and 127, confirm your selection with ENTER.

To exit the offset menu, press MENU, or wait 30 seconds.

CTO

Select **CTO**, press ENTER.

Use UP/DOWN button to select a value between -128 and 127, confirm your selection with ENTER.

To exit the offset menu, press MENU, or wait 30 seconds.

Color

Select **Color** , press ENTER.

Use UP/DOWN button to select a value between -128 and 127, confirm your selection with ENTER.

To exit the offset menu, press MENU, or wait 30 seconds.

Gobo 2

Select **Gobo 2**, press ENTER.

Use UP/DOWN button to select a value between -128 and 127, confirm your selection with ENTER.

To exit the offset menu, press MENU, or wait 30 seconds.

R-Gobo 2

Select **R-Gobo 2**, press ENTER.

Use UP/DOWN button to select a value between -128 and 127, confirm your selection with ENTER.

To exit the offset menu, press MENU, or wait 30 seconds.

Gobo 1

Select **Gobo 1**, press ENTER.

Use UP/DOWN button to select a value between -128 and 127, confirm your selection with ENTER.

To exit the offset menu, press MENU, or wait 30 seconds.

Prism 1

Select **Prism 1**, press ENTER.

Use UP/DOWN button to select a value between -128 and 127, confirm your selection with ENTER.

To exit the offset menu, press MENU, or wait 30 seconds.

R-Prism 1

Select **R-Prism 1**, press ENTER.

Use UP/DOWN button to select a value between -128 and 127, confirm your selection with ENTER.

To exit the offset menu, press MENU, or wait 30 seconds.

Prism 2

Select **Prism 2**, press ENTER.

Use UP/DOWN button to select a value between -128 and 127, confirm your selection with ENTER.

To exit the offset menu, press MENU, or wait 30 seconds.

R-Prism 2

Select **R-Prism 2**, press ENTER.

Use UP/DOWN button to select a value between -128 and 127, confirm your selection with ENTER.

To exit the offset menu, press MENU, or wait 30 seconds.

Frost

Select **Frost**, press ENTER.

Use UP/DOWN button to select a value between -128 and 127, confirm your selection with ENTER.

To exit the offset menu, press MENU, or wait 30 seconds.

Zoom

Select **Zoom**, press ENTER.

Use UP/DOWN button to select a value between -128 and 127, confirm your selection with ENTER.

To exit the offset menu, press MENU, or wait 30 seconds.

Focus

Select **Focus**, press ENTER.

Use UP/DOWN button to select a value between -128 and 127, confirm your selection with ENTER.

To exit the offset menu, press MENU, or wait 30 seconds.

08/ Configuring the Device for DMX Control

8.1 Address Setting

All fixtures should be given a DMX starting address when operating with a DMX controller, in order to ensure that the correct fixture responds to the correct control signal. Incorrect settings will result in unpredictable responses from the lighting controller.

You can set the same starting address for all fixtures or a group of fixtures, or set different addresses for each individual fixture.

Setting all fixtures to the same DMX address will cause all fixtures to react in the same way. In this case, please note that changing the settings of one channel will affect all the fixtures simultaneously.

If you set each fixture to a different DMX address, each unit will “listen” starting at the channel number you have set, based on the quantity of DMX channels of each fixture. That means changing the settings of one channel will only affect the selected fixture.

For example, if the first fixture is set to 28 ch DMX mode with a start DMX address of 1, the following fixture in the DMX chain should then be set to a DMX address of 29. As the first fixture uses all the first 28 DMX channels, the next available channel is 29 ($28+1=29 \gg 29$).

See the chart below for more details:

Channel Mode	Unit 1 Address	Unit 2 Address	Unit 3 Address	Unit 4 Address	Unit xxx Address
28 channels	1	29	57	85
31 channels	1	32	63	94

8.2 DMX Protocol

CHANNEL		VALUE	FUNCTION
28ch	31ch		
1	1	000-255	PAN 0°→540°
2	2	000-255	PAN FINE
3	3	000-255	TILT 0°→265°
4	4	000-255	TILT FINE
5	5	000-255	PAN/TILT SPEED Fast to Slow
6	6	000-255	CYAN 0%→100%
	7	000-255	CYAN FINE 0%→100%
7	8	000-255	MAGENTA 0%→100%
	9	000-255	MAGENTA FINE 0%→100%
8	10	000-255	YELLOW 0%→100%
	11	000-255	YELLOW FINE 0%→100%
9	12	000-255	CTO 0%→100%
10	13		COLOR WHEEL 1
		000-007	Open
		008-010	Color 1
		011-013	Color 2
		014-016	Color 3
		017-019	Color 4
		020-022	Color 5
		023-025	Color 6
		026-028	Color 7
		029-031	Color 8
		032-034	Color 9
		035-037	Color 10
		038-040	Color 11
		041-043	Color 12
		044-046	Color 13
		047-049	Color 14
050-052	Color 15		
053-055	Color 16		

		056-063	Color 17
		64	Open
		65	Open+ Color1
		66	Color1
		67	Color1+ Color2
		68	Color2
		69	Color2+ Color3
		70	Color3
		71	Color3+ Color4
		72	Color4
		73	Color4+ Color5
		74	Color5
		75	Color5+ Color6
		76	Color6
		77	Color6+ Color7
		78	Color7
		79	Color7+ Color8
		80	Color8
		81	Color8+ Color9
		82	Color9
		83	Color9+ Color10
		84	Color10
		85	Color10+ Color11
		86	Color11
		87	Color11+ Color12
		88	Color12
		89	Color12+ Color13
		90	Color13
		91	Color13+ Color14
		92	Color14
		93	Color14+ Color15
		94	Color15
		95	Color15+ Color16
		96	Color16
		97	Color16+ Color17
		98	Color17
		99	Color17+ Open
		100-127	Open
		128-189	Counter-Clockwise rotation, fast to slow
		190-193	Stop
		194-255	Clockwise rotation, slow to fast
11	14		GOBO(11+1)
		000-007	Open
		008-012	GOBO1
		013-017	GOBO2
		018-022	GOBO3
		023-027	GOBO4

		028-032 033-037 038-042 043-047 048-052 053-057 058-063 064-068 069-073 074-078 079-083 084-088 089-093 094-098 099-103 104-108 109-113 114-127 128-189 190-193 194-255	GOBO5 GOBO6 GOBO7 GOBO8 GOBO9 GOBO10 GOBO11 GOBO1 Shaking Slow->Fast GOBO2 Shaking Slow->Fast GOBO3 Shaking Slow->Fast GOBO4 Shaking Slow->Fast GOBO5 Shaking Slow->Fast GOBO6 Shaking Slow->Fast GOBO7 Shaking Slow->Fast GOBO8 Shaking Slow->Fast GOBO9 Shaking Slow->Fast GOBO10 Shaking Slow->Fast GOBO11 Shaking Slow->Fast Counter-Clockwise rotation, fast to slow Stop Clockwise rotation, slow to fast
12	15	000-127 128-189 190-193 194-255	R-GOBO 0%→100% Counter-Clockwise Rotation slow to fast Stop Clockwise Rotation fast to slow
13	16	000-255	R-GOBO FINE 0%→100%
14	17	000-007 008-009 010-011 012-013 014-015 016-017 018-019 020-021 022-023 024-025 026-027 028-029 030-031 032-033 034-035 036-037 038-039 040-041	FIX-GOBO(21+1) Open GOBO1 GOBO2 GOBO3 GOBO4 GOBO5 GOBO6 GOBO7 GOBO8 GOBO9 GOBO10 GOBO11 GOBO12 GOBO13 GOBO14 GOBO15 GOBO16 GOBO17

		042-043 044-045 046-047 048-063 064-066 067-069 070-072 073-075 076-078 079-081 082-084 085-087 088-090 091-093 094-096 097-099 100-102 103-105 106-108 109-111 112-114 115-117 118-120 121-123 124-127 128-189 190-193 194-255	GOBO18 GOBO19 GOBO20 GOBO21 GOBO1 Shaking Slow->Fast GOBO2 Shaking Slow->Fast GOBO3 Shaking Slow->Fast GOBO4 Shaking Slow->Fast GOBO5 Shaking Slow->Fast GOBO6 Shaking Slow->Fast GOBO7 Shaking Slow->Fast GOBO8 Shaking Slow->Fast GOBO9 Shaking Slow->Fast GOBO10 Shaking Slow->Fast GOBO11 Shaking Slow->Fast GOBO12 Shaking Slow->Fast GOBO13 Shaking Slow->Fast GOBO14 Shaking Slow->Fast GOBO15 Shaking Slow->Fast GOBO16 Shaking Slow->Fast GOBO17 Shaking Slow->Fast GOBO18 Shaking Slow->Fast GOBO19 Shaking Slow->Fast GOBO20 Shaking Slow->Fast GOBO21 Shaking Slow->Fast Counter-Clockwise rotation, fast to slow Stop Clockwise rotation, slow to fast
15	18	000-007 008-031 032-063 064-095 096-127 128-159 160-191 192-223 224-255	PRISM Close Prism1 Prism2 Prism3 Prism4 Prism1 + Prism3 Prism1 + Prism4 Prism2 + Prism3 Prism2 + Prism4
16	19	000-127 128-189 190-193 194-255	R-PRISM 1 Index 0°~360° Clockwise Rotation, Fast to Slow Stop Counter-Clockwise Rotation, Slow to Fast
17	20	000-127 128-189 190-193	R-Prism 2 Index 0°~360° Clockwise Rotation, Fast to Slow Stop

		194-255	Counter-Clockwise Rotation, Slow to Fast
18	21	000-007 008-255	FROST Close Open
19	22	000-255	ZOOM Wide→Narrow
20	23	000-255	ZOOM FINE Wide→Narrow
21	24	000-255	FOCUS 0%→100%
22	25	000-255	FOCUS FINE
23	26	000-007 008-015 016-131 132-139 140-181 182-189 190-231 232-239 240-247 248-255	STROBE Close Open Strobe Slow-→Fast Open Fast Open Slow Close Open Fast Close Slow Open Open Random Strobe Slow-→Fast Open
24	27	000-255	DIMMER 0%→100%
25	28	000-255	DIMMER FINE
26	29	000-007 008-048 049-089 090-130 131-171 172-212 213-255	Pan Safety Zone No Function Mode Close Mode Open Set Start Pos Save Start Pos Set End Pos Save End Pos
27	30	000-007 008-048 049-089 090-130 131-171 172-212 213-255	Tilt Safety Zone No Function Mode Close Mode Open Set Start Pos Save Start Pos Set End Pos Save End Pos
28	31	000-009	SPECIAL FUNCTION (To activate following functions, stop in DMX value for at least 3 seconds.) No Function

010-011	Demist Mode: On
012-013	Demist Mode: Off
014-029	No Function
030-039	Dimmer Curve Linear
040-049	Dimmer Curve Square Law
050-059	Dimmer Curve Inv Square Law
060-069	Dimmer Curve S
070-079	Fan Mode Standard
080-089	Fan Mode Quiet
090-099	No Function
100-109	LED Frequency Setting Enable
110-119	LED Frequency Setting Disable
120-122	No Function
123	900HZ
124	1000HZ
125	1100HZ
126	1200HZ
127	1300HZ
128	1400HZ
129	1500HZ
130	2500HZ
131	4000HZ
132	5000HZ
133	6000HZ
134	10000HZ
135	15000HZ
136	20000HZ
137	25000HZ
138-139	No Function
140-149	Pan/tilt Reset
150-159	Effect Reset
160-171	No Function
172-173	Focus Compensate Disable
174-175	Focus Compensate Near (10m)
176-177	Focus Compensate Medium (20m)
178-179	Focus Compensate Far (30m)
180-181	Sun Protection Mode: On
182-183	Sun Protection Mode: Off
184-189	No Function
190-199	No Function
200-209	Reset all
210-219	Dimmer Speed Fast
220-229	Dimmer Speed Smooth
230-231	GOBO Short Cut Enable
232-233	GOBO Short Cut Disable
234-255	No Function

09/ Error Information

Error codes are shown continuously in the display when the fixture fails and they will not disappear until the fixture is repaired.

CPU-B/C/D/E/F/G Error

Check whether the 485 (DATA) leads on the PCB board are installed in place or disconnected.

Check whether the related 485 (DATA) signal circuit on the PCB board is damaged.

Laser Timeout use

Laser Too Hot Off

When the fixture temperature reaches 86°C, it will automatically turn off to protect the fixture.

Pan Reset Error

Check whether the position of the pan where the magnet is installed falls off or is damaged.

Check whether there are obstacles in the pan operating range.

Check whether the Hall element on the pan is damaged.

Check whether the lead connecting the Hall element on the pan and the PCB board is in poor contact or disconnected.

Check whether the motor on the pan is damaged.

Check whether the related circuit of the motor drive board on the pan is damaged.

Pan Encode Error

Check whether the encoder on the pan is damaged.

Check whether the lead connecting the encoder on the pan and the PCB board is in poor contact or disconnected.

Pan Encode No Find

Check whether the lead connecting the encoder on the pan and the PCB board is in poor contact or disconnected.

Pan Encode Disable

Check whether the encoder on the pan is damaged.

Tilt Reset Error

Check whether the position of the tilt where the magnet is installed falls off or is damaged.

Check whether there are obstacles in the tilt operating range.

Check whether the Hall element on the tilt is damaged.

Check whether the lead connecting the Hall element on the tilt and the PCB board is in poor contact or disconnected.

Check whether the motor on the tilt is damaged.

Check whether the related circuit of the motor drive board on the tilt is damaged.

Tilt Encode Error

Check whether the encoder on the tilt is damaged.

Check whether the lead connecting the encoder on the tilt and the PCB board is in poor contact or disconnected.

Tilt Encode No Find

Check whether the lead connecting the encoder on the tilt and the PCB board is in poor contact or disconnected.

Tilt Encode Disable

Check whether the encoder on the tilt is damaged.

Cyan Reset Error

Check whether the position of the cyan color wheel where the magnet is installed falls off or is damaged.

Check whether there are obstacles in the cyan color wheel operating range.

Check whether the Hall element on the cyan color wheel is damaged.

Check whether the lead connecting the Hall element on the cyan color wheel and the PCB board is in poor contact or disconnected.

Check whether the motor on the cyan color wheel is damaged.

Check whether the related circuit of the motor drive board on the cyan color wheel is damage.

Magenta Reset Error

Check whether the position of the magenta color wheel where the magnet is installed falls off or is damaged.

Check whether there are obstacles in the magenta color wheel operating range.

Check whether the Hall element on the magenta color wheel is damaged.

Check whether the lead connecting the Hall element on the magenta color wheel and the PCB board is in poor contact or disconnected.

Check whether the motor on the magenta color wheel is damaged.

Check whether the related circuit of the motor drive board on the magenta color wheel is damage.

Yellow Reset Error

Check whether the position of the yellow color wheel where the magnet is installed falls off or is damaged.

Check whether there are obstacles in the yellow color wheel operating range.

Check whether the Hall element on the yellow color wheel is damaged.

Check whether the lead connecting the Hall element on the yellow color wheel and the PCB board is in poor contact or disconnected.

Check whether the motor on the yellow color wheel is damaged.

Check whether the related circuit of the motor drive board on the yellow color wheel is damage.

Color 1 Reset Error

Check whether the position of the color wheel where the magnet is installed falls off or is damaged.

Check whether there are obstacles in the color wheel operating range.

Check whether the Hall element on the color wheel is damaged.

Check whether the lead connecting the Hall element on the color wheel and the PCB board is in poor contact or disconnected.

Check whether the motor on the color wheel is damaged.

Check whether the related circuit of the motor drive board on the color wheel is damage.

Rotating Gobo Error

Check whether the position of the rotating gobo wheel where the magnet is installed falls off or is damaged.

Check whether there are obstacles in the rotating gobo wheel operating range.

Check whether the Hall element on the rotating gobo wheel is damaged.

Check whether the lead connecting the Hall element on the rotating gobo wheel and the PCB board is in poor contact or disconnected.

Check whether the motor on the rotating gobo wheel is damaged.

Check whether the related circuit of the motor drive board on the rotating gobo wheel is damage.

R-Gobo Reset Error

Check whether the position of the rotating gobo wheel where the magnet is installed falls off or is damaged.

Check whether there are obstacles in the rotating gobo wheel operating range.

Check whether the Hall element on the rotating gobo wheel is damaged.

Check whether the lead connecting the Hall element on the rotating gobo wheel and the PCB board is in poor contact or disconnected.

Check whether the motor on the rotating gobo wheel is damaged.

Check whether the related circuit of the motor drive board on the rotating gobo wheel is damage.

Fixed Gobo Error

Check whether the position of the fixed gobo wheel where the magnet is installed falls off or is damaged.

Check whether there are obstacles in the fixed gobo wheel operating range.

Check whether the Hall element on the fixed gobo wheel is damaged.

Check whether the lead connecting the Hall element on the fixed gobo wheel and the PCB board is in poor contact or disconnected.

Check whether the motor on the fixed gobo wheel is damaged.

Check whether the related circuit of the motor drive board on the fixed gobo wheel is damage.

Prism 1/2 Reset Error

Check whether the position of the prism 1/2 where the magnet is installed falls off or is damaged.

Check whether there are obstacles in the prism 1/2 operating range.

Check whether the Hall element on the prism 1/2 is damaged.

Check whether the lead connecting the Hall element on the prism 1/2 and the PCB board is in poor contact or disconnected.

Check whether the motor on the prism 1/2 is damaged.

Check whether the related circuit of the motor drive board on the prism 1/2 is damage.

R-Prism 1/2 Reset Error

Check whether the position of the prism 1/2 where the magnet is installed falls off or is damaged.

Check whether there are obstacles in the prism 1/2 operating range.

Check whether the Hall element on the prism 1/2 is damaged.

Check whether the lead connecting the Hall element on the prism 1/2 and the PCB board is in poor contact or disconnected.

Check whether the motor on the prism 1/2 is damaged.

Check whether the related circuit of the motor drive board on the prism 1/2 is damage.

Zoom Reset Error

Check whether the position of the zoom where the magnet is installed falls off or is damaged.

Check whether there are obstacles in the zoom operating range.

Check whether the Hall element on the zoom is damaged.

Check whether the lead connecting the Hall element on the zoom and the PCB board is in poor contact or disconnected.

Check whether the motor on the zoom is damaged.

Check whether the related circuit of the motor drive board on the zoom is damage.

CPUA G Sensor Err.

Please contact an authorized after-sales service center for repairs.

Focus Reset Error

Check whether the position of the focus where the magnet is installed falls off or is damaged.

Check whether there are obstacles in the focus operating range.

Check whether the Hall element on the focus is damaged.

Check whether the lead connecting the Hall element on the focus and the PCB board is in poor contact or disconnected.

Check whether the motor on the focus is damaged.

Check whether the related circuit of the motor drive board on the focus is damage.

Base Fan 1/2 Start Error

Check whether the fan is not running.

Check whether the fan leads are installed in place or disconnected.

Check whether the fan is damaged.

Check whether there are obstacles in the fan operating range.

Arm Fan Start Error

Check whether the fan is not running.

Check whether the fan leads are installed in place or disconnected.

Check whether the fan is damaged.

Check whether there are obstacles in the fan operating range.

Head Fan 1/2/3/4/5 Start Error

Check whether the fan is not running.

Check whether the fan leads are installed in place or disconnected.

Check whether the fan is damaged.

Check whether there are obstacles in the fan operating range.

Base Humidity Error

Check whether the humidity sensor is faulty.

Check whether the lead connecting the humidity sensor is installed in place or disconnected.

Head Humidity Error

Check whether the humidity sensor is faulty.

Check whether the lead connecting the humidity sensor is installed in place or disconnected.

Base Humi. Too High

Disassemble the housing of the fixture to dehumidify.

Head Humi. Too High

Disassemble the housing of the fixture to dehumidify.

Memory Error

When the memory IC keeps reporting errors, please replace the motherboard.

Network Error

Check whether the net model is installed in place.

Check whether the net model is damaged.

Check whether the network is normal.

External Flash Error

Check whether the external flash storage device is properly inserted and secured.

Check whether the flash storage device is damaged or its file format is incompatible.

Check whether the lead connecting the external flash interface and the main PCB board is in poor contact or disconnected.

Position of cooling fans:

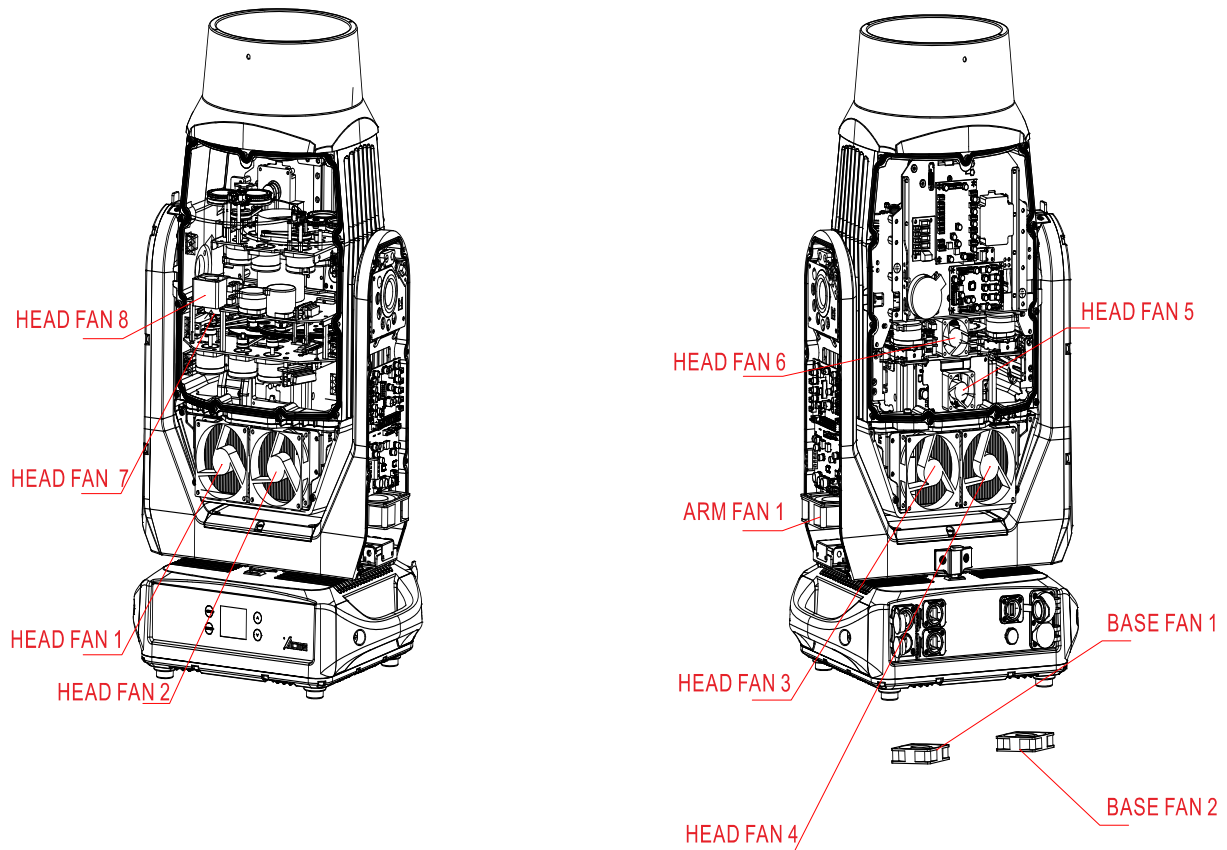

Cooling Fans	Part Number	V	W	Position
Base Fan 1	3014001422	DC 24V	3.6W	A-FAN1
Base Fan 2	3014001251	DC 24V	3.6W	A-FAN2
Arm Fan	3014001256	DC 24V	4.8W	B-FAN1
Head Fan 1	3014003027	DC 24V	6.7W	E-FAN1
Head Fan 2				E-FAN2
Head Fan 3				E-FAN3
Head Fan 4	3014003027	DC 24V	6.7W	E-FAN4
Head Fan 5	3014001401	DC 24V	1.7W	E-FAN5
Head Fan 6	3014001428	DC 24V	7.2W	B-FAN2
Head Fan 7	3014001300	DC 24V	2.9W	C-FAN1
Head Fan 8	3014001428	DC 24V	7.2W	C-FAN2

10/ Troubleshooting

Problem	Potential cause(s)	Remedies
Fixture does not respond or appears to be off.	No power to the fixture.	Confirm that the power is switched on and cables are plugged in.
	No output from PSU.	Replace the PSU.
Fixture suddenly turned off.	Power was turned off.	Check the power supply, switches and breakers.
Light output cuts out intermittently.	Fixture is too hot.	Check fixture's stored error messages for more information. Allow fixture to cool. Clean fixture. Reduce ambient temperature.
Fixture suddenly stopped responding.	DMX cables were disconnected.	Inspect DMX cables.
Fixture operates irregularly / abnormal.	Incorrect DMX address or DMX mode.	Inspect and enter the correct DMX address or mode.
	DMX link is not terminated.	Install a XLR 120ohm DMX termination at the end of the DMX link.
	Bad data link.	Replace or repair defective cables and/or connections.
	One of the fixtures is defective and is disturbing data transmission on the link.	Track and isolate the corrupted fixture. Have the fixture serviced by a qualified technician.
Pan / tilt is skipping / shuddering	Pan/ tilt locks are not released.	Release the pan / tilt locks.
	Obstacles are within the required pan / tilt clearance.	Inspect and remove any obstacles constraining free operation of the pan / tilt.
	The Hall element is damaged.	Replace the Hall element.
	The magnetic steel fell out.	Replace the magnetic steel.

11/ Fixture Cleaning

Regular cleaning is very important for fixture life and performance. Buildup of dust, dirt, smoke particles, fog fluid residues, etc. degrades the fixture's light output and cooling ability. Cleaning schedules for lighting fixtures vary greatly depending on the operating environment. It is therefore impossible to specify precise cleaning intervals for the fixture. Environmental factors that may result in a need for frequent cleaning include:

- ▶ Use of smoke or fog machines.
- ▶ High airflow rates (near air conditioning vents, for example).
- ▶ Airborne dust (from stage effects, building structures and fittings or the natural environment at outdoor events, for example).

If one or more of these factors is present, inspect fixtures within their first few hours of operation to see whether cleaning is necessary. Check again at frequent intervals. This procedure will allow you to assess cleaning requirements in your particular situation.

Follow these precautions when cleaning the fixture:

- ▶ Work in a clean, dry, well-lit area.
- ▶ Use gentle pressure only. A soft lint-free cloth dampened with a solution of water and a mild detergent is recommended, under no circumstances should alcohol, solvents or abrasives be used! Use care when cleaning optical components: surfaces are fragile and easily scratched.

12/ Approvals and Certifications

This product has been tested and found to comply with the following standards:

- 2014/30/EU - Electromagnetic Compatibility (EMC)
- 2014/35/EU - Low Voltage Directive (LVD)



The information in this document is subject to change without notice.

For the latest information, visit www.acmelighting.com.



www.acmelighting.com